

Electromagnetic Single Disc Clutches E210 and E220

Service Manual

P-2033-WE
SM307-gb-11/04



 **Warner**[®]
Electric

An Altra Industrial Motion Company

We: **WARNER ELECTRIC EUROPE**, 7, rue Champfluer, B.P. 20095, F-49182 St Barthélemy d'Anjou Cedex declare that the clutches made in our factories from St Barthélemy d'Anjou,

and hereafter designated: **E210 and E220**

are exclusively designed for incorporation into a machine and to be assembled with other equipments to create a machine. The operation of the product is submitted to the conformity of the complete equipment, following the provisions of the machinery directive 98/37/EC and if electric to the EMC directive 89/336/EEC.

The conformity of the electric units to the Low Voltage directive 72/23 (modified) is supported by the full respect of the following standards: NFC 79300 and VDE 05808/8.65.

Drawn up in St Barthélemy d'Anjou, july 2002

E. PRAT, General Managing Director

CONTENTS



| | | | | | |
|-----|-------------------------------------|---|-------|----------------------------|---|
| 1 | Technical specifications | 2 | 3.3.1 | Installing VAR00 and VAR02 | 3 |
| 2 | Precautions and restrictions on use | 2 | 3.3.2 | Installing VAR05 | 4 |
| 2.1 | Restrictions on use | 2 | 4 | Maintenance | 4 |
| 2.2 | Precautions and safety measures | 2 | 4.1 | Maintenance | 4 |
| 3 | Installation | 3 | 4.2 | Spare parts | 4 |
| 3.1 | Transport - storage | 3 | 5 | Electrical connection | 5 |
| 3.2 | Handling | 3 | 5.1 | Important recommendations | 5 |
| 3.3 | Installing | 3 | 5.2 | Power supply | 5 |
| | | | 6 | Appendix | 6 |

1 Technical specifications

| Size | | 200 | 400 | 800 | 1600 | 3200 | 6400 | 12800 |
|-----------------------------|--------|-----------|----------|----------|----------|----------|----------|----------|
| N max. (VAR00) | tr/min | 2600 | 2000 | 1700 | 1500 | 1500 | - | - |
| N max. (VAR02) | tr/min | - | 3000 | 2500 | 2200 | 1800 | 1500 | 1500 |
| Travel P | mm | 0.5 ±0.1 | 0.5 ±0.1 | 0.6 ±0.1 | 0.8 ±0.1 | 0.8 ±0.1 | 1 ±0.1 | 1 ±0.1 |
| Max. travel | mm | 1 | 1.2 | 1.4 | 1.7 | 1.8 | 2.2 | 2.8 |
| Coupling | | 55 | 65 | 75 | 90 | 100 | 125 | 180 |
| Dimension E VAR05 | mm | 30+2.20/0 | 35+2.6/0 | 40+3/0 | 45+3.6/0 | 50+3.6/0 | 60+4.6/0 | 85+6.4/0 |
| Flange-screws (528) (VAR05) | | M8 x 20 | M8 x 20 | M10 x 25 | M12 x 25 | M16 x 25 | M16 x 40 | M20 x 40 |
| Tightening torque | Nm | 22 ±2 | 22 ±2 | 44 ±4 | 76 ±8 | 189 ±18 | 189 ±18 | 370 ±37 |
| Weight (VAR00, 02) | kg | 20 | 25,5 | 35,2 | 61 | 122 | 220 | 380 |
| Weight (VAR05) | kg | 27,4 | 31,5 | 50,5 | 85,5 | 158 | 298 | 597 |

Table 1

NB : data for catalogue equipment

2 Precautions and restrictions on use

2.1 Restrictions on use

 This equipment is designed for dry running. Any oily material alters performance.

 Exceeding the maximum speed of rotation stated in the catalogue invalidates the warranty.

 This equipment is designed for a maximum ambient temperature of 40° (155°C casing class).

 E210 and E220 clutches are designed to operate with centreline horizontal. Vertical fitting is possible only for VAR00.

2.2 Precautions in use and safety measures

 During maintenance, ensure that the machine's moving parts are stationary and that there is no risk of accidental start-up. All intervention have to be made by qualified personnel, owning this manual.

 Any modification made to the brake without the express authorization of a representative of Warner Electric, in the same way than any use out of the contractual specifications accepted by "Warner Electric", will result in the warranty being invalidated and Warner Electric will no longer be liable in any way with regard to conformity.



Symbol designating an action that might damage the brake



Symbol designating an action that might be dangerous to human safety



Symbol designating an electrical action that might be dangerous to human safety

3 Installation

3.1 Transport / storage

Our clutches and brakes are supplied in packaging guaranteeing a preservation period of 6 months with land or air transport, or after transport by ship to neighbouring continents (without crossing the tropics).

3.2 Handling



Avoid any impacts on the equipment so as not to alter their performance.



Never carry the equipment by the electrical supply cable.

3.3 Installing

E210 clutches are supplied reamed to tolerance H7 and splined to tolerance P9 to NF E22175/DIN6885/ISO R773/BS 4235.

E220 clutches are supplied hubs reamed to tolerance H7 and splined to tolerance P9, and armatures assembled reamed to tolerance H8.

We recommend a tolerance H6 for the shaft and F7 the centring of the assembled armature.



Important: Do not forget to stop the inductor (101) rotating by means of a fixed part shaped in the slot.

Check the play between the inductor and this part (see fig. 1): 0,5 minimum in rotation - 1 mm at base of slot.

The part should not cause any strain on the bearings. In case of vibrations, it is strongly recommended to insert a damping elastic slot between the anti-rotation device and the antirotation slot and to fix the coil's cable the nearest of it to avoid whipping.

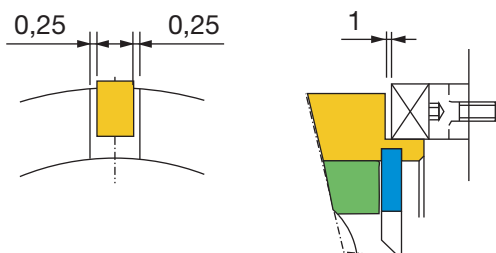

In the case where two co-axial shafts are fitted, the recommended set over is 0,05 mm maximum. The angular misalignment should not be greater than 0,1 mm over a length of 100 mm. If this is the case, use a VAR05 (flexible coupling).



Never dissociate the assembled moving armature (331) (specially factory assembled).



Never pull or hit the assembled moving armature (331), which risks permanently deforming the elastic arms.

3.3.1 Installing VAR00 and VAR02

After adjusting the drive keyway, fit the assembled inductor onto the shaft and clamp it axially.

VAR00:

After adjusting the drive keyway, fit the assembled moving armature (331) on the shaft and clamp it axially on the shaft.

VAR02:

Fit the assembled moving armature (331) onto its support housing and clamp it axially.

It is essential when assembling the 2 parts to respect the travel P (measured in disengaged position) (see appendix 1). To ensure axial wedging, provide for this purpose adjustment spacers in the adaptation. Also check, in the disengaged position, the free rotation, without contact, of the moving armature assembly (331).

NB: In operation, the adjusted travel at start-up can reduce, the moving armature not returning to its initial position. It is not necessary to make a further adjustment unless there is rubbing, in the disengaged position, between the friction surfaces.

3.3.2 Installing VAR05

- After adjusting the drive keyway, fit the assembled inductor on the shaft, then the adjustment spacer, followed by the assembled bearing casing, lastly clamp the whole axially on the shaft.



Caution: The coupling flange (528) is not factory fixed.

- After clamping the device axially on the shaft, assemble the coupling flange (528) with the bolts provided, tightened to torque (see Table 1) and locked with a Loctite 243 type or equivalent product

NB : VAR05 is supplied with a pre-set airgap, however after fitting, check the travel (measured in disengaged position).

- Also check in disengaged position, that the assembled moving armature (331) rotates without contact
- Fit the coupling hub (507) onto the 2nd shaft
- Put the spider (730) inside the coupling flange (528)
- Assemble the moving part with the receiving part by meshing the coupling hub teeth into the hollows of the teeth of the spider (730)



It is essential during fitting to respect dimension E (fitting the flexible coupling) (see tabel 1 and Appendix).

4 Maintenance

4.1 Maintenance

E210 and E220 VAR00:

Bearings are greased on assembly with ELF ROLEXA 2. After about 5000 h running it is necessary to check the bearings and change all grease.

Changing the grease:

Remove the circlips (947), then the inductor with its bearings. Remove the circlips (946), then the bearings (803). Clean the bearings, then grease them again (see table 3 for types of grease to use). Put a quantity of grease equivalent to one third of the volume enclosed between the outer race and inner race.



Caution: Excess grease causes bearings to overheat.

Reassemble the equipment following the procedure in reverse order.

E210 and E220 VAR02 :

Bearings are greased on assembly with ELF ROLEXA 2, but they should be greased at regular intervals, depending on use. Tables 2 and 3 below give the intervals and average quantities of grease and a non exhaustive list of suitable greases for normal applications.

| Size | 400 | 800 | 1600 |
|------------------------|-----------|-------|-------|
| Greasing interval | 1 year or | | |
| | 3000h | 3000h | 3000h |
| Quantity of grease (g) | 12 | 15 | 30 |

| Size | 3200 | 6400 | 12800 |
|------------------------|-----------|-------|-------|
| Greasing interval | 1 year or | | |
| | 2500h | 1200h | 1000h |
| Quantity of grease (g) | 45 | 60 | 85 |

Table 2

| Manufacturer | Grease designation |
|--------------|--------------------|
| ELF | ROLEXA 2 |
| TOTAL | MULTIS 2 |
| SHELL | ALVANIA G2 |
| SHELL | MOBILUX MP2 |

Table 3

E210 and E220 VAR02: Once maximum travel is attained (see tabel 1) it becomes necessary to readjust value P by using the spacers incorporated in the assembly

4.2 Spare Parts

Friction parts wear according to the amount of clutch work which, after a particular running time, requires the simultaneous replacement of the rotors (203) or (204) and the moving armature assembly (331).

5 Electrical connection

E210 and E220 clutches have to be supplied with direct current and are factory fitted with 500 mm long wires. The polarity does not affect operation.

5.1 Important recommendations



All works on the electrical connections have to be made with power off.



Ensure compliance with the nominal supply voltage (inadequate supply causes a reduction in the starting distance and transmissible torque).

The connecting wires should be of sufficient diameter to prevent voltage drops between the source and equipment supplied.

| I (A) / L (m) | 0 to 10 m | from 10 to 20 m |
|----------------------|---------------------|------------------------|
| 0 to 3 (A) | 1,5 mm ² | 1,5 mm ² |
| 3 to 6 (A) | 1,5 mm ² | 2,5 mm ² |

Tolerance in the supply voltage to the clutch terminals
+5% / -10% (NF C 79-300).

5.2 Supply

For controlling these clutches, we advise the use of Warner Electric' supply units.

Sizes 400 to 1600:

CBC 400-24, CBC 450-24
CBC 500-24, CBC 550-24
CBC 140-5

Sizes 3200 to 12800:

CBC 140-5

Warner Electric supply units provide protection for coils and circuits. Where a clutch is used without our supply units, with switching on the DC, it is essential for the coil to be protected against surges by a varistor fitted in parallel.

VAR 00 E210

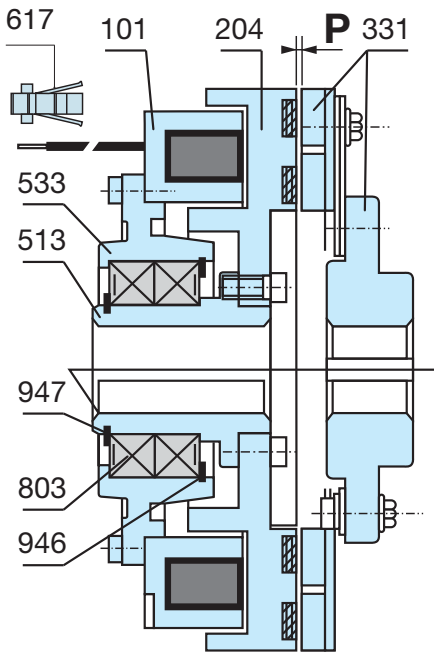

E220

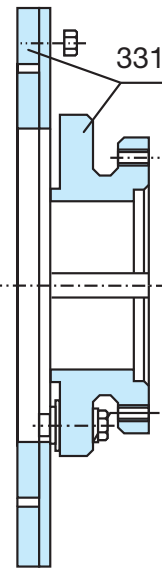

VAR 02

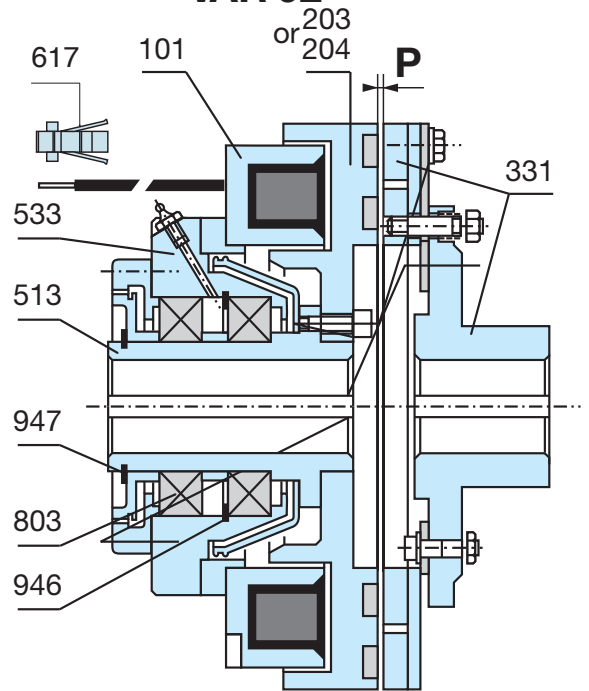

ERD VAR05

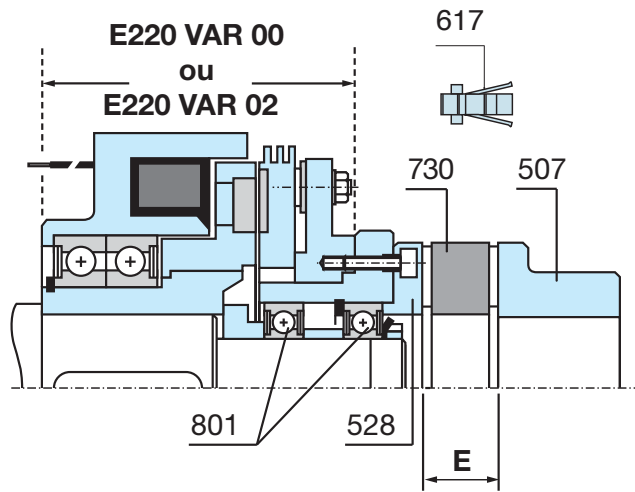

| Nr | Description |
|-----|-----------------------------------|
| 101 | Magnet |
| 203 | 4 poles rotor |
| 204 | 4 poles rotor + friction material |
| 331 | Armature plate assy |
| 507 | Coupling hub |
| 513 | Sleeve |
| 528 | Coupling flange |
| 533 | Case |
| 617 | Connector kit (Option) |
| 730 | Spider |
| 801 | Ball bearings |
| 803 | Centering ball bearing |
| 946 | Inside circlips |
| 947 | Outside circlips |

Warranty

Warner Electric LLC warrants that it will repair or replace (whichever it deems advisable) any product manufactured and sold by it which proves to be defective in material or workmanship within a period of one (1) year from the date of original purchase for consumer, commercial or industrial use.

This warranty extends only to the original purchaser and is not transferable or assignable without Warner Electric LLC's prior consent.

Warranty service can be obtained in the U.S.A. by returning any defective product, transportation charges prepaid, to the appropriate Warner Electric LLC factory. Additional warranty information may be obtained by writing the Customer Satisfaction Department, Warner Electric LLC, 449 Gardner Street, South Beloit, Illinois 61080, or by calling 815-389-3771.

A purchase receipt or other proof of original purchase will be required before warranty service is rendered. If found defective under the terms of this warranty, repair or replacement will be made, without charge, together with a refund for transportation costs. If found not to be defective, you will be notified and, with your consent, the item will be repaired or replaced and returned to you at your expense.

This warranty covers normal use and does not cover damage or defect which results from alteration, accident, neglect, or improper installation, operation, or maintenance.

Some states do not allow limitation on how long an implied warranty lasts, so the above limitation may not apply to you.

Warner Electric LLC's obligation under this warranty is limited to the repair or replacement of the defective product and in no event shall Warner Electric LLC be liable for consequential, indirect, or incidental damages of any kind incurred by reason of the manufacture, sale or use of any defective product. Warner Electric LLC neither assumes nor authorizes any other person to give any other warranty or to assume any other obligation or liability on its behalf.

WITH RESPECT TO CONSUMER USE OF THE PRODUCT, ANY IMPLIED WARRANTIES WHICH THE CONSUMER MAY HAVE ARE LIMITED IN DURATION TO ONE YEAR FROM THE DATE OF ORIGINAL CONSUMER PURCHASE. WITH RESPECT TO COMMERCIAL AND INDUSTRIAL USES OF THE PRODUCT, THE FOREGOING WARRANTY IS IN LIEU OF AND EXCLUDES ALL OTHER WARRANTIES, WHETHER EXPRESSED OR IMPLIED BY OPERATION OF LAW OR OTHERWISE, INCLUDING, BUT NOT LIMITED TO, ANY IMPLIED WARRANTIES OF MERCHANTABILITY OR FITNESS.

Some states do not allow the exclusion or limitation of incidental or consequential damages, so the above limitation or exclusion may not apply to you. This warranty gives you specific legal rights and you may also have other rights which vary from state to state.

Changes in Dimensions and Specifications

All dimensions and specifications shown in Warner Electric catalogs are subject to change without notice. Weights do not include weight of boxing for shipment. Certified prints will be furnished without charge on request to Warner Electric.



Warner Electric Europe
7 rue Champfleury, B.P. 20095, St Barthelemy d'Anjou - France
+33 (0)2 41 21 24 24 • Fax: +33 (0)2 41 21 24 70
www.warnerelectric.com