

Hydraulic Multi-Disc Brake H420

Service Manual

P-2067-WE
SM320gb - rev 02/09



 **Warner**[®]
Electric

An Altra Industrial Motion Company

We, **WARNER ELECTRIC EUROPE**, 7, rue Champfleury, B.P. 20095, F-49182 St Barthélemy d'Anjou Cedex declare that the brakes made in our factories from St Barthélemy d'Anjou,

and hereafter designated : **H420**

are intended to be incorporated in an installation or to be assembled with other machinery with a view to constituting a machine to which directive 98/37/EC.

Drawn up in St Barthélemy d'Anjou, July 2002

E. PRAT, General Managing Director

CONTENTS

1	Technical specification	2	4	Maintenance	
2	Precautions and restrictions on use	2	4.1	Maintenance	3
2.1	Restrictions on use	2	4.2	Spare parts	3
2.2	Precautions in use and safety measures	2	4.3	Dismantling / reassembling	3-4
3	Installation	3	5	Hydraulic connection	4
3.1	Transport - storage	3	5.1	Important recommendations	4
3.2	Handling	3	5.2	Hydraulic oils	4
3.3	Installation	3	5.3	Connection diagrams	5
3.4	Manual release	3	6	Appendix	6
			7	Troubleshooting	6

1 Technical specifications

VAR 00	STANDARD Size	90	150	250	550	1000	3200	6400	12800
	Max speed min ⁻¹	5000	5000	4200	3500	2500	1700	1400	1100
	P min. bar	29	24	21	23	22	22	35	35
	P max. bar	320	320"	320	320	320	350	350	350
VAR 01	HIGH TORQUE Size	150	220	330	730	1600			
	Max speed min ⁻¹	5000	5000	4200	3500	2500			
	P min. bar	48	36	28	31	36			
	P max. bar	320	320	320	320	320			
	Hydraulic connection NF E03-004 -	RP 1/8"	RP 1/8"	RP 1/4"	RP 1/4"	RP 1/4"	RP 3/8"	RP 1/2"	RP 1/2"
	Locking screws (909) -	12 x M8	12 x M8	12 x M8	12 x M10	12 x M12	12 x M16	12 x M20	12 x M24
	Tightening torque Nm	38	38	38	75	130	325	637	700
	Releasing screw -	2 x M6	3 x M6	3 x M6	3 x M8	3 x M8	3 x M10	3 x M16	6 x M16
	Length mm	20	20	25	30	30	35	40	80
	Oil change, filling and oil level cap (936, 937, 939) -	2 x M8	3 x M8	3 x M8	3 x M12	3 x M12	3 x M14	3 x M20	3 x M20
	Weight Kg	6,0	8,2	12,0"	20,0	37,5	119	196	360

NB: Data for catalogue equipment

Table 1

2 Precautions and restrictions on use



Symbol designating an action that might damage the apparatus



Symbol designating an action that might be dangerous to human safety

2.1 Restrictions on use



This equipment is designed for the disc stack to run in oil. Dry operation is possible, but only in a static application.



Exceeding the maximum rotation speed stated in the catalogue invalidates the warranty.



This equipment is designed to run with the shaft horizontal.

2.2 Precautions in use and safety measures



During maintenance, ensure that the mechanism to be braked by the equipment is at rest and that there is no risk of accidental start-up. All intervention have to be made by qualified personnel, owning this manual.



Any modification made to the brake without the express authorisation of a representative of Warner Electric, in the same way than any use out of the contractual specifications accepted by "Warner Electric", will result in the warranty being invalidated and Warner Electric will no longer be liable in any way with regard to conformity.

3 Installation

3.1 Transport / storage

The brakes are supplied in packaging guaranteeing a preservation period of 6 months with land or air transport, or after transport by ship to neighbouring continents (without crossing the tropics).

3.2 Handling

The brake is supplied assembled, the hub (515) precentred in place.

Be careful not to release the disk stack before assembly.



Avoid any impacts on the equipment so as not to alter their performance.

3.3 Installation

The hub (515) is normally supplied to H7 tolerances for bore and P9 for the width of the keyway (in accordance with NF E 22-175 / DIN 6885 / BS 4235 / ISO R773).

- Locate the hub on the shaft (after adjusting the key) and fix it axially

NB: For VAR00 sizes 90 / 150 / 250 and VAR01 sizes 150 / 220 / 330, the hub (515) should be fitted in the right direction: the largest diameter towards the shoulder of the shaft.

- Slide the equipment into position in the centring provided, having first directed the supply to the top position of the vertical axis, while presenting the hollows of the steel or sintered inner disc (308) or (309) opposite to the hub teeth (515)
- Pivot the assembly until the fixing holes coincide with the bolt ways in the brake.
- Fix the brake with the bolts provided for the purpose



Do not forget to tighten the locking screws (909) to the torque (table 1) and to secure them with a Loctite 243 type or equivalent product.

- Connect the hydraulics (see table 1)

In the case of operation in oil only:

- Remove the filling cap (937) and oil level cap (939) (the lowest of the plugs located at the back). Pour in the oil (see chap. 5 for the choice) up to the level required. Replace the caps

3.4 Manual Release

Brakes in the H420 range can be released manually so as to put the brake out of operation, in the event of a fault in the hydraulic circuit or for maintenance. To do this, the caps (939) must be removed so as to access the tapped holes provided in the piston (402). Fit a set of bolts (given in table 1) and screw them right in to compress the springs.

4 Maintenance

4.1 Maintenance

There is practically no wear on the discs of units in the H420 range if the running conditions are complied with (operation in oil, oil temperature, rotation speed, etc.). Disc wear is automatically compensated for, up to the wear limit, by the movement of the piston. It is however necessary to:

- Regularly check the piston seal (402) and in the event of a leak or after 5 years use, change the seals (703, 704) and back-up rings (722, 723)

In the case of operation in oil only:

- Change the oil after 40 h running from first use, then every year of normal running.

4.2 Spare parts

For all orders of spare parts, state the size of the equipment with its code number, the part number (see Appendix) and the quantity required.

4.3 Dismantling / reassembling



During the maintenance period, ensure that the mechanism to be braked by the equipment is at rest and that there is no risk of accidental start-up. Also ensure that the hydraulic supply is shut off.

After removing the equipment from the shaft, proceed as follows:

- Where the equipment is running in oil, drain it
- Manually release the equipment's brake
- Remove the pre-assembly screws and remove the closing plate (359) with the piston (402) and springs (740)

- Remove the manual braking screws and replace the caps (939)
- Refit the brake as described in paragraph 3.3



Do not forget to tighten the fixing bolts to torque (see Table 1) and to secure them with a Loctite 243 or equivalent type product.

Changing the disk stack:

- Remove the flange (357)
- Remove the worn disk stack
- Put the new set of disks in place, starting with an outer disc (303 or 304), followed by an inner disc (308 or 309) and ending with an outer disc
- Do not forget to seal the faces of the flange (357) and of the closing plate (359), with an anaerobic material (Loctite 549, for example)



Ensure compliance with the operating pressure so as to get the equipment's nominal performance.



Ensure that the maximum pressure is not exceeded (see table 1).



We recommend filtration of the control of about 10 microns so as to guarantee trouble-free running and a correct life of the hydraulic components.



The disc lubricating oil should not exceed 80°C in operation.

Changing the seals:

- Do not forget to replace the back-up rings (722) and (723) with the seals (703) and (704) situated on the pressure chamber side
- Before reassembling, lightly oil slip surfaces with control oil
- Reassemble the closing plate (359) with the piston (402)
- Equipment of sizes 3200 to 12800 contain seals (706) fitted on the flange (357) and closing plate (359): check their condition and change if necessary

5.2 Hydraulic Oils

The types of oil to use for lubricating the discs should fulfil the following criteria:

- Good resistance to oxidation
- No additives modifying friction
- No additives that could corrode the bronze friction surfaces (1a or 1b NF M07-015)
- Compatible with the materials used for the hydraulic seals
- High viscosity rating (>80)

The oils listed below meet these characteristics, this list is not exhaustive and can be added to by other oils. The viscosity of the oil to choose varies according to temperature and running speed (measured on the ext. dia. of the cylinder).



Do not damage the seals during reassembly.

- Replace the fixing bolts in the closing plate (359)
- Use the hub (515) to align the teeth of the interior disc stack.

	Mineraloil			ATF
Viscosity Running Speed	ISO VG 22 > 12 m/s	ISO VG 32 > 12 m/s	ISO VG 46 > 12 m/s	> 12 m/s
BP ESSO MOBIL SHELL ELF	Nuto H22 DTE 22 Tellus 22	Energol HLP-D32 Nuto h 32 DTE Oil Light Tellus 32 Polytelis 32	Energol HLP-D46 Nuto H 46 DTE Oil Medium Tellus 46 Polytelis 46	Autran MBX AT Dexron II ATF 220 Donax TM Elfmatic G2"

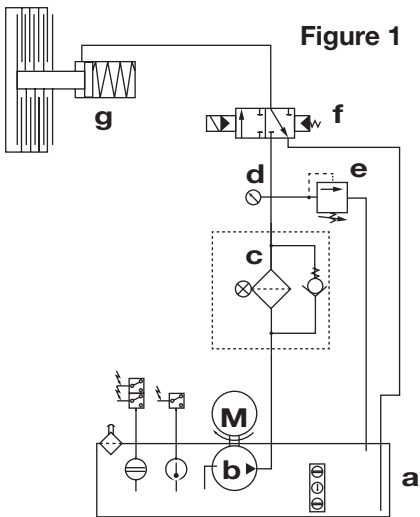

Figure 1

Figure 1: Basic circuit for multidisc brake with hydraulic release

- a: Reservoir
- b: Pump
- c: Filter
- d: Pressure gauge
- e: Pressure limiter
- f: Distributor
- g: Brake

The brake is lubricated by splashed non renewed oil.

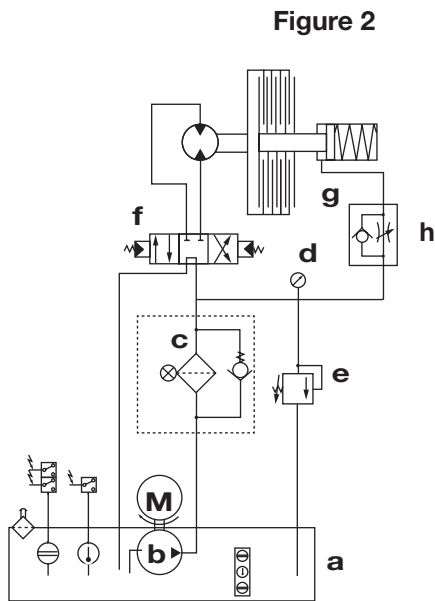

Figure 2

Figure 2: Hydraulic release, multidisc brake assembly in open circuit with hydraulic motor

- a: Reservoir
- b: Pump
- c: Filter
- d: Pressure gauge
- e: Pressure limiter
- f: Distributor
- g: Brake
- h: Flow restricter with non-return valve

The distributor in central position causes the oil to return to the reservoir and the brake to close. Going to one of the two other positions causes the brake to open and the hydraulic motor to rotate, in one or other direction, according to the position of the slider.

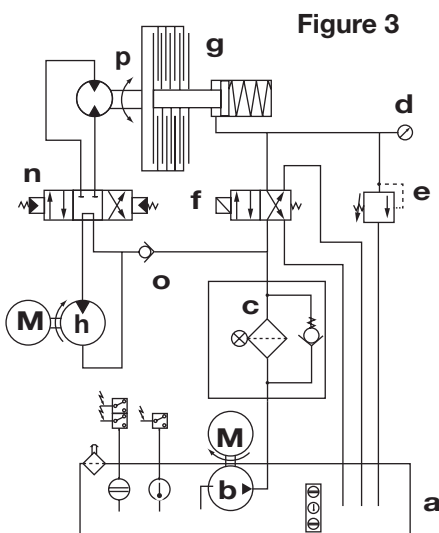

Figure 3

Figure 3: Hydraulic release, multidisc brake assembly in closed circuit with hydraulic motor

- a: Reservoir
- b: Pump
- c: Filter
- d: Pressure gauge
- e: Pressure limiter
- f: Distributor
- g: Brake
- h: Pump
- n: Distributor
- o: Calibrated non-return valve
- p: Hydraulic motor

The distributor for the hydraulic motor and brake are controlled simultaneously causing the brake to release and the motor to rotate.

6 Appendix

Size 90 to 12800 : VAR00

Size 150 to 1600 : VAR01

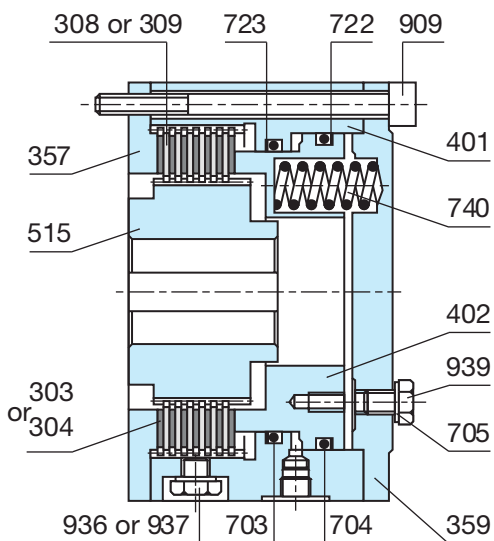

NO.	Description
303	Steel outer disc
304	Stintered outer disc
308	Steel inner disc
309	Stintered inner disc
357	Flange
359	Closing plate
401	Cylinder
402	Piston
515	Hub
703	Cylinder Quad ring seal
704	Piston Quad ring seal
705	Flat ring
722	Back up ring piston
723	Back up ring cylinder
740	Spring
909	Locking screw
936	oil chang cap
937	Filling cap
939	Oil level cap

7 Troubleshooting

Troubleshooting		
Problem	Possible Causes	Remedies
The brake does not brake	<ul style="list-style-type: none"> • Brake under hydraulic pressure • Manual release screw in position • Disc worn or damaged 	<ul style="list-style-type: none"> • Check the circuit control • Remove the manual release screws • Change the disc
The brake does not release	<ul style="list-style-type: none"> • Piston seals worn or damaged • No pressure • No sufficient pressure 	<ul style="list-style-type: none"> • Change the seals • Check the hydraulic circuit and control • Increase the pressure

Warranty

Warner Electric LLC warrants that it will repair or replace (whichever it deems advisable) any product manufactured and sold by it which proves to be defective in material or workmanship within a period of one (1) year from the date of original purchase for consumer, commercial or industrial use.

This warranty extends only to the original purchaser and is not transferable or assignable without Warner Electric LLC's prior consent.

Warranty service can be obtained in the U.S.A. by returning any defective product, transportation charges prepaid, to the appropriate Warner Electric LLC factory. Additional warranty information may be obtained by writing the Customer Satisfaction Department, Warner Electric LLC, 449 Gardner Street, South Beloit, Illinois 61080, or by calling 815-389-3771.

A purchase receipt or other proof of original purchase will be required before warranty service is rendered. If found defective under the terms of this warranty, repair or replacement will be made, without charge, together with a refund for transportation costs. If found not to be defective, you will be notified and, with your consent, the item will be repaired or replaced and returned to you at your expense.

This warranty covers normal use and does not cover damage or defect which results from alteration, accident, neglect, or improper installation, operation, or maintenance.

Some states do not allow limitation on how long an implied warranty lasts, so the above limitation may not apply to you.

Warner Electric LLC's obligation under this warranty is limited to the repair or replacement of the defective product and in no event shall Warner Electric LLC be liable for consequential, indirect, or incidental damages of any kind incurred by reason of the manufacture, sale or use of any defective product. Warner Electric LLC neither assumes nor authorizes any other person to give any other warranty or to assume any other obligation or liability on its behalf.

WITH RESPECT TO CONSUMER USE OF THE PRODUCT, ANY IMPLIED WARRANTIES WHICH THE CONSUMER MAY HAVE ARE LIMITED IN DURATION TO ONE YEAR FROM THE DATE OF ORIGINAL CONSUMER PURCHASE. WITH RESPECT TO COMMERCIAL AND INDUSTRIAL USES OF THE PRODUCT, THE FOREGOING WARRANTY IS IN LIEU OF AND EXCLUDES ALL OTHER WARRANTIES, WHETHER EXPRESSED OR IMPLIED BY OPERATION OF LAW OR OTHERWISE, INCLUDING, BUT NOT LIMITED TO, ANY IMPLIED WARRANTIES OF MERCHANTABILITY OR FITNESS.

Some states do not allow the exclusion or limitation of incidental or consequential damages, so the above limitation or exclusion may not apply to you. This warranty gives you specific legal rights and you may also have other rights which vary from state to state.

Changes in Dimensions and Specifications

All dimensions and specifications shown in Warner Electric catalogs are subject to change without notice. Weights do not include weight of boxing for shipment. Certified prints will be furnished without charge on request to Warner Electric.



Warner Electric Europe
7 rue Champfleury, B.P. 20095, St Barthelemy d'Anjou - France
+33 (0)2 41 21 24 24 • Fax: +33 (0)2 41 21 24 70
www.warnerelectric.com