

# Preassembled Clutch/Electrically Released Brake Module

Installation Instructions

P-273-2-WE  
819-0346



 **Warner**<sup>®</sup>  
Electric

An **Altra Industrial Motion** Company

# Contents

Introduction . . . . . 2  
 Mounting to a Motor . . . . . 3  
 Mounting to a Reducer . . . . . 3  
 Installing the Base Mount. . . . . 4  
 Installing the Motor Mount . . . . . 4  
 Electrical Connections . . . . . 5  
 Start-Up . . . . . 6  
 Coil Data . . . . . 6  
 Warranty . . . . . back cover

**⚠ WARNING** Failure to follow these instructions may result in product damage, equipment damage, and serious or fatal injury to personnel.

## Introduction

Warner Electric’s Unimodule has been designed to NEMA standards and can be installed with all standard power transmission drive systems.

Before installing the Unimodule to a motor or reducer, make certain that the UM Unimodule size and NEMA frame dimensions match according to the following chart.

Corresponding NEMA Frame Sizes				
UM Size	Old NEMA	New NEMA	Shaft Dia.	C-Face Pilot Dia.
50	56 C	48 Y	5/8	4 1/2
100	56 C	48 Y	5/8	4 1/2
180	182 C 184 C	143 TC 145 TC	7/8	4 1/2
210	213 C 215 C	182 TC 184 TC	1-1/8	8 1/2
215		213 TC 215 TC	1 3/8 1 3/8	8 1/2 8 1/2

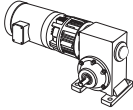
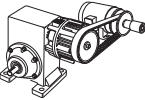
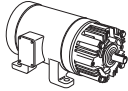
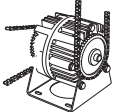
For These UM Combination	Use These Installation Steps:
 UniModule Clutch-ER Brake Between C-Face Motor and Reducer – 1020 FBC	Mounting to a Motor Mounting to a Reducer Electrical Connections Start Up
 UniModule Clutch-Brake - 2030 FBC	Chain or pulley Drive to a Reducer Electrical Connection Start Up
 Motor Mount Unimodule Clutch-Brake on a C-Face Motor - 1020-FBC-M	Mounting to a Motor Installing the Motor Mount Electrical Connection Start Up
 Base Mounted Unimodule Clutch-Brake - 2030-FBC-B	Installing the Base Mmount Electrical Connection Start Up

Install your specific modular combination according to the installation steps specified in the table. Use only those steps indicated for each combination.

The 1020 and 1040 UniModules are furnished with a special hardened key. It is strongly recommended that this key be used with the motor shaft to avoid damage to the shaft and rotor hub.

The size 210 UniModules require an adapter ring to be mounted to the motor prior to mounting the 1020 or 1040 UniModule. Adapter and mounting hardware are provided with the UniModule assembly.

**Note: The equipment covered by this service manual must be installed in accordance with these instructions. Failure to do so may damage the equipment and void the warranty.**

## Mounting to a Motor

1. Replace the existing motor shaft key with the hardened key provided with the unit. If necessary, prick punch the keyway of the motor shaft to keep the key from moving in the keyway. Slide the module assembly onto the motor shaft. (See Figure 1) Align the key in the motor shaft with the keyway in the rotor hub.

Do not use force. If the UniModule does not slide on freely, polish the motor shaft sufficiently to achieve a slip fit.



Figure 1

2. The housing is provided with vent holes which are normally placed in the down position. Rotate the assembly to where the vent holes are toward the bottom and insert the four long capscrews (provided) through the mounting holes in the housing and into the motor face. Tighten alternately and securely. (30 to 35 ft. lbs.)

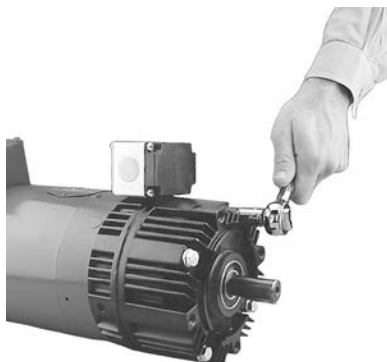

Figure 2

3. The access hole for the Allen wrench to tighten the rotor setscrews is shown in Figure 3. Rotate the clutch rotor as necessary to insert the wrench into the setscrews. Tighten both screws alternately and securely. (40 to 45 in. lbs. for 180 size, 80 to 85 in. lbs. for 50 and 210 sizes.)



Figure 3

## Mounting to a Reducer

The output side of a Unimodule may be mounted directly to a reducer.

- A. Align the output shaft and key of the Unimodule with the corresponding shaft hole and keyway of the reducer. Slide the assembly together, matching the pilot diameter on the Unimodule with a pilot diameter on the reducer.
- B. Bolt the Unimodule to the reducer flange. The four (4) bolts required (3/8-16 UNC-2A) are normally furnished with the reducer. (18 to 22 ft. lbs. for 50 and 180 sizes, 40 to 45 lbs. for 210 size.)

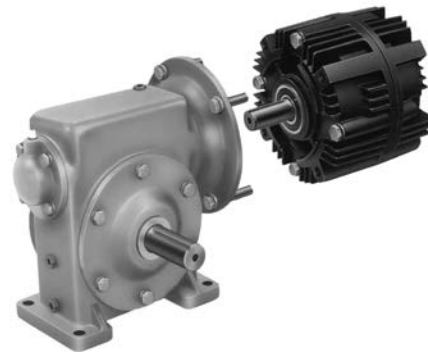

Figure 4

## Installing the Base Mount

Unimodules 2030 FBC can be base-mounted (Figure 5).



Figure 5

- A. Mount each Unimodule so that the base is located below the ventilation holes. A pilot diameter on the end of each Unimodule mates with pilot diameters on the base.
- B. Secure the base to the Unimodule with the four (4) bolts provided. (18 to 22 ft. lbs. for 50 and 180 sizes, 40 to 45 ft. lbs. for 210 size.)

## Installing the Motor Mount (M)

A Motor Mount (M) can be installed to the Unimodule output end to provide a foot mounting for the complete assembly of Unimodule and motor.

### Size 50 and 180

- A. Remove the two (2) long hex head bolts from the side of the Unimodule toward the ventilation holes.
- B. Mount the Unimodule on the Motor Mount so that the base of the Motor Mount is underneath the Unimodule and motor (Figure 6). A pilot diameter on the Unimodule mates with a pilot diameter on the Motor Mount.
- C. Secure the Motor Mount in place with two (2) longer mounting bolts (30 to 35 ft. lbs.) and the two shorter bolts (18 to 22 ft. lbs.) all provided in the kit.

### Size 210

- A. Mount the Unimodule on the Motor Mount so that the base of the Motor Mount is underneath the Unimodule and motor (Figure 6). A pilot diameter on the Unimodule mates with a pilot diameter on the Motor Mount.
- B. Secure the Motor Mount to the Unimodule with three (3) bolts provided. (40 to 45 ft. lbs.)



Figure 6

## Electrical Connections

**⚠ WARNING** To avoid injury (or even death), always make certain all power is off before attempting to install or service this control or any electrical equipment.

The Unimodule is provided with one conduit connection hole, threaded for standard 1/2" conduit connectors. Both the clutch and the brake lead wires are brought out through this opening. The conduit box accessory kit, P/N 5370-101-042, provides two conduit connection holes for standard 1/2" conduit connectors.

The clutch and brake coils operate on DC voltage. The brake must be controlled by an adjustable current or voltage supply for optimum release. Warner Electric offers a complete line of controls to meet the needs of almost any application. The service and installation instruction, included with each Warner Electric control detail the proper electrical connections.

## Electrical Connections and Control Requirements

- A. The wiring diagram included with each Warner Electric control shows the proper electrical connections to be made.
- B. Controls used must have adjustable output voltage.
- C. All Permanent Magnet Type Electrically Released Brake Modules are polarity sensitive. Therefore, the (+) red wire must be connected to the (+) terminal and the (-) black wire to the (-) terminal.

90 Volt Brake recommended controls are:

CBC-300  
CBC-500-90  
CBC-550-90

24 Volt Brake recommended controls are:

CBC-500-24  
CBC-550-24

**The positive side of the adjustable supply must be connected to the red lead of the brake. Please refer to the figure below for the proper electrical connections. Clutch leads are identified with a white insulator sleeve. Brake leads have a black insulator sleeve.**

## Brake Release Adjustment

**Instructions for setting the optimum release voltage of permanent magnet applied/electrically released brakes.**

**▲CAUTION** The following procedure will result in the brake releasing and allowing the load to be free to move. Be sure the load is in a safe condition before proceeding with this process.

In a permanent magnet applied/electrically released brake, the attractive force between the brake surfaces is created by permanent magnets. The brake is electrically released by applying DC power to the electro-magnetic coil in the brake that opposes the permanent magnets. Electrically released brakes are polarity sensitive: the positive lead of the power supply must be connected to the positive (red) lead of the brake, and the negative lead of the power supply must be connected to

the negative (black) lead of the brake. The power supply applied to the brake must also be adjustable so that the optimum release voltage for each individual brake can be determined and set.

The following procedure describes how to set the adjustable power supply to the optimum release point of the brake. A volt-meter is required to perform the procedure.

**▲CAUTION** No power is applied to motor during this procedure. Power normally supplied by motor to brake control should be supplied by alternate method.

1. With power off, connect the positive lead of the power supply to the positive (red) lead of the brake and the negative lead of the power supply to the negative (black) lead of the brake.
2. Connect a volt-meter to measure the voltage applied across the brake.
3. Adjust the power supply to its lowest possible output, then energize the power supply only, to apply power to the brake.
4. Starting from the low point, slowly increase the applied voltage until the brake armature disengages from the magnet. Note and record the applied voltage at this point.
5. Continue to slowly increase the applied voltage until the armature re-engages the magnet. If the maximum voltage available from the supply does not cause the armature to re-engage, the armature should be manually assisted into engagement.

**NOTE: If armature needs to be manually assisted, armature should be pressed on back side to make contact with friction face of magnet.**

6. With the armature re-engaged, slowly reduce the applied voltage until the armature disengages from the magnet. Note and record the applied voltage at this point.
7. The optimum release point for the brake is half-way between the two recorded voltage readings. Adjust the supply to this optimum release voltage.

**NOTE: The above procedure should be done by visually watching the armature move and may be repeated if necessary from Step 1 through Step 7.**

## Start-Up

With the motor at rest, check the following:

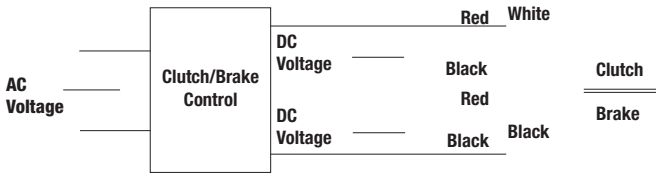

- A. With the brake energized, spin the output shaft by hand to insure that it turns freely.
- B. With the clutch/brake control energized, switch back and forth between the clutch and brake and observe the armatures (plates) through the vent holes and opening in the fan. They should move back and forth approximately 1/32" when switched.
- C. If a scraping sound is noted when the output shaft is spun, it means an armature is dragging slightly because of shock and displacement during shipment. This is easily corrected.

Insert a screwdriver through the vent holes and slot in the fan and pry the dragging armature\* (clutch or brake as observed) away from the mating surface evenly all the way around as far as it will move. Then insert the screwdriver between the two armatures (back to back) and pry it evenly back into complete contact. This will reset the autogap in the proper position and the unit should now be ready for further assembly in the drive system and normal operation. If dragging armature is on the brake side, the brake must be energized during adjustment.

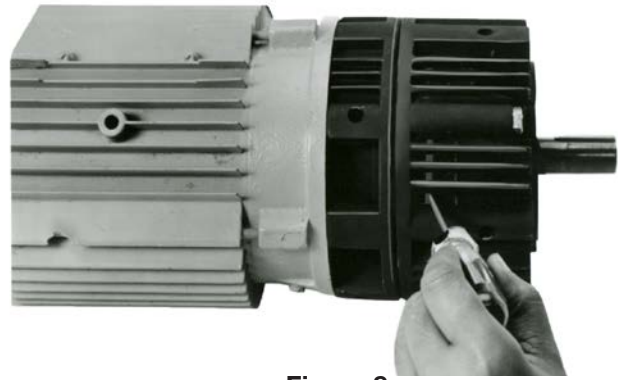

Figure 8

## Electrical Coil Data: (UMFBC)

Voltage-D.C.		Clutch 90	Brake 90	Clutch 24	Brake 24
Resistance (OHMS)	UM-50	452	447	31.8	29.2
	UM-180	392	308	26.7	21.7
	UM-210	248	203	17.9	13.6
AMPERES	UM-50	.199	.201	.755	.822
	UM-180	.230	.292	.896	1.11
	UM-210	.363	.443	1.34	1.76
WATTS	UM-50	18	18	18	19.7
	UM-180	20.7	26.3	21.5	26.6
	UM-210	32.7	40	32	42.2
Build Up (Milliseconds)	UM-50	52	40	52	40
	UM-180	72	80	72	80
	UM-210	120	90	120	90
Decay (Milliseconds)	UM-50	6.2	5	6.2	5
	UM-180	12	8	12	8
	UM-210	20	10	20	10

## Mechanical Data

	UM-50	UM-180	UM-210
Static Torque Maximum Speed	10.5 lb. ft. 3600 rpm	21 lb. ft. 3600 rpm	56 lb. ft. 3600 rpm
Average Weight-lbs.:			
Motor Clutch	3.4 lbs.	5.1 lbs.	9.1 lbs.
Brake	6.6	8.1	21.5
Input Clutch	6.4	8.4	19.8
Output Clutch	4.9	5.2	15.2
Inertia - WR	.007 lb. ft.	.018 lb. ft.	.081 lb. ft.
Armature	0.002	0.003	0.021
Armature hub Shaft	0.001	0.002	0.017
Rotor w/Fan and hub	0.020	0.046	0.188





## Warranty

Warner Electric LLC warrants that it will repair or replace (whichever it deems advisable) any product manufactured and sold by it which proves to be defective in material or workmanship within a period of one (1) year from the date of original purchase for consumer, commercial or industrial use.

This warranty extends only to the original purchaser and is not transferable or assignable without Warner Electric LLC's prior consent.

Warranty service can be obtained in the U.S.A. by returning any defective product, transportation charges prepaid, to the appropriate Warner Electric LLC factory. Additional warranty information may be obtained by writing the Customer Satisfaction Department, Warner Electric LLC, 449 Gardner Street, South Beloit, Illinois 61080, or by calling 815-389-3771.

A purchase receipt or other proof of original purchase will be required before warranty service is rendered. If found defective under the terms of this warranty, repair or replacement will be made, without charge, together with a refund for transportation costs. If found not to be defective, you will be notified and, with your consent, the item will be repaired or replaced and returned to you at your expense.

This warranty covers normal use and does not cover damage or defect which results from alteration, accident, neglect, or improper installation, operation, or maintenance.

Some states do not allow limitation on how long an implied warranty lasts, so the above limitation may not apply to you.

Warner Electric LLC's obligation under this warranty is limited to the repair or replacement of the defective product and in no event shall Warner Electric LLC be liable for consequential, indirect, or incidental damages of any kind incurred by reason of the manufacture, sale or use of any defective product. Warner Electric LLC neither assumes nor authorizes any other person to give any other warranty or to assume any other obligation or liability on its behalf.

WITH RESPECT TO CONSUMER USE OF THE PRODUCT, ANY IMPLIED WARRANTIES WHICH THE CONSUMER MAY HAVE ARE LIMITED IN DURATION TO ONE YEAR FROM THE DATE OF ORIGINAL CONSUMER PURCHASE. WITH RESPECT TO COMMERCIAL AND INDUSTRIAL USES OF THE PRODUCT, THE FOREGOING WARRANTY IS IN LIEU OF AND EXCLUDES ALL OTHER WARRANTIES, WHETHER EXPRESSED OR IMPLIED BY OPERATION OF LAW OR OTHERWISE, INCLUDING, BUT NOT LIMITED TO, ANY IMPLIED WARRANTIES OF MERCHANTABILITY OR FITNESS.

Some states do not allow the exclusion or limitation of incidental or consequential damages, so the above limitation or exclusion may not apply to you. This warranty gives you specific legal rights and you may also have other rights which vary from state to state.

### Changes in Dimensions and Specifications

All dimensions and specifications shown in Warner Electric catalogs are subject to change without notice. Weights do not include weight of boxing for shipment. Certified prints will be furnished without charge on request to Warner Electric.



[www.warnerelectric.com](http://www.warnerelectric.com)

31 Industrial Park Road  
New Hartford, CT 06057  
815-389-3771  
Fax: 815-389-2582

An **Altra Industrial Motion** Company

