

# UM-FBC Series | Electrically Released Brakes

## UniModule Clutch/Electrically Released Brake Combination

Warner Electric offers the convenience of pre-assembled UniModule clutch/electrically released brake packages. Assembly, alignment, and pre-burnishing have been done at the factory. Bolt it on, wire it up, and your clutch/electrically released brake is ready to go. Available in both C-face and base mounted versions.

Warner Electric's unique design employs powerful permanent magnets for maximum torque when power is removed from the brake coil. A small amount of electrical power applied to the brake coil nullifies the permanent magnets and the brake releases. No springs to limit cycle rates. Never any adjustments. No lubrication. These brakes are recommended for dynamic cycling operations only.



**GEN 2 Design**  
Sizes 50, 100 & 180

**Original Design**  
Sizes 210 & 215



### 1020-FBC

#### **Motor Clutch/Electrically Released Brake**

Use for clutch/power-off brake applications. Has clutch input and brake on output side. Employs powerful permanent magnets for maximum torque when power is removed from the brake coil. Basic components are field, rotor, 2 armatures and power-off magnet. See page 54 for specifications.



### 2030-FBC

#### **Input Clutch/Electrically Released Brake**

Use for clutch/power-off brake applications. Has shafts on input and output sides. When electrical power is applied to the brake coil the brake releases. Ideal for dynamic cycling operations. Basic components are field, rotor, 2 armatures and power-off magnet. See page 54 for specifications.



### 2030-FBC-B

#### **Input Clutch/Electrically Released Brake with Accessory Base Mounting**

See page 54 for specifications.

# Electrically Released Brakes | UM-FBC Series

## Selection

UniModule clutch/electrically released brake units may be mounted directly to NEMA C-face motors and reducers, or can be base mounted.

### 1. Select Configuration

#### a. NEMA C-face Mounting (1020 Configuration)

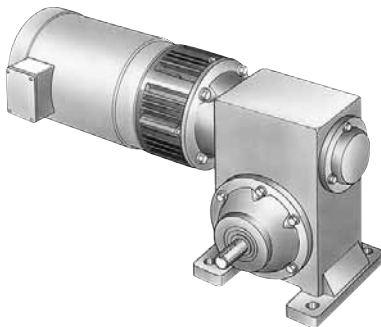

Verify the unit will be cycled frequently.

To select the correct UniModule package, determine the NEMA frame size of your motor and/or reducer, and choose the corresponding size UniModule from the Frame Size Selection chart. Verify torque ratings.

#### b. Base Mounting (2030 Configuration)

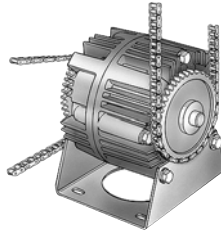

Verify the unit will be cycled frequently.

Select the correct size module from the Horsepower vs. Shaft Speed chart by determining the motor horsepower and RPM at the module location. The correct size UniModule is shown at the intersection of the HP and operating speed. For additional sizing information, refer to the technical sizing procedure (step 2).

### 2. Determine Technical Requirements

Technical considerations for sizing and selection are torque and heat dissipation. Each merits careful consideration, especially heat dissipation as over time, use in excessive temperature environments will have an adverse effect on bearing life and coil wire insulation integrity.

Compare the calculated torque requirement with the average dynamic torque ratings. Select a unit with adequate torque. If the unit selected on torque is different than the unit selected based on heat, select the larger size unit.

### Horsepower vs. Shaft Speed

HP	SHAFT SPEED AT CLUTCH (IN RPM)																	
	100	200	300	400	500	600	700	800	900	1000	1100	1200	1500	1800	2000	2400	3000	3600
1/4																		
1/2																		
3/4																		
1																		
1-1/2																		
2																		
3																		
5																		
7-1/2																		

### Frame Size Selection and Technical Ratings Chart (Blue shaded areas indicate GEN 2 design)

NEMA Frame Size	UniModule Size	Static Torque Brake lb.ft.	Static Torque Clutch lb.ft.	Max. RPM	Voltage DC
56C/48Y	UM-50*	10.5	16	3600	24 or 90
	UM-100**	21	30		
182C/143TC 184C/145TC	UM-180	21	30	3600	24 or 90
213C/182TC 215C/184TC	UM-210	56	95	3600	24 or 90
213TC/215TC	UM-215	56	95	3600	24 or 90

\*For 56C/48Y C-frame motors 3/4 HP and smaller, the UM-100 size may be used where extended life is desirable.

\*\*The UM-100 size is recommended for motors 1 HP and larger.

# UM-FBC Series | Electrically Released Brakes

## a. Heat Dissipation Sizing

Friction surfaces slip during the initial period of engagement and, as a result, heat is generated. The clutch/brake selected must have a heat dissipation rating greater than the heat generated by the application. Therefore, in high inertia or high cycle rate applications, it is necessary to check the heat dissipation carefully. Inertia, speed and cycle rate are the required parameters.

Heat dissipation requirement is calculated as follows:

$$E = 1.7 \times WR^2 \times (N/100)^2 \times F$$

where:

E = Heat (lb. ft./min.)

$WR^2$  = Total reflected inertia at the clutch/brake shaft. Include the clutch/brake output inertia. (lb.ft.<sup>2</sup>)

N = Speed in revolutions per minute (RPM)

F = Cycle rate in cycles per minute (CPM)

Compare the calculated heat generated in the application to the unit ratings using the heat dissipation curves. Select the appropriate unit that has adequate heat dissipation ability.

## Heat Dissipation Curves

### Size 50

Maximum Speed 3600 RPM

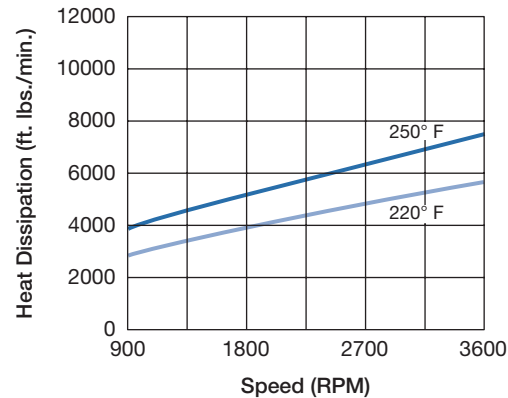

### Size 100/180

Maximum Speed 3600 RPM

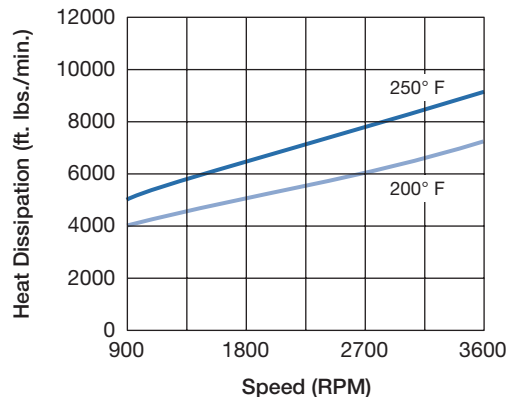

### Size 210/215

Maximum Speed 3600 RPM

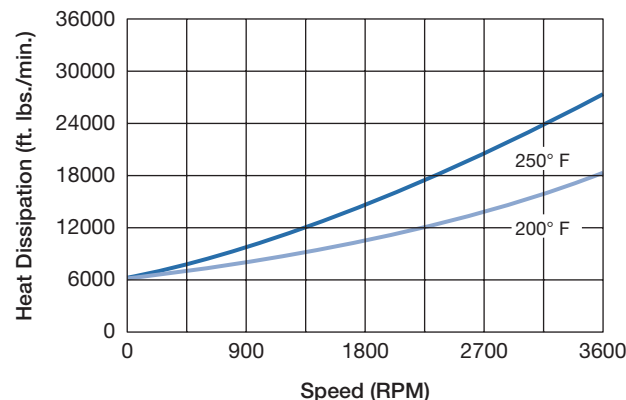

## b. Torque Sizing

For most applications, the correct size clutch/brake can be selected from the Horsepower vs. Shaft Speed chart on page 51. Determine the motor horsepower and the RPM at the clutch/brake. The correct size unit is shown at the intersection of horsepower and shaft speed.

If the static torque requirements are known, refer to the technical ratings chart to select a unit.

For some applications, the torque requirement is determined by the time allowed to accelerate and decelerate the load. (This time is generally specified in milliseconds.) For these applications, it is necessary to determine the torque requirement based on load inertia and the time allowed for engagement.

The torque requirements are calculated as follows:

$$T = (WR^2 \times N) / (308 \times t)$$

where:

T = Average Dynamic Torque (lb. ft.)

$WR^2$  = Total reflected inertia at the clutch/brake shaft. Include the clutch/brake output inertia. (lb. ft.<sup>2</sup>)

N = Speed in revolutions per minute (RPM)

t = Time allowed for the engagement (sec)

## C-face Electrically Released Brake Dynamic Torque Curves

### Size 50

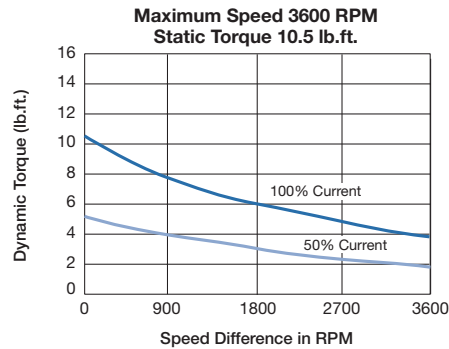

## C-face Clutch Dynamic Torque Curves

### Size 50

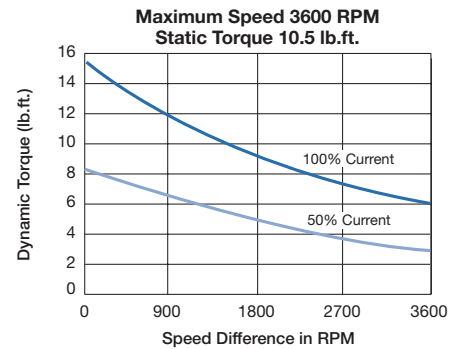

### Size 100/180

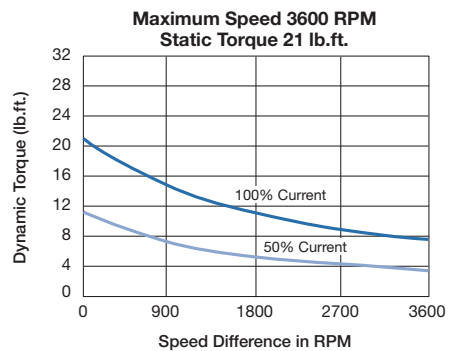

### Size 100/180

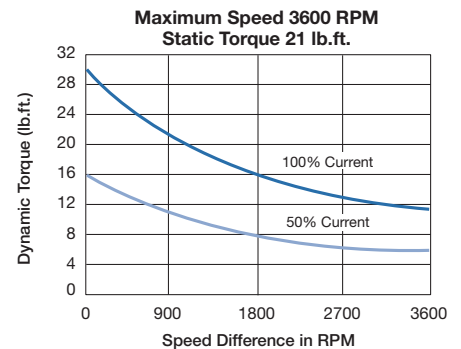

### Size 210/215

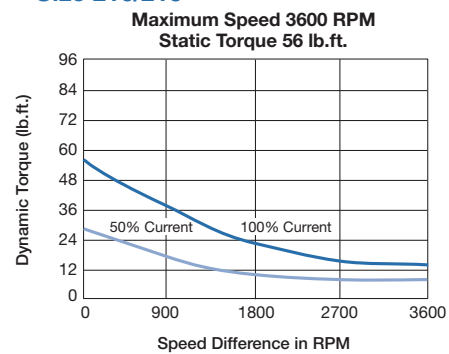

### Size 210/215

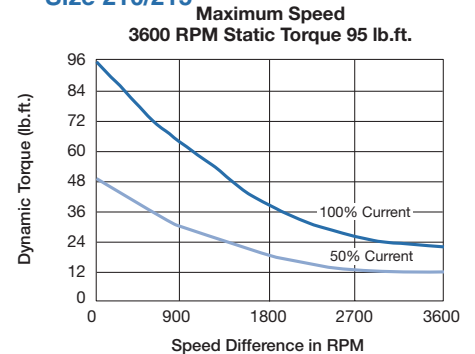

# UM-FBC Series Electrically Released Brakes

## Ordering Information

### Specifications (Max. Speed 3600 RPM) (Blue shaded areas indicate GEN 2 design)

Size	Voltage DC	Weight (lbs.)		Armature		Component Inertia—WR <sup>2</sup> (lb. ft. <sup>2</sup> )					NEMA Frame Size
		1020		2030		1020		2030			
		1020	2030	(both)	Hub	Shaft	Rotor w/Fan and Hub	Output Shaft	Input Shaft	Rotor w/Fan and Hub	
50	24 90	15.6	18.4	.018	.001	.001	.020	.001	.001	.020	56C/48Y
100	24 90	18.7	21.7	.046	.002	.002	.046	.002	.002	.046	56C/48Y
180	24 90	18.7	21.7	.046	.002	.002	.046	.002	.002	.046	182C/143TC 184C/145TC
210	24 90	36	47	.162	.016	.014	.190	.016	.015	.183	213C/182TC 215C/184TC
215	24 90	37	48	.162	.016	.016	.190	.017	.016	.183	213TC/215TC

### 3. Select Options

Warner Electric Enclosed UniModules can be fitted with several accessories to extend their capacity and ease of mounting.

### 4. Select Control

All electrically released modules require a control with a potentiometer that will vary brake channel output. UM-FBC units require either a CBC-300 or a CBC 500/550 control.

### Part Numbers (Blue shaded areas indicate GEN 2 design)

Model No.	Voltage DC	GEN 2 Part No.	Original Part No.
<b>Motor Clutch/ ER Brake</b>			
UM-50-1020FBC	24	5370-273-243	5370-273-037
UM-50-1020FBC	90	5370-273-244	5370-273-036
UM-100-1020FBC	24	5370-273-248	5370-273-153
UM-100-1020FBC	90	5370-273-249	5370-273-125
UM-180-1020FBC	24	5370-273-253	5370-273-047
UM-180-1020FBC	90	5370-273-254	5370-273-046
UM-210-1020FBC	24		5371-273-013
UM-210-1020FBC	90		5371-273-012
UM-215-1020FBC	24		5371-273-099
UM-215-1020FBC	90		5371-273-079
<b>Input Clutch/ ER Brake</b>			
UM-50-2030FBC	24	5370-273-258	5370-273-042
UM-50-2030FBC	90	5370-273-259	5370-273-041
UM-100-2030FBC	24	5370-273-263	5370-273-154
UM-100-2030FBC	90	5370-273-264	5370-273-155
UM-180-2030FBC	24	5370-273-268	5370-273-052
UM-180-2030FBC	90	5370-273-269	5370-273-051
UM-210-2030FBC	24		5371-273-018
UM-210-2030FBC	90		5371-273-017
UM-215-2030FBC	24		5371-273-100
UM-215-2030FBC	90		5371-273-101

### Accessories

Description	UM Size	Part No.
Conduit Box	UM series All sizes	5370-101-042
Base Mount Kit for 2030 FBC	50/100	5370-101-004
	180	5370-101-002
	210/215	5371-101-019
Motor Mount Kit for 1020 FBC	50/100	5370-101-078
	180	5370-101-079
	210/215	5371-101-012
Cover Kit	50/100/180	5370-101-076

### How to Order

1. Specify model number and voltage or the corresponding part number.
2. Specify conduit box, if desired.
3. Specify required control unit. See the Controls Section (page 141 in the Clutch/Brake catalog P-1234).

### Ordering Example

UM-50-1020FBC, 90V or 5370-273-244; 5370-101-042 conduit box; CBC-300 control.

# Electrically Released Brakes | UM-FBC Series

## UM-1020 FBC Motor Clutch/Electrically Released Brake

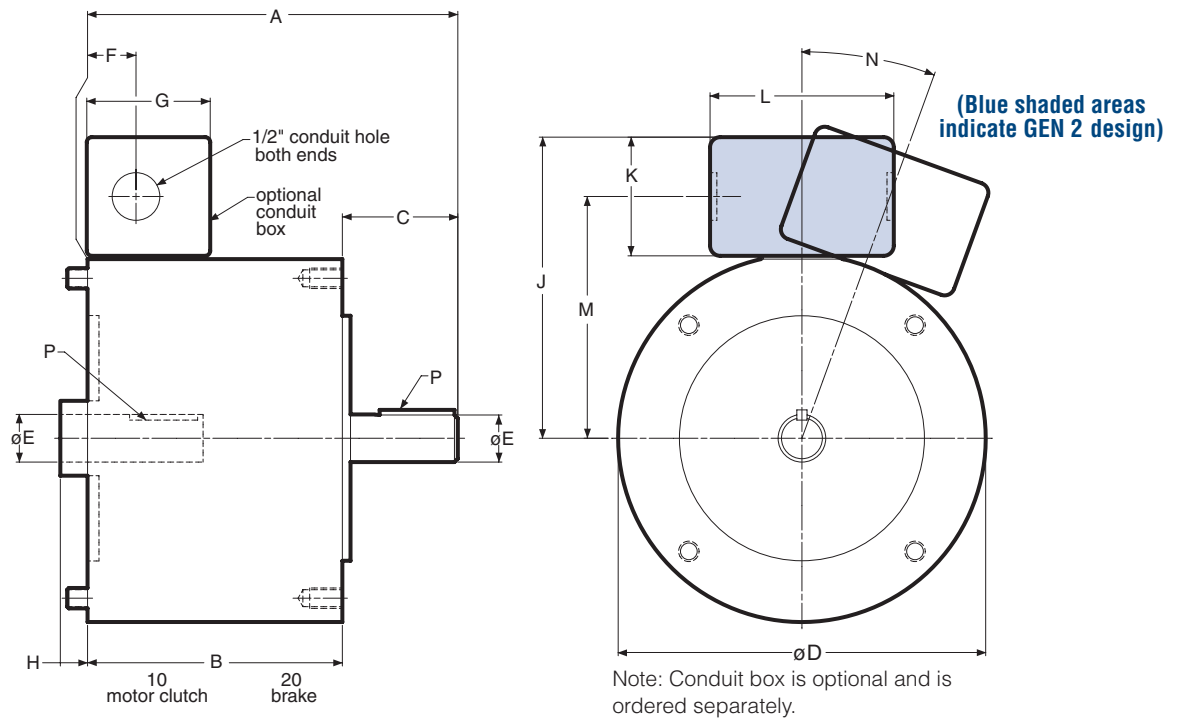

### Dimensions (Blue shaded areas indicate GEN 2 design)

Size	A	B	C	D	E	F	G	H
50	6.720	4.680	2.040	6.750	.625	.890	2.267	—
100	6.741	4.680	2.061	6.750	.625	.890	2.267	—
180	6.801	4.680	2.121	6.750	.875	.890	2.267	—
210	9.688	7.031	2.500	9.250	1.125	.500	2.267	.500
215	10.568	7.440	3.125	9.250	1.375	.500	2.267	.500

Size	J	K	L	M	N	P
50	5.516	2.180	3.250	4.426	0°	3/16 x 3/16
100	5.516	2.180	3.250	4.426	0°	3/16 x 3/16
180	5.516	2.180	3.250	4.426	0°	3/16 x 3/16
210	6.859	2.180	3.250	5.766	20°	1/4 x 1/4
215	6.859	2.180	3.250	5.766	20°	5/16 x 5/16

For standard NEMA frame dimensions, see page 64.

### Motor Mount (M) Dimensions (Blue shaded areas indicate GEN 2 design)

For use with 1020, 1040, 20, 20 FBB and 1020 FBC Combinations.

Size	R	S	T	U	V	W	Part No.
50/100	9.250	8.250	10.500	8.000	3.500	.800 x .406	5370-101-078
180	9.250	8.250	10.500	8.000	4.500	.800 x .406	5370-101-079
210/215	11.500	10.500	12.000	9.000	5.250	.750 x .409	5371-101-012

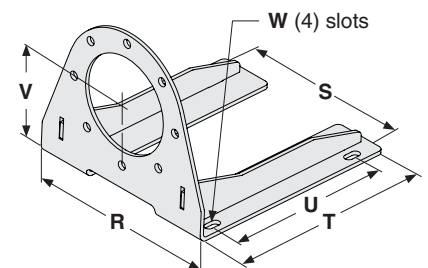

Only 50, 100, and 180 sizes of the models listed will be converted to the new GEN 2 design. 210 and 215 sizes will continue to be offered in the original design and will not be converted.