

# Sensors

## Ultrasonic Sensors



### Introduction

Ultrasonic signals are like audible sound waves, except the frequencies are much higher.

Ultrasonic transducers have piezoelectric crystals which resonate to a desired frequency and convert electric energy into acoustic energy and vice versa.

Diagram A shows how sound waves transmitted in the shape of a cone are reflected back to the transducer. At this stage, an output signal is produced to perform some kind of indicating or control function.

A minimum distance from the sensor is required to provide a time delay so that the "echoes" can be interpreted. Variables which can affect the operation of an ultrasonic sensor include: target surface angle, reflective surface roughness, change in temperature or humidity. The targets can have any kind of reflective form and even round objects are an acceptable target.

### Advantages of Ultrasonic Sensors

- Discrete distances to moving objects can be detected and measured
- Less affected by target materials and surfaces
- Not affected by color
- Solid state – virtually unlimited maintenance-free life
- Small objects can be detected over longer distances
- Resistance to external disturbances such as vibration, infrared radiation, ambient noise, and EMI radiation

### Applications for Ultrasonic Sensors

- Loop control
- Roll diameter, tension control, winding and unwind
- Web break detection
- Level detection/control
- Presence detection

### UT30 Series

The Warner Electric UT30 Series Ultrasonic Sensors feature three types of sensors:

- Range measurement with analog output
- Proximity detection with range and hysteresis control
- Long range measurement with analog output
- CE Approved

### Range Measurement with Analog Output

This type of sensor is capable of both 4–20mA and/or 0–10V output signals, with an added feature of inverting these signals to 20–4mA and for 10–0V by means of simply wiring the units in the instructed way. Long range sensors come with current (mA) output signals only.

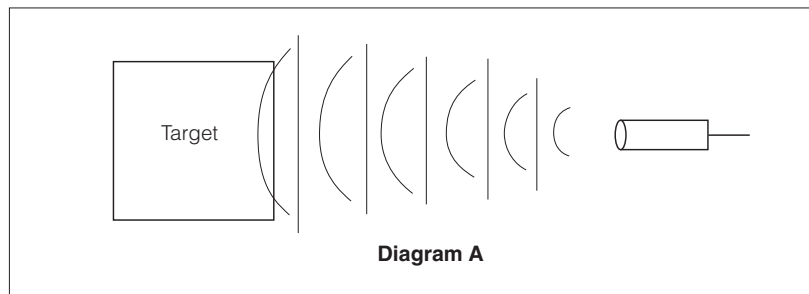

A range measurement sensor works in a very precise, easily controllable way. Precise distance of an object moving to and from the transducer is measured via time intervals between transmitted and reflected bursts of ultrasonic sound. The internal circuit reads this time and then proportionately provides an output in either MAs or volts to that distance.

### General Installation Information

#### Target Angle

This term refers to the "tilt response" limitations of a given sensor. Since ultrasonic sound waves reflect off the target/object, target angles indicate acceptable amounts of tilt for a given sensor. If an application requires a target angle beyond the capabilities of a single sensor, two sensors can be teamed to provide even a broader angle of tilt.

#### Beam Spread

This term is defined as the area in which a round wand will be sensed if passed through the target area. This is the maximum spreading of the ultrasonic sound as it leaves the transducer.



### Analog Output

- 4–20mA and 0–10V
- Wire selectable inverted or non-inverted outputs

### Specifications

<b>Sensing Range</b>	4–40" (101..1016mm)	8–80" (203..2032mm)
<b>Ordering Information</b>		
<b>Model Description</b>	UT30UP-DCA4-1016-CSI	UT30UP-DCA4-2032-CSI
<b>Part Number</b>	7600-448-001	7600-448-002
<b>Electrical Data</b>		
<b>Voltage Range</b> (min./max.)	20–30 VDC reverse polarity protected	20–30 VDC reverse polarity protected
<b>Input Current</b>	50mA	50mA
<b>Transducer Frequency</b>	212 KHz	150 KHz
<b>Short Circuit Protected</b>	Yes	Yes
<b>LED – (strength indicator)</b>	Yes – green to red; Page 152	Yes – green to red; Page 152
<b>Response Time</b>	30 mSec	50 mSec
<b>Range Control</b>	Zero and span (2 potentiometers)	Zero and span (2 potentiometers)
<b>Mechanical Data</b>		
<b>Temperature Range</b> (min./max.)	–25°F to +140°F (–31.7°C to +60°C)	–25°F to +140°F (–31.7°C to +60°C)
<b>Degree of Protection</b>	IP65/NEMA12	IP65/NEMA12
<b>Body Material</b>	Valox plastic	Valox plastic
<b>Termination</b> Cable 6 ft. (2m)	PVC 4 x 22 gauge	PVC 4 x 22 gauge
Plug/socket	Versions available to order	Versions available to order
<b>Accessories</b>	1) Brackets	1) Brackets
<b>Humidity</b>	0–95% non-condensing	0–95% non-condensing

### Dimensions

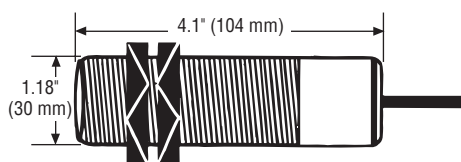

### Mounting Bracket

M 30 ST

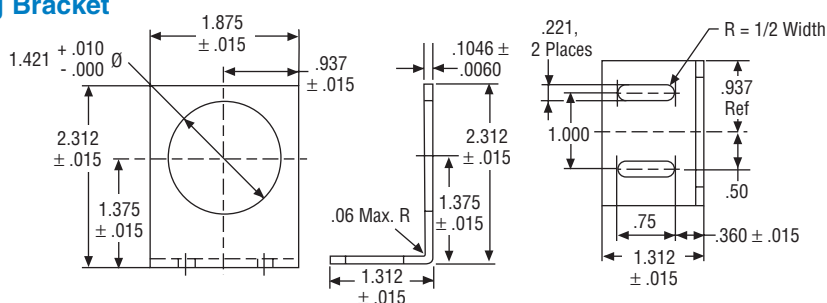

### Accessories

#### Brackets for M 30 x 1.5

#### Ordering Information

**Plastic** – BK5-D34PA  
Part Number: 596-0223-041

**Metal** – M 30 ST  
Part Number: 7430-448-003

**\*Power Supply** - NG24 110/220 VAC Input  
24 VDC @ 300mA Output  
Part Number: 7500-448-020

**Note:** Provides output to appropriate analog input control. (Ex. TCS-200-1)

### Wiring Data

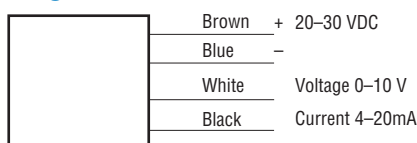

Non-Inverted Output

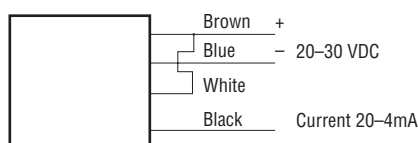

Current Output Inverted

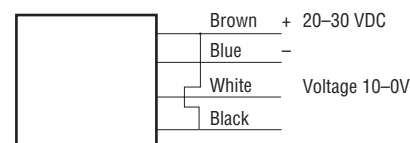

Voltage Output Inverted

**\*Note:** Some controls do not have 24 VDC outputs for the ultrasonic sensor power. These controls require the use of the NG 24 power supply

# Sensors

## Ultrasonic Sensors

### Operation and Setup

#### Minimum Analog Ranging

Minimum analog ranging is when you desire to have the full 4–20 mA or 0–10V output over the minimum 5-inch sensing span. Five inches of minimum sensing span can be adjusted anywhere in the sensing range. For example 10"–15" or 25"–30". To make this adjustment, place the target at the minimum sensing range and adjust P1 to 4mA. Then move the target to the maximum sensing range and adjust P2 to 20mA. Recheck the ratings and make appropriate adjustments, if necessary. See Diagram A.

#### Maximum Analog Ranging

Analog sensing in the maximum range means utilizing the entire 36" span (4"–40") and 72" span (8"–80"). To adjust, set the target at the minimum range, either 4" or 8", and adjust P1 to 4mA. Move the target to the maximum range and adjust P2 to 20mA. Recheck readings and make appropriate adjustments, if necessary. See Diagram B.

#### Inverted Analog Outputs

Inverted outputs means that the 4–20mA or 0–10V output signal will decrease proportionally with distance. To adjust, place the target at the minimum sensing distance and adjust P1 to 20mA. Place the target at the maximum sensing distance and adjust P2 to 4mA. Re-check readings and make appropriate adjustments, if necessary. See Diagram C.

#### LED Operation (Note D)

The LED is green when the unit is powered. It will fade to red as a target is detected with increased intensity as more signal is being reflected from the target. **Note:** Any color other than green equals a workable signal level.

#### Adjustment Pots Zero and Span Control

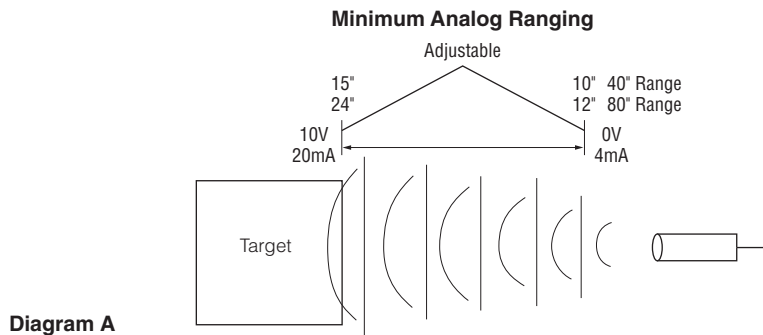
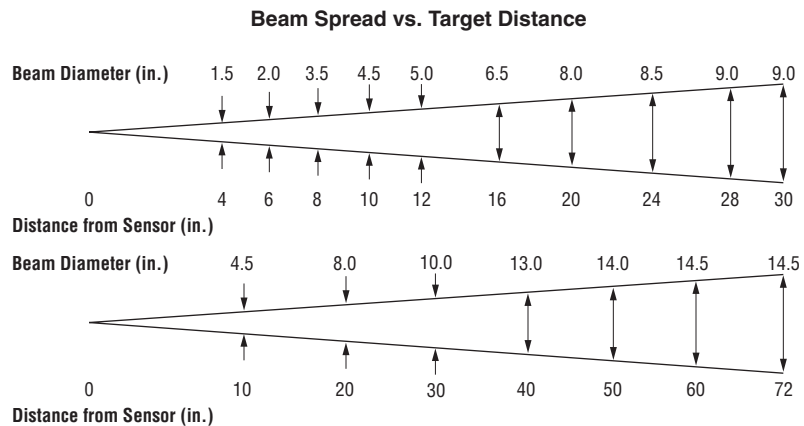
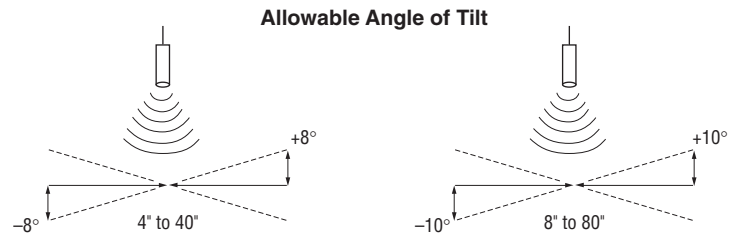
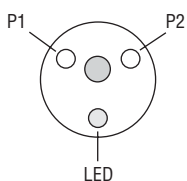

Diagram A

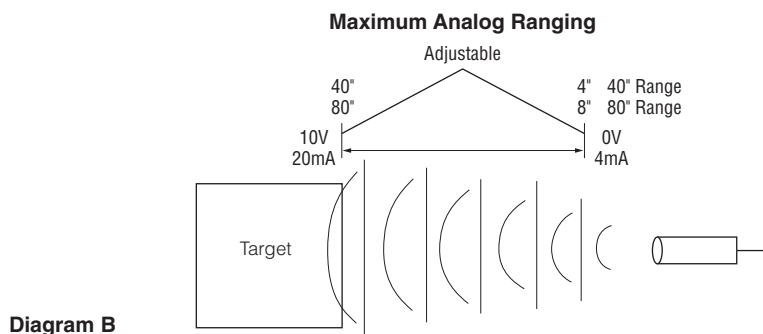

Diagram B

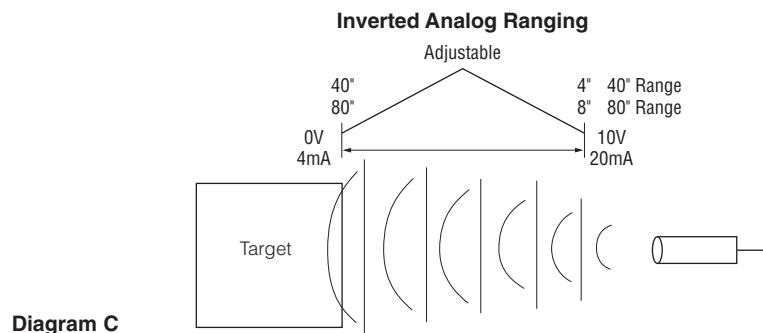

Diagram C