

Tension Control Systems

System Configurations

Technical Considerations – Tension Zones

I. A tension zone in a web processing machine is defined as that area between which the web is captured, or isolated. Virtually any machine can be broken down into tension zones, and it is important to do so to properly address maintaining the tension required.

Simple machines, such as rewinders or inspection machines, may have only one zone (see Fig. 1). The primary goal here is to control tension so that the rewrap package is accurately wound. Typically, the winder (A) would be a simple line speed motor drive, with tension controlled by a brake system at the unwind (D). The method of brake control (i.e.: open or closed loop) would be determined by the accuracy demands of the application. For simple diameter compensation, an ultrasonic sensor measuring the diameter of the roll can produce satisfactory results. Greater accuracy may require closed loop feedback, such as from a dancer or load cell.

II. More commonly, a machine will have driven nip rolls in the center, or processing section (see Fig. 2). A simple slitter/rewinder is an example. In this case, there are two separate tension zones to deal with and the tension levels may be different in each zone. Different tension levels are possible because the web is captured at the driven nip rolls, thus creating separate and distinct unwind and rewind zones. The driven nip rolls (B) will typically be powered by a motor drive that establishes machine line speed. Processing tension will be controlled by a brake system at the unwind (D), and a clutch or motor drive will control the winder tension (A). Again, the method of control will be dictated by the accuracy of tension control required in each zone. If process tension levels can vary by 10% or greater, a simple open loop brake control system may suffice. More accurate control would require a closed loop system, such as dancer or load cell feedback. Likewise, in the winder zone, open loop control may be sufficiently accurate, or closed loop or taper tension control may be required.

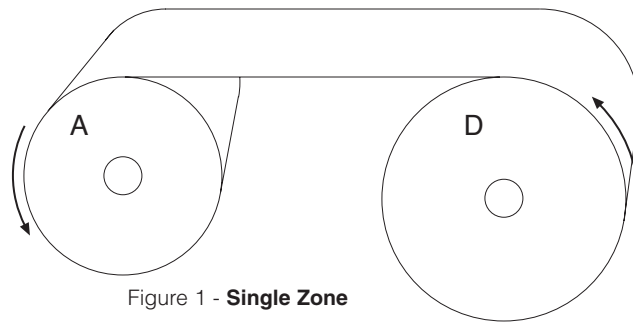

Figure 1 - Single Zone

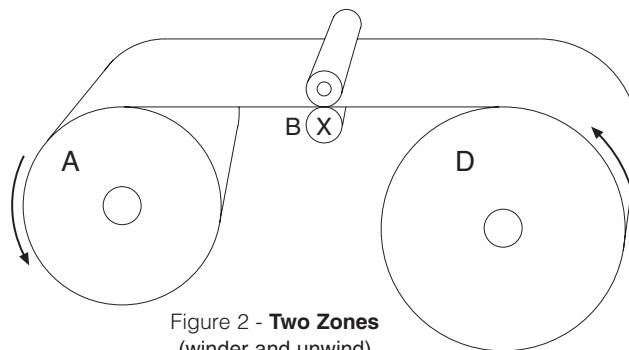

Figure 2 - Two Zones (winder and unwind)

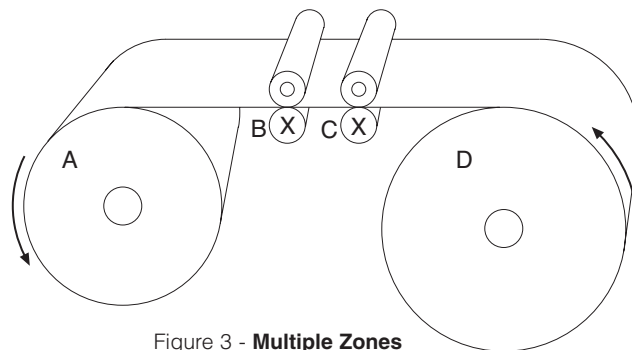

Figure 3 - Multiple Zones (winder, intermediate, unwind)

III. More complex machines will usually have multiple intermediate zones in addition to the unwind and rewind zones (see Fig. 3). One of the intermediate zone drives will typically establish line speed, and the control of drive rolls for the other zones will relate to this drive. In some instances, a simple master/slave relationship with a speed differential ratio will provide the draw tension necessary in that zone (i.e. Fig. 3 – B & C). In other cases, this may be

accomplished with closed loop (dancer or load cell) trim. The rewind (A) and unwind (D) would be handled as described in II. Multiple intermediate zones can become very complex, particularly if high degrees of accuracy are required. As a general rule of thumb, control of any zone should be accomplished at one end of the zone only. Control systems at both ends of the zone (for that zone) will generally result in instability of tension levels.

Reliable and accurate control for all system design layouts

Open loop tension control systems provide the least expensive manner to provide a degree of web tension control with the minimal amount of components. Open loop tension control can apply to unwind, intermediate, or rewind tension applications.

Although not as sophisticated as most closed loop tension control systems, a degree of controllability is achieved. Using open loop tension systems, one does sacrifice such things as web storage for acceleration, deceleration, and E-stop conditions. Tension variations during machine start or stop are common with this type of system.

The most common of the various tension systems are generally comprised of the controlled device; i.e., brake, clutch, etc., a simple controller or power supply, and a controlling element, i.e., a potentiometer or some type of analog sensor.

Because of system simplicity, tension is maintained for diameter compensation only in an unwind or rewind system, and no compensation is provided for acceleration, deceleration, E-stop or out of round roll conditions. Tension variations of 25% or more may

Open Loop System

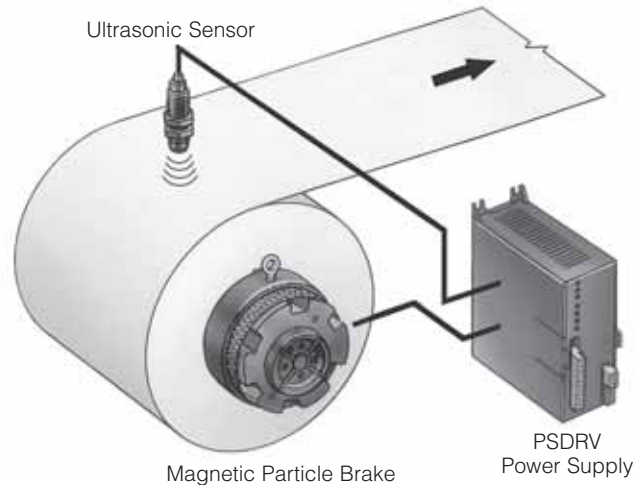

be possible during acceleration or deceleration, and 10% or more during running due to out of round rolls or variations in the process machines.

These types of systems lend themselves nicely to applications where tension variations are not a concern, and hold back on a rewind role or scrap

wind up is needed. Operator adjustments are usually required when material tensions or roll diameters are changed initially.

Typical Components

For the simplest of unwind systems, the following components might be used:

- Tension brake coupled to the unwind roll, i.e., ATTB, TB, magnetic particle, or MTB, or pneumatic brake
- Tension controller to provide control current or voltage to the brake, i.e., TCS-200-1, MCS-166/MCS-204, TCS-167/TCS-220, MCS-166/MCS-208
- Control, either the manually adjusted type with a control potentiometer, or through an external potentiometer coupled to a follower arm, or ultrasonic or analog proximity sensor monitoring roll diameter.

Flying Splicer

Specially designed solid state splicer control holds the unused roll stationary while tensioning the operating roll. Dancer variation sensing and subsequent adjustment are virtually instantaneous for accurate tensioning during the splice, typically at less than 1% variation.



Tension Control Systems

System Configurations

Closed Loop System

Closed loop tension systems provide very precise and accurate tension control during steady state running conditions as well as acceleration, deceleration, and E-stop conditions. Because the material web is monitored constantly, either by load cells or from a dancer by position, changes are detected immediately and the controlled device is changed instantaneously to maintain accurate tension control.

The two most common methods of providing closed loop tension control are via load cells that monitor the force on the web directly or via dancers, which provide tension by the load imposed by the dancer roll and dancer position and velocity are monitored, usually by a precision potentiometer. Even the most minute changes are sensed and compensated for in a closed loop system.

Closed loop tension control systems require the least amount of operator involvement during running. Normally, the operator sets only the tension level required for the material being run, once the system has been properly set up and adjusted. Closed loop system controllers compensate for changes in roll diameter and conditions, acceleration, deceleration, and machine variations.

Although closed loop tension control systems offer the most advantageous method of providing web tension control, be it dancer or load cell, there are some limitations to each type of system. In dancer systems, more space is required in the machine to accommodate the dancer arm and rollers, and some method, preferably an air cylinder and regulator, is required for loading. Load cell systems, on the other hand, require less space for mounting, but storage is non-existent for acceleration or deceleration, and balancing of all machine rollers. Web contact is required because of load cells' high sensitivity.

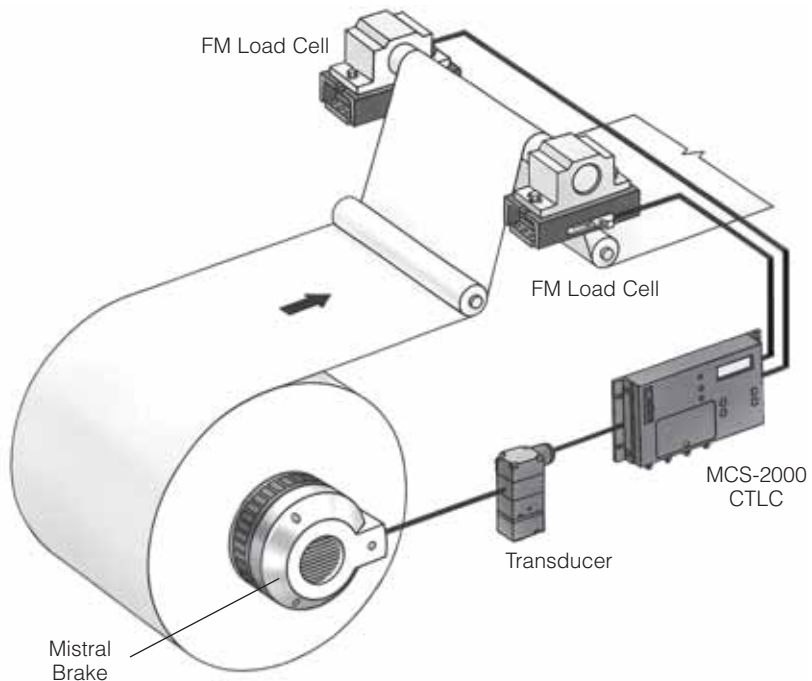

Typical System Components

The typical components of a closed loop tension system are:

- Tension brake coupled to the unwind roll; i.e., TB, MTB, magnetic particle, pneumatic brake
- Controller to provide proper signal to control device; i.e., MCS2000EAC/

MCS2000PSDRV, MCS-166/MCS-203, TCS-167/TCS-210, MCS-166/MCS-207

- Controlling element, either load cell or dancer pivot point sensor potentiometer

In general, closed loop tension control is the preferred method in more complex machines where precise tension control is required due to process requirements, such as precise registration, multiple color printing or coating to an exact thickness.

Slitter/Rewinder

Slitter/rewinders process an unlimited number of materials including paper, wires, and foils. Modularity and broad torque capability make Warner Electric the ideal system for the complete range of slitter/rewinder tensioning requirements.

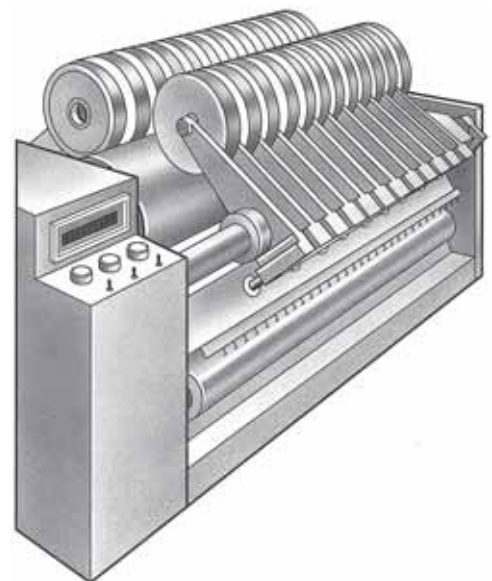

Dual Output and Splicer System

Dual output tension control systems, often referred to as splicer controls, offer the user a multitude of options for the way they may be set up and used. Dual output tension controls have the capability of operating both outputs simultaneously from a single input or operating each output alternately, one being controlled by the sensing input and the other in a holding mode. This allows the controls to be used on either zero speed or flying splicers.

Control types include both analog, such as the TCS-310 dancer control and the TCS-320 remote/analog controller, and digital such as the MCS2000 ECA. Dual output controllers work like the single output controllers, except a few more features are included to provide switching between the output channels when operated as splicer controls.

The remote/analog splicer control provides an output proportional to the input. Typically, this is an open loop controller and does not compensate for acceleration, deceleration, or E-stops in the system. In addition, it provides no compensation for out of round roll conditions or variations associated with machine functions. This is the most basic type of controller and, in many cases, requires operator intervention to compensate for changing roll conditions.

The dancer splicer control, TCS-310, has additional features to provide automatic compensation for acceleration, deceleration, E-stop, out of round roll conditions and variations in the machine functions. A three-term control loop (P-I-D) is used to provide these functions. Set-up adjustments are provided to tune the system for optimum performance and, once set, requires no additional adjustment. With the dancer splicer system, operator involvement during

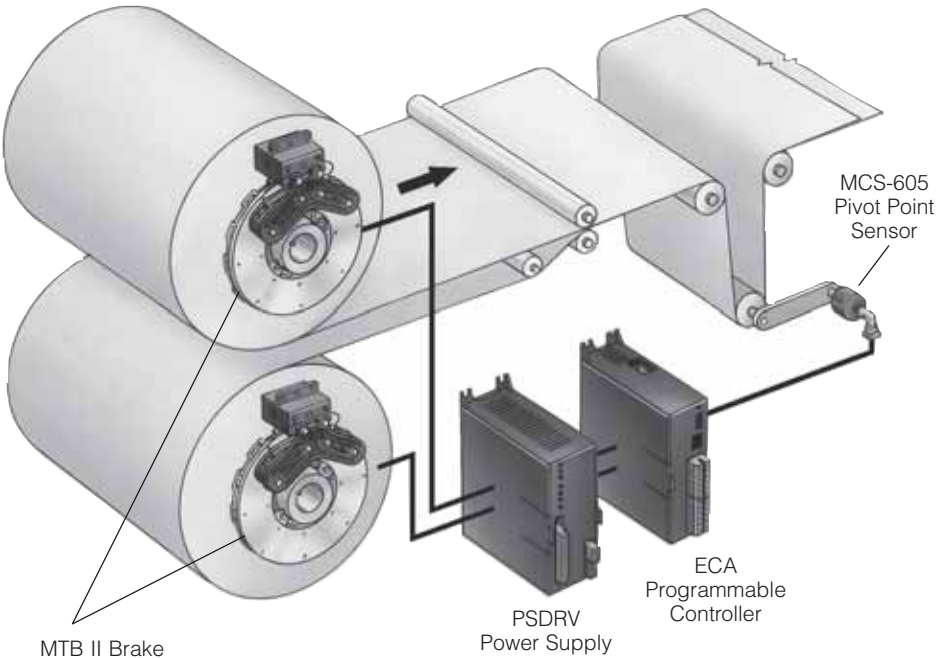

a run is eliminated, and precise tension control is achieved.

The digital tension controller, MCS2000 ECA, allows the user a multitude of functions for both the type of inputs being used and the outputs for the controlled element. Because of its modularity, the user can tailor the MCS2000 system to specific application requirements. This system can be used as an open loop controller being controlled by a manual potentiometer, a roll follower pot, or some type of analog input sensor, i.e., ultrasonic or photoelectric.

The same controller can also be used with either a dancer or load cell

and an optional input module for closed loop control. By changing the parameters, this is easily accomplished without having to change to a different control.

Depending on application requirements and the control selected, the optimum system for machine function and control can be selected.

Tension Control Systems

System Configurations

Typical Components for Splicer System

For Modular MTB Brakes Only

- Modular tension brake, MTB Series.
- Dual output tension controller, i.e., TCS-310 for dancer system, TCS-320 for remote/analog system, for providing current to brake magnets.
- Power supply, TCS-168, to provide control and brake power.
- Controlling element, i.e., pivot point sensor for dancer system; external pot, remote signal, or analog sensor for remote/analog controller.

For other Brake/Clutch Systems

- Tension brake, clutch, or electronic motor drive, i.e., TB's, MTB's, ATT's, magnetic particles or pneumatic.
- Tension controllers, MCS2000 ECA and appropriate output modules and/or input modules as necessary depending on system type.
- Control element, i.e., dancer potentiometer, load cells, tachometers, or analog sensors, depending on application requirements.

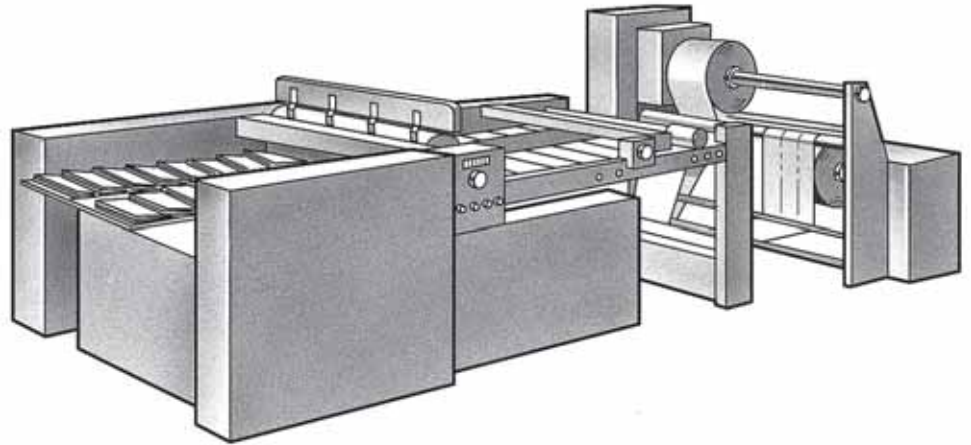

Bag Making Machines

The smooth, consistent tension provided by Warner Electric tension control systems eliminates most reject bags caused by uneven reel tension. On preprinted bags, Warner Electric tension brakes and control systems allow superior registration control to keep the printed area in its optimum position.

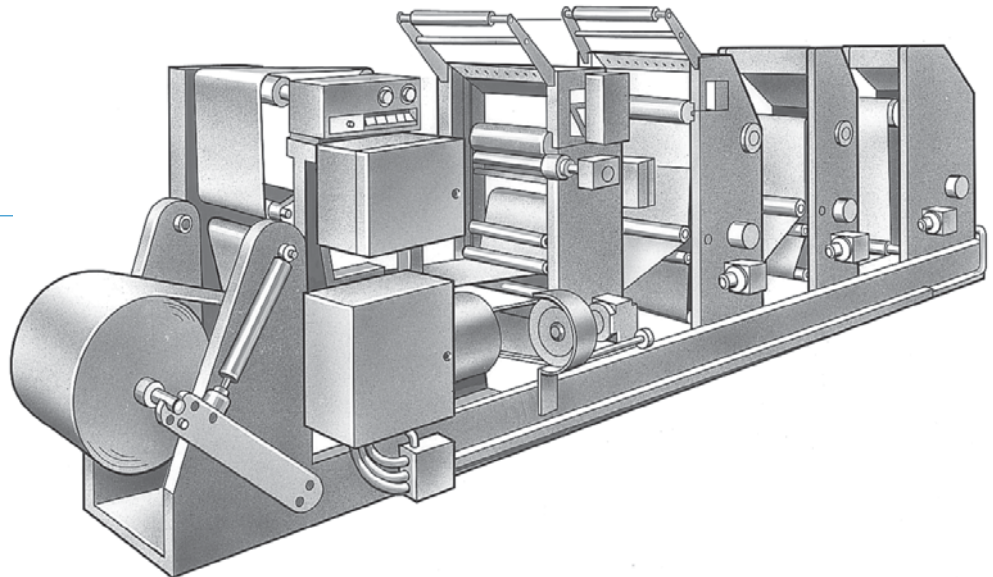

Business Forms Press

Unique control circuitry allows Warner Electric tensioning systems to maintain exact web tension for intermittent web processing operations. From the beginning of each roll to its core, operator adjustment is unnecessary, even at the highest production speeds.