

Individual Clutch or Brake Module Combine to Comprise a Clutch, Brake or Clutch/Brake Combination!

Electro Modules are individual clutch or brake units which are assembled together to comprise a clutch, brake, or clutch/brake combination. Electro Modules can be bolted directly to a NEMA C-face motor or reducer or they can be base mounted for stand alone operation. Electro Modules offer the ultimate in clutch/brake convenience. They are easy and quick to install and require no lubrication or maintenance for life.

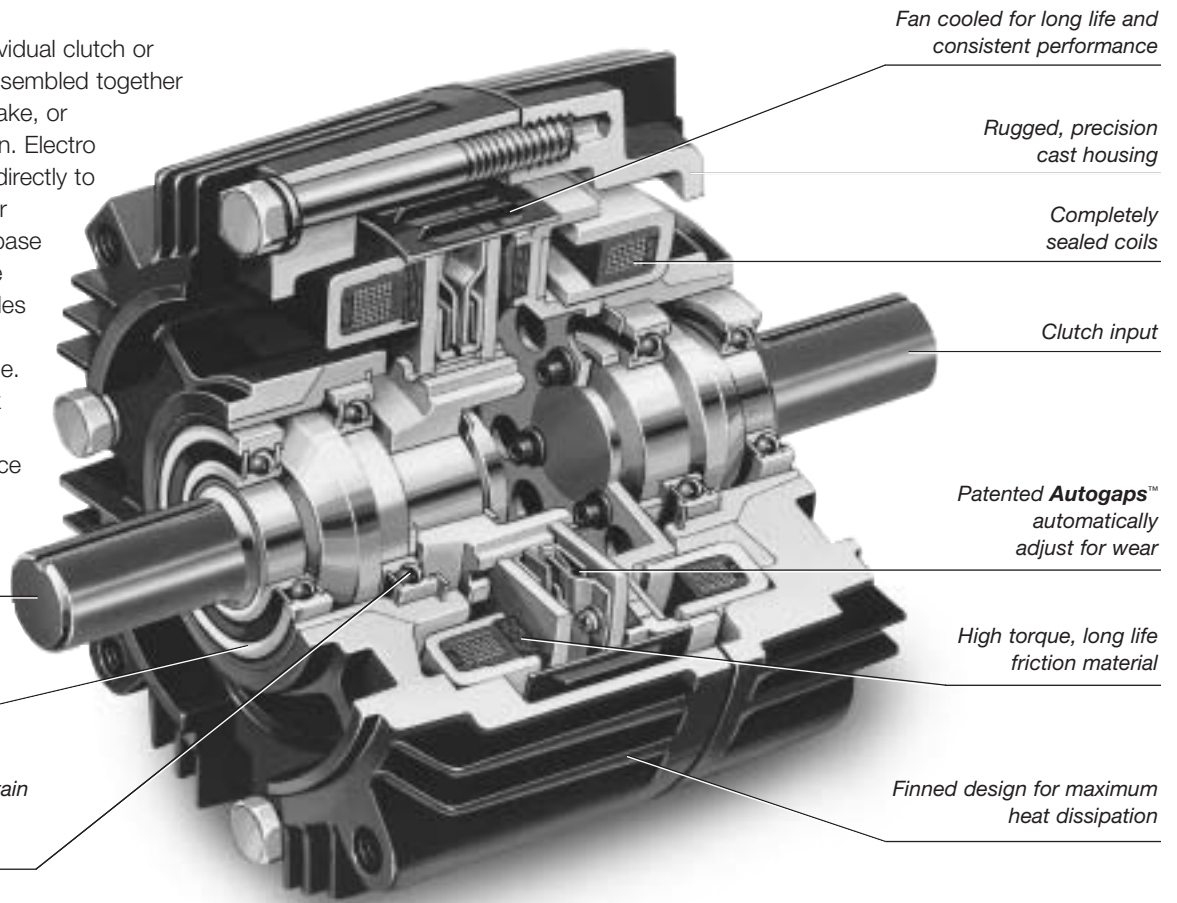

Brake output

NEMA C-face compatible design

Heavy duty bearings maintain tight concentricities and running efficiency

Fan cooled for long life and consistent performance

Rugged, precision cast housing

Completely sealed coils

Clutch input

Patented **Autogaps™** automatically adjust for wear

High torque, long life friction material

Finned design for maximum heat dissipation

Bolt-it-down and wire-it-up . . . it's ready to go!

- Modular design flexibility
- 1/4 to 7-1/2 HP at 1800 RPM
- Outstanding controllability
- Fast cycling
- Smooth starts and stops
- Accurate
- Bidirectional
- Consistent performance
- Complete control capability

Selection Flexibility Clutch/Brake Combination

A wide range of module combinations for use with motors, reducers and other standard power transmission components is available. The flexibility of Electro Module enables you to pick the exact combination of function and design.

Power-On Applications

Electro Modules for power-on applications are purchased as individual clutches and brakes to be assembled for C-face, flange, or base mounting applications.

Power-Off (Electrically Released) Applications

Electrically released operation is the primary feature of power-off Electro Module brakes. They can be used as brakes, motor brakes and in combination with clutches. See pages 114, 116 and 123 for complete information.

Selection

The correct size can be determined from easy-to-use selection charts based on NEMA frame sizes or horsepower and shaft speed. Examples show the right way to order the Electro Module required.

Controls

Warner Electric controls assure that you get the maximum performance from your Electro Module. See the Controls Section for all the models.

Clutch Modules

10 Motor Clutch

Fan cooled for long life and consistent performance.

See page 14.



30 Input Clutch

Fan cooled. Sealed coils. Twin bearing mounted shaft maintains tight concentricities.

See page 16.



40 Output Clutch

Autogaps™ automatically for wear. Does not have a –use in combination with 30 Input Clutch

See page 17.



Brake Modules



20 Brake

Bolts directly to C-face components. See page 15.

20-FBB Electrically Released Brake

Use for brake alone applications. Has one armature. See page 134.

20-FBC Electrically Released Brake

Use in combination with a 10 Motor Clutch or 30 Input Clutch module. Has dual armatures. See page 135.



20MB Motor Brake

Does not have a shaft. Has end cap. See page 15.

20MBFB Electrically Released Motor Brake

Automatically engages when power goes off. Requires no power to stop or hold a load. See page 136.

Clutch Combinations



10/40

Motor Clutch/Output Clutch

Use for clutch only applications. Has hollow bore input for mounting directly to C-face motors. Shaft and C-face on output side of unit accommodates reducer, parallel drive or coupling. Basic components are field, rotor and armature. See page 19.



30/40

Input Clutch/Output Clutch

Use for clutch only applications. Features dual C-faces and shafts. Unit input from parallel drive or coupling. Output to reducer. Basic components are field, rotor and armature. See page 21.



30/40-B

Input Clutch/Output Clutch-Base Mounted

Base mounting allows the clutch units to be utilized as a separate drive unit. Attach with pulleys, sprockets, etc. See page 21.

Clutch/Brake Combinations



10/20

Motor Clutch/Brake

Use for clutch/brake applications. Hollow bore input. Shaft on output side. Basic components are field, rotor, 2 armatures and power-on magnet. See page 18.

10/20-FBC

Motor Clutch/Electrically Released Brake

Use for clutch/electrically released brake applications. Basic components are field, rotor, 2 armatures and power-off magnet. See page 135.



20/30

Brake/Input Clutch

Use for clutch/brake applications. Features dual C-faces and shafts. Input from parallel drive or coupling. Output to reducer. Basic components are field, rotor, 2 armatures and power-on magnet. See page 20.

20/30-FBC

Electrically Released Brake/Input Clutch

Use for clutch/electrically released brake applications. Basic components are field, rotor, 2 armatures and power-off magnet. See page 122.



20/30-B

Brake/Input Clutch-Base Mounted

Stand alone units attach with pulleys, sprockets, etc. See page 20.

20/30-FBC-B

Electrically Released Brake/Input Clutch-Base Mounted

Stand alone units attach with pulleys, sprockets, etc. See page 122.

Selection

Electro Module clutch or brake units may be mounted directly to NEMA C-face motors and reducers, or can be base mounted.

1. Select Configuration

a. NEMA C-face Mounting

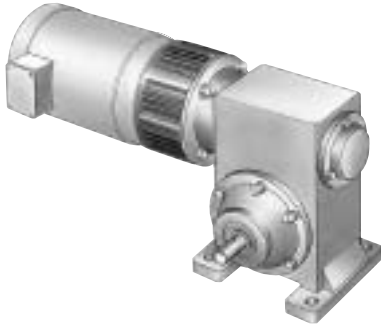

Based on the NEMA C-face frame size of the prime mover, select the correct clutch or brake module size from the Frame Size Selection chart. Size 100 houses the components of the size 180 in a size 50 frame, while size 215 incorporates size 210 components.

b. Base Mounting

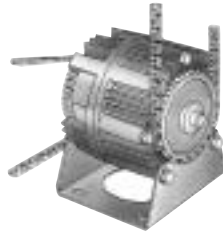

Electro Module assemblies may be mounted as separate drive units driven from the prime mover by V-belts, chain and sprockets, couplings, timing belts and other standard power transmission components.

Select the correct size module from the Horsepower vs. Shaft Speed chart by determining the motor horsepower and RPM at the module location. The correct size Electro Module is shown at the intersection of the HP and operating speed.

For additional sizing information, refer to the technical sizing procedure (step 2).

2. Determine Technical Requirements

Technical considerations for sizing and selection are torque and heat dissipation. Each merits careful consideration, especially heat dissipation as over time, use in excessive temperature environments will have an adverse effect on bearing life and coil wire insulation integrity.

Compare the calculated torque requirement with the average dynamic torque ratings. Select a unit with adequate torque. If the unit selected on torque is different than the unit selected based on heat, select the larger size unit.

Frame Size Selection

NEMA Frame Size	Electro Module Size
56C/48Y	EM-50* EM-100**
182C/143TC 184C/145TC	EM-180
213C/182TC 215C/184TC	EM-210
213TC/215TC	EM-215

*For 56C/48Y C-frame motors 3/4 HP and smaller, the EM-100 size may be used where extended life is desirable.

**The EM-100 size is recommended for motors 1 HP and larger.

Horsepower vs. Shaft Speed

HP	SHAFT SPEED AT CLUTCH (IN RPM)																
	100	200	300	400	500	600	700	800	900	1000	1100	1200	1500	1800	2000	2400	3000
1/4	EM-50																
1/2																	
3/4	EM-100 or EM-180																
1																	
1-1/2	EM-210 or EM-215																
2																	
3																	
5																	
7-1/2																	

a. Heat Dissipation Sizing

Friction surfaces slip during the initial period of engagement and, as a result, heat is generated. The clutch/brake selected must have a heat dissipation rating greater than the heat generated by the application. Therefore, in high inertia or high cycle rate applications, it is necessary to check the heat dissipation carefully. Inertia, speed and cycle rate are the required parameters.

Heat dissipation requirement is calculated as follows:

$$E = 1.7 \times WR^2 \times (N/100)^2 \times F$$

where:

$$E = \text{Heat (lb. ft./min.)}$$

WR^2 = Total reflected inertia at the clutch/brake shaft. Include the clutch/brake output inertia. (lb.ft.²)

N = Speed in revolutions per minute. (RPM)

F = Cycle rate in cycles per minute (CPM)

Compare the calculated heat generated in the application to the unit ratings using the heat dissipation curves. Select the appropriate unit that has adequate heat dissipation ability.

Heat Dissipation Curves

Size 50

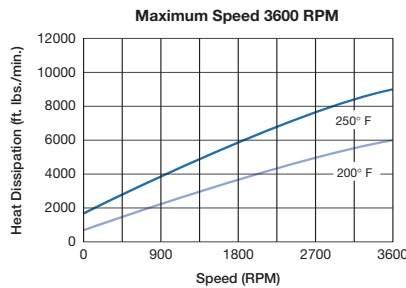

Size 100/180

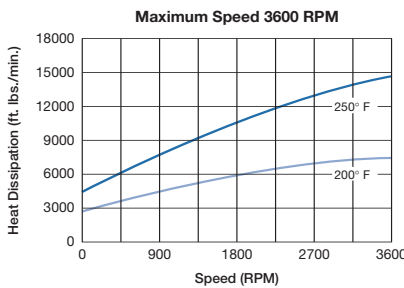

Size 210/215

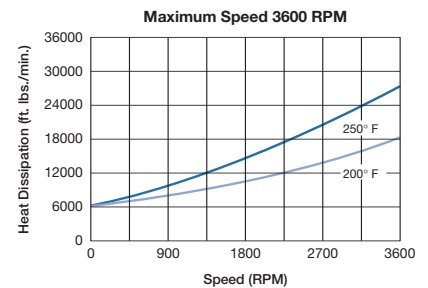

b. Torque Sizing

For most applications, the correct size clutch/brake can be selected from the Horsepower vs. Shaft Speed chart.

Determine the motor horsepower and the RPM at the clutch/brake. The correct size unit is shown at the intersection of horsepower and shaft speed.

If the static torque requirements are known, refer to the Specifications Table to select a unit.

For some applications, the torque requirement is determined by the time allowed to accelerate and decelerate the load. (This time is generally specified in milliseconds.) For these applications, it is necessary to determine the torque requirement based on load inertia and the time allowed for engagement.

The torque requirements are calculated as follows:

$$T = (WR^2 \times N) / (308 \times t)$$

where:

$$T = \text{Average Dynamic Torque (lb. ft.)}$$

WR^2 = Total reflected inertia at the clutch/brake shaft. Include the clutch/brake output inertia. (lb. ft.²)

N = Speed in revolutions per minute. (RPM)

t = Time allowed for the engagement (sec)

C-face Clutch/Power-on Brake Dynamic Torque Curves

Size 50

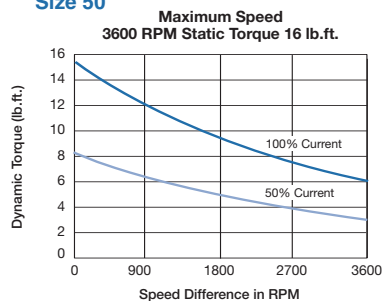

Size 100/180

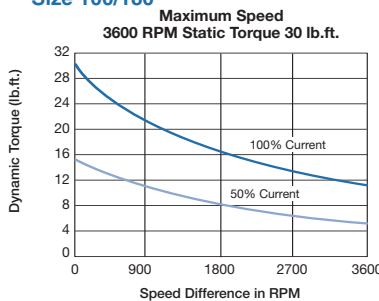

Size 210/215

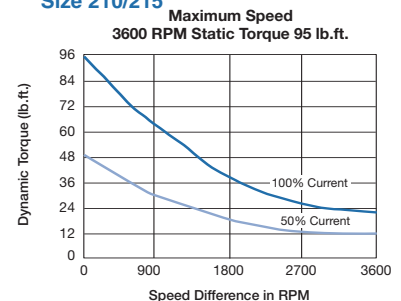

Specifications

EM Size	Static Torque lb. ft.	Maximum RPM	Voltage D.C.
50	16	3600	6, 24, or 90
100	30	3600	6, 24, or 90
180	30	3600	6, 24, or 90
210	95	3600	6, 24, or 90
215	95	3600	90

3. Accessories

Warner Electric Electro Modules can be fitted with several accessories to extend their capacity and ease of mounting.

a. Conduit Box

NEMA 4 and UL listed, available in standard and washdown versions.



a. Mounting Brackets

Two styles of mounting brackets are available for simplified installation. The base mount is used with the 20/30 and 30/40 configurations. A motor mount is also available and provides sturdy support for 10/20 and 10/40 units and motor.



4. Select Control

Warner Electric manufactures clutch/brake controls to meet several system functions including:

- On/Off
- Torque adjust
- Over excitation
- Position loop

Many requirements beyond function can impact control selection. See the Controls Section on page 141 for complete information.

Part Numbers

Description	Model No.	Voltage DC	Part No.	
10 Motor Clutch Module	EM-50-10	6	5370-270-020	
	EM-50-10	24	5370-270-030	
	EM-50-10	90	5370-270-015	
	EM-100-10	6	5370-270-045	
	EM-100-10	24	5370-270-056	
	EM-100-10	90	5370-270-046	
	EM-180-10	6	5370-270-021	
	EM-180-10	24	5370-270-055	
	EM-180-10	90	5370-270-017	
	EM-210-10	6	5371-270-011	
EM-210-10	24	5371-270-027		
EM-210-10	90	5371-270-009		
20 Brake Module	EM-50-20	6	5370-169-043	
	EM-50-20	24	5370-169-045	
	EM-50-20	90	5370-169-042	
	EM-100-20	6	5370-169-040	
	EM-100-20	24	5370-169-072	
	EM-100-20	90	5370-169-041	
	EM-180-20	6	5370-169-050	
	EM-180-20	24	5370-169-071	
	EM-180-20	90	5370-169-051	
	EM-210-20	6	5371-169-022	
EM-210-20	24	5371-169-034		
EM-210-20	90	5371-169-023		
EM-215-20	90	5371-169-076		
20MB Motor Brake	EM-50-20MB	6	5370-169-047	
	EM-50-20MB	24	5370-169-062	
	EM-50-20MB	90	5370-169-048	
	EM-180-20MB	6	5370-169-053	
	EM-180-20MB	24	5370-169-073	
	EM-180-20MB	90	5370-169-054	
EM-210-20MB	EM-210-20MB	6	5371-169-025	
	EM-210-20MB	24	5371-169-035	
	EM-210-20MB	90	5371-169-026	
	30 Input Clutch Module	EM-50-30	6	5370-270-019
		EM-50-30	24	5370-270-052
		EM-50-30	90	5370-270-016
EM-100-30		6	5370-270-047	
EM-100-30		24	5370-270-054	
EM-100-30		90	5370-270-048	
EM-180-30	EM-180-30	6	5370-270-049	
	EM-180-30	24	5370-270-053	
	EM-180-30	90	5370-270-050	
	EM-210-30	6	5371-270-023	
	EM-210-30	24	5371-270-026	
	EM-210-30	90	5371-270-024	
40 Output Clutch Module	EM-50-40		5370-536-008	
	EM-100-40		5370-536-007	
	EM-180-40		5370-536-009	
	EM-210-40		5371-536-005	

Accessories

Description	EM Size	Part No.
Conduit Box	EM series	5370-101-042
	All sizes	
Base Mount Kit for 2030, 3040	50/100	5370-101-004
	180	5370-101-002
	210/215	5371-101-001
Motor Mount Kit for 20, 1020, 1040	50/100	5370-101-010
	180	5370-101-012
	210/215	5371-101-012

How to Order

Motor or Reducer Mounted

Simply combine the size number with the configuration of the modular combination from page 9.

Specify voltage and whether 20 brake module is power-on (20) or electrically released (20FBB). See chart for specific part numbers. See pages 130-133 for electrically released models. Order optional conduit box if desired.

Example

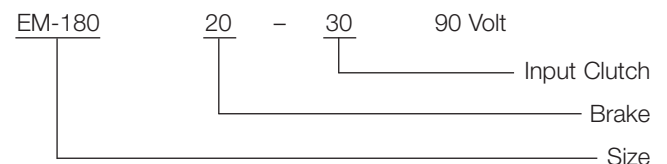

Base Mounted

Simply combine the size number with the configuration of the modular combination from page 9.

Specify voltage and whether 20 brake module is power-on (20) or electrically released (20FBB). See chart for specific part numbers. Order optional conduit box if desired.

Example

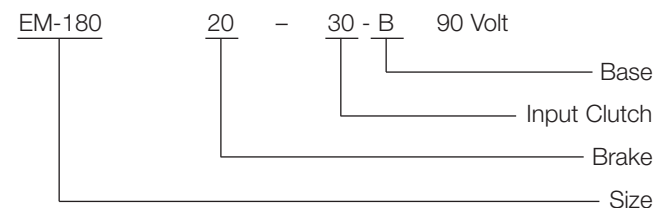

Select Appropriate Power Supply/Control. See the Controls Section beginning on page 141.

10 Motor Clutch Module

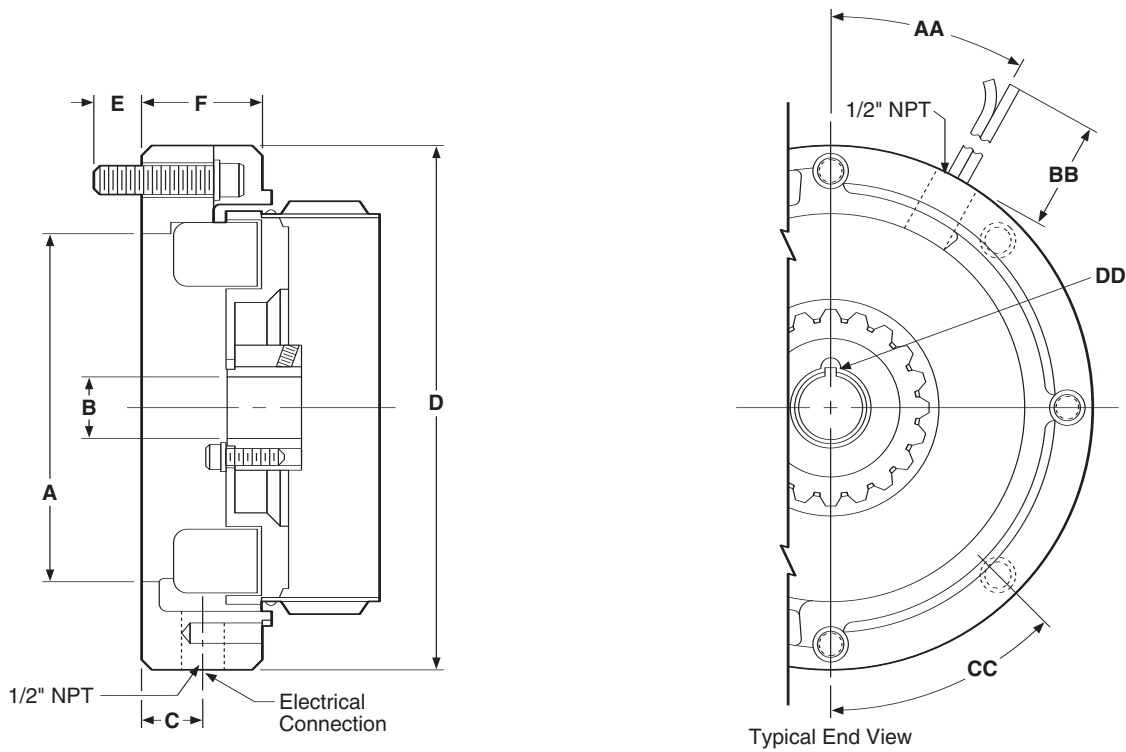

All dimensions are nominal, unless otherwise noted.

Size	A Pilot Dia.	B Dia.	C	D Dia.	E Max.	F Max.	AA	BB Min.	CC	DD Key
50	4.500	.625	.813	6.750	.599	1.563	30°	36	45°	3/16 x 3/16
100	4.500	.625	.813	6.750	.599	1.563	30°	36	45°	3/16 x 3/16
180	4.500	.875	.813	6.750	.599	1.563	30°	36	45°	3/16 x 3/16
210	8.500	1.125	.703	9.250	.625	1.313	25°	36	45°	1/4 x 1/4

Specifications

Model Size	Voltage DC	Static Torque lb. ft.	Max. RPM	Inertia-WR ² (lb.ft. ²)	Weight (lbs)	NEMA Frame Size
50	6, 24, 90	16	3600	.020	3.4	56C/48Y*
100	6, 24, 90	30	3600	.046	5.1	56C/48Y**
180	6, 24, 90	30	3600	.046	5.1	182C/143TC 184C/145TC
210	6, 24, 90	95	3600	.188	9.1	213C/182TC 215C/184TC

* For 56C/48Y Frame motors 3/4 HP and smaller the EM-100 size may be used where extended life is desirable.

** EM-100 size is recommended for motors 1 HP and larger.

For NEMA Standard frame sizes, see page 137.

20 Brake Module 20MB Brake Module

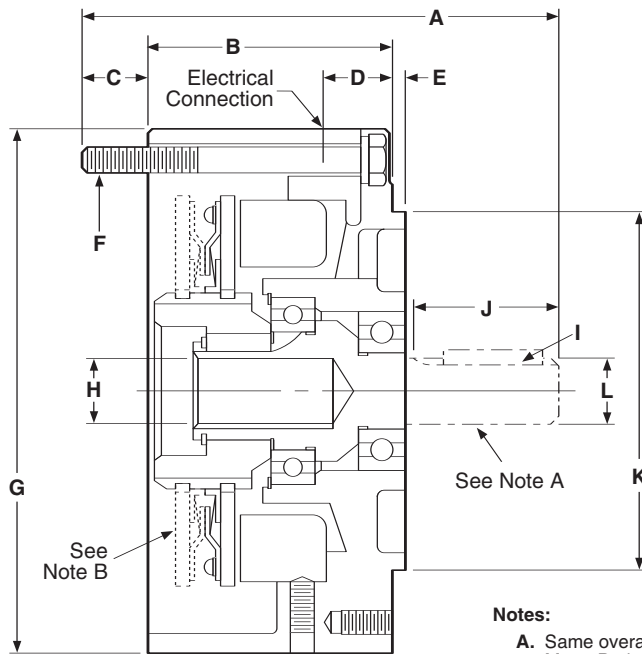

Notes:

- A. Same overall dimensions apply to Motor Brakes. 20MB Module does not have an output shaft.
- B. Clutch armature only applies to EM-20.

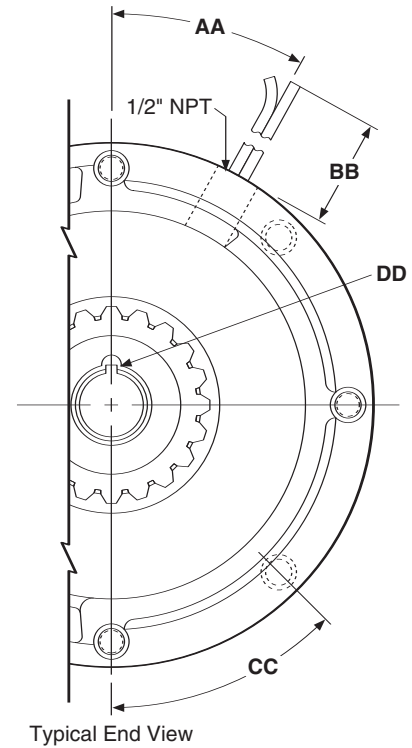

All dimensions are nominal, unless otherwise noted.

Size	A Max.	B	C Max.	D	E Max.	F	G Dia.	H Dia.	I Keyway	J Min.	K Pilot Dia.	L Dia.	AA	BB Min.	CC	DD Key
50	5.188	3.125	.500	1.000	.156	3/8-16 UNC-2A Equally Spaced (4) on 5.875 D.	6.688	.625	3/16 X 3/16 x 1-3/8	1.813	4.500	.625	30°	36	45°	3/16 x 3/16
100	5.188	3.125	.500	1.000	.156	3/8-16 UNC-2A Equally Spaced (4) on 5.875 D.	6.688	.625	3/16 X 3/16 x 1-3/8	1.813	4.500	.625	30°	36	45°	3/16 x 3/16
180	5.266	3.125	.500	1.000	.156	3/8-16 UNC-2A Equally Spaced (4) on 5.875 D.	6.688	.875	3/16 X 3/16 x 1-3/8	1.891	4.500	.875	30°	36	45°	3/16 x 3/16
210	7.578	4.609	.594	1.500	.313	1/2-16 UNC-2A Equally Spaced (4) on 7.250 D.	9.344	1.125	1/4 X 1/4 x 2	2.500	8.500	1.125	25°	36	45°	1/4 x 1/4
215	8.078	4.609	.594	1.500	.313	1/2-16 UNC-2A Equally Spaced (4) on 7.250 D.	9.344	1.375	1/4 X 1/4 x 2	3.000	8.500	1.375	25°	36	45°	5/16 x 5/16

Specifications

Model Size	Voltage DC	Static Torque lb. ft.	Max. RPM	Armatures	Inertia-WR ² Arm. Hub	Shaft	Weight (lbs)	NEMA Frame Size
50	6, 24, 90	16	3600	.014	.002	.001	6.6	56C/48Y*
100	6, 24, 90	30	3600	.036	.003	.002	8.1	56C/48Y**
180	6, 24, 90	30	3600	.036	.003	.002	8.1	182C/143TC 184C/145TC
210	6, 24, 90	95	3600	.162	.021	.017	21.5	213C/182TC 215C/184TC
215	90	95	3600	.162	.021	.019	22	213TC/215TC***

* For 56C/48Y Frame motors 3/4 HP and smaller the EM-100 size may be used where extended life is desirable.

** EM-100 size is recommended for motors 1 HP and larger.

*** For 7-1/2 HP max.

For NEMA standard frame sizes, see page 137.

30 Input Clutch Module

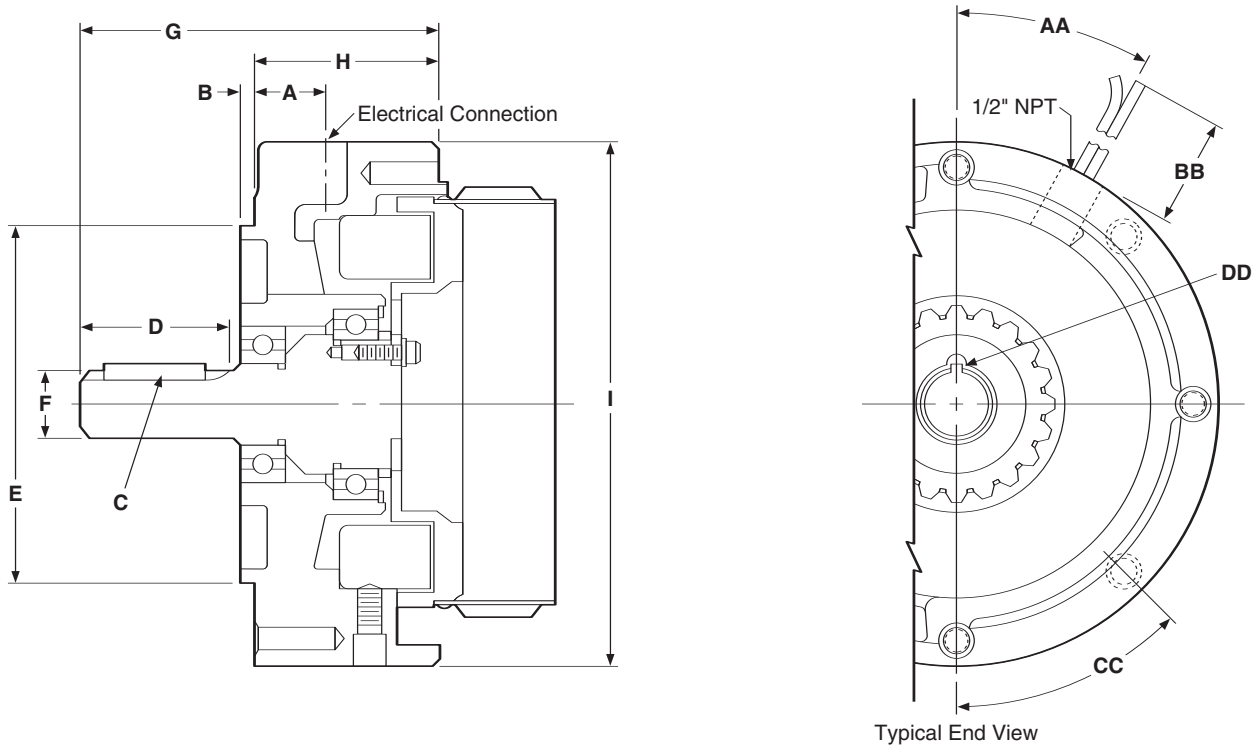

All dimensions are nominal, unless otherwise noted.

Size	A	B Max.	C	D Min.	E Pilot Dia.	F Dia.	G Max.	H	I Dia.	AA	BB Min.	CC	DD Key
50	1.000	1.56	3/16 x 3/16 x 1-3/8	1.813	4.500	.625	4.328	2.266	6.688	30°	36	45°	3/16 x 3/16
100	1.000	1.56	3/16 x 3/16 x 1-3/8	1.813	4.500	.625	4.328	2.266	6.688	30°	36	45°	3/16 x 3/16
180	1.000	1.56	3/16 x 3/16 x 1-3/8	1.891	4.500	.875	4.391	2.266	6.688	30°	36	45°	3/16 x 3/16
210	1.500	.312	1/4 x 1/4	2.500	8.500	1.125	5.391	2.438	9.219	25°	36	45°	1/4 x 1/4

Specifications

Model Size	Voltage DC	Static Torque lb. ft.	Max. RPM	Inertia-WR ²		Weight (lbs)	NEMA Frame Size
				Rotor	Shaft		
50	6, 24, 90	16	3600	.020	.001	6.4	56C/48Y*
100	6, 24, 90	30	3600	.046	.002	8.4	56C/48Y**
180	6, 24, 90	30	3600	.046	.002	8.4	182C/143TC 184C/145TC
210	6, 24, 90	95	3600	.188	.017	19.8	213C/182TC 215C/184TC

* For 56C/48Y Frame motors 3/4 HP and smaller the EM-100 size may be used where extended life is desirable.

** EM-100 size is recommended for motors 1 HP and larger.

For NEMA standard frame sizes, see page 137.

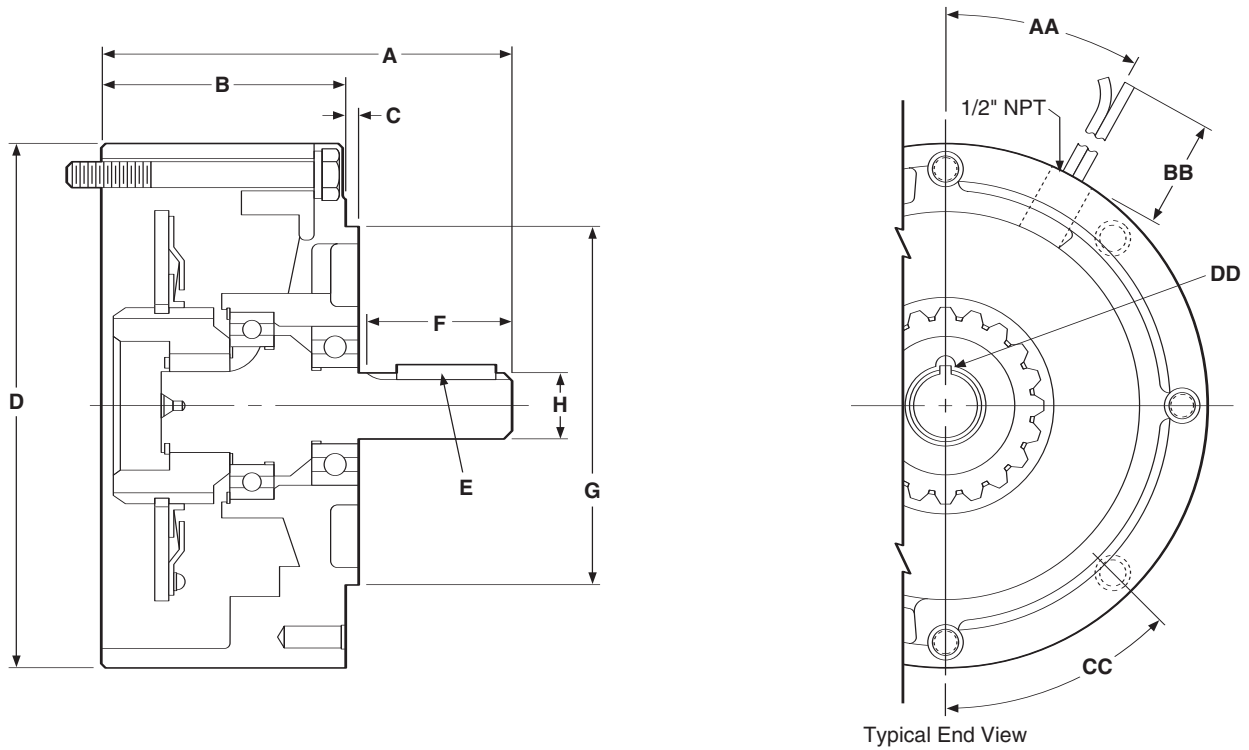

All dimensions are nominal, unless otherwise noted.

Size	A Max.	B	C Max.	D Dia.	E	F Min.	G Pilot Dia.	H Dia.	AA	BB Min.	CC	DD Key
50	5.188	3.125	.156	6.687	3/16 x 3/16 x 1-3/8	1.813	4.500	.625	30°	36	45°	3/16 x 3/16
100	5.188	3.125	.156	6.687	3/16 x 3/16 x 1-3/8	1.813	4.500	.625	30°	36	45°	3/16 x 3/16
180	5.266	3.125	.313	6.687	3/16 x 3/16 x 1-3/8	1.891	4.500	.875	30°	36	45°	3/16 x 3/16
210	7.578	4.609	.313	9.344	1/4 x 1/4 x 2	2.500	8.500	1.125	25°	36	45°	1/4 x 1/4

Specifications

Model Size	Voltage DC	Static Torque lb. ft.	Max. RPM	Armatures	Inertia-WR ²		Shaft	Weight (lbs)	NEMA Frame Size
					Arm. Hub				
50	6, 24, 90	16	3600	.007	.002	.001	4.9	56C/48Y*	
100	6, 24, 90	30	3600	.018	.003	.002	5.2	56C/48Y**	
180	6, 24, 90	30	3600	.018	.003	.002	5.2	182C/143TC 184C/145TC	
210	6, 24, 90	95	3600	.181	.021	.017	15.2	213C/182TC 215C/184TC	

* For 56C/48Y Frame motors 3/4 HP and smaller the EM-100 size may be used where extended life is desirable.

** EM-100 size is recommended for motors 1 HP and larger.

For NEMA standard frame sizes, see page 137.

EM-10/20 Clutch/Brake Combination

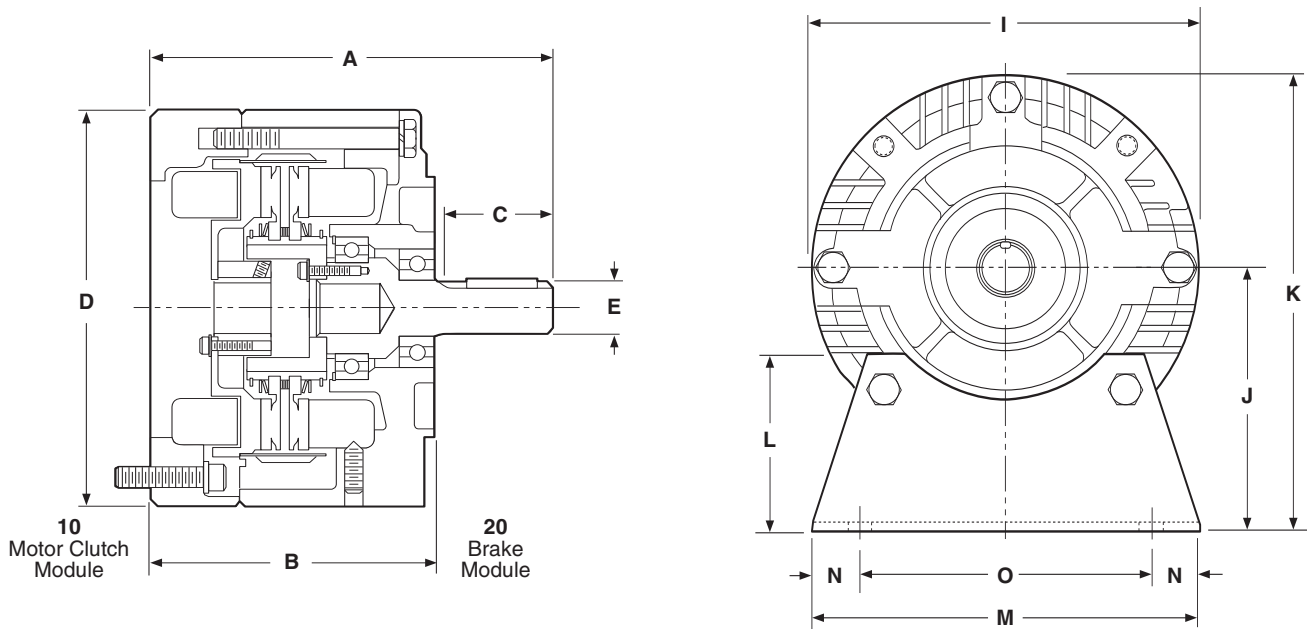

Note: Mounting base is optional and is ordered separately.
Motor Clutch (10) and Output Clutch (20) are ordered separately.

All dimensions are nominal, unless otherwise noted.

Size	A	B	C	D	E	I	J	K	L	M	N	O	NEMA Frame Size
50	6.750	4.844	1.813	6.750	.625	6.688	3.500	6.844	2.000	6.000	.500	5.000	56C/48Y*
100	6.750	4.844	1.813	6.750	.625	6.688	3.500	6.844	2.000	6.000	.500	5.000	56C/48Y**
180	6.828	4.844	1.891	6.750	.875	6.688	4.500	7.844	3.000	6.625	.813	5.000	182C/143TC 184C/145TC
210	8.891	5.922	2.500	9.250	1.125	9.688	5.250	9.906	3.375	9.000	.625	7.750	213C/182TC 215C/184TC

* For 56C/48Y Frame motors 3/4 HP and smaller the EM-100 size may be used where extended life is desirable.

For NEMA standard frame sizes, see page 137.

** EM-100 size is recommended for motors 1 HP and larger.

Motor Mount (M)

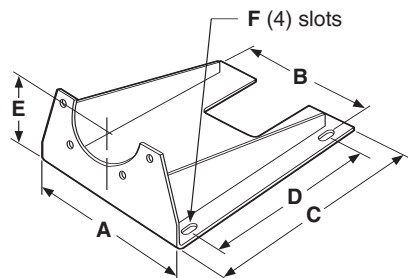

For use with 1020, 1040, 20, 20 FBB and 1020 FBC Combinations.

Size	A	B	C	D	E	F	Part No.
50/100	9.25	8.25	11.00	8.000	3.50	.797 x .406	5370-101-010
180	9.25	8.25	11.00	8.000	4.50	.797 x .406	5370-101-012/5370-101-047
210/215	11.50	10.50	12.00	9.000	5.25	.750 x .406	5371-101-012/5371-101-025

EM-10/40 Motor Clutch/Output Clutch Combination

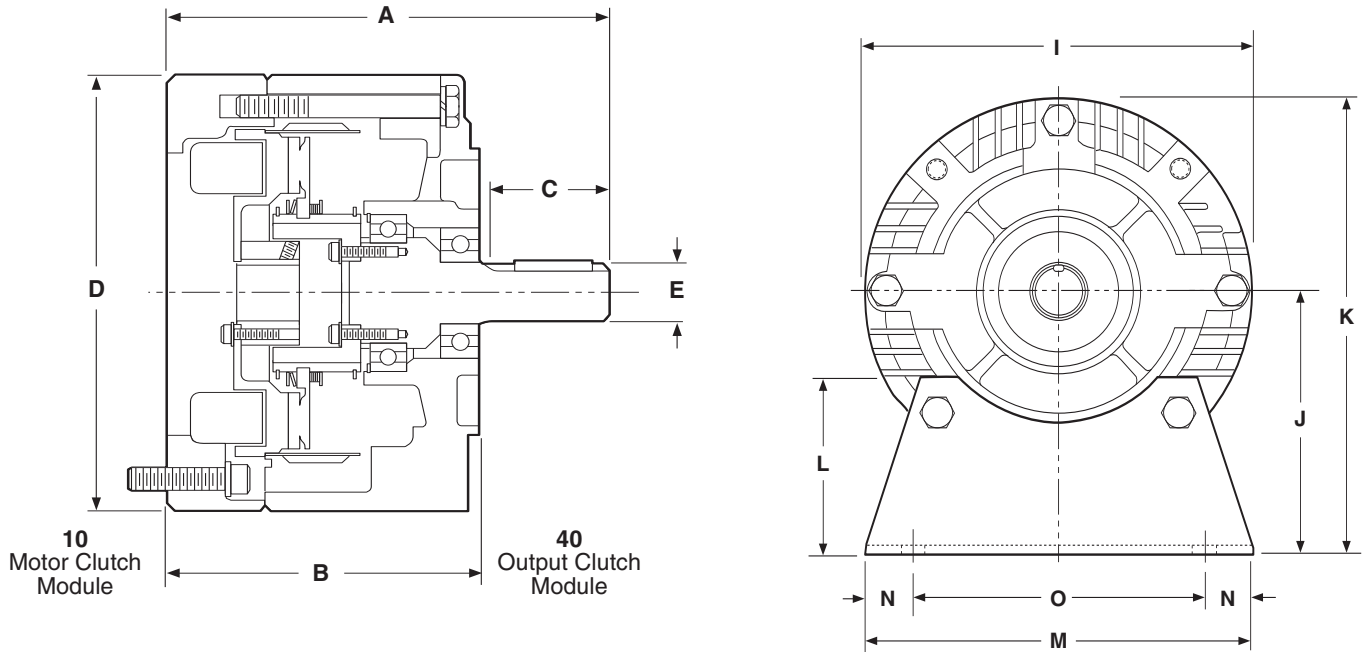

Note: Mounting base is optional and is ordered separately. Motor Clutch (10) and Output Clutch (40) are ordered separately.

All dimensions are nominal, unless otherwise noted.

Size	A	B	C	D	E	I	J	K	L	M	N	O	NEMA Frame Size
50	6.750	4.844	1.813	6.750	.625	6.688	3.500	6.844	2.000	6.000	.500	5.000	56C/48Y*
100	6.750	4.844	1.813	6.750	.625	6.688	3.500	6.844	2.000	6.000	.500	5.000	56C/48Y**
180	6.828	4.844	1.891	6.750	.875	6.688	4.500	7.844	3.000	6.625	.813	5.000	182C/143TC 184C/145TC
210	8.891	5.922	2.500	9.250	1.125	9.688	5.250	9.906	3.375	9.000	.625	7.750	213C/182TC 215C/184TC

* For 56C/48Y Frame motors 3/4 HP and smaller the EM-100 size may be used where extended life is desirable.

For NEMA standard frame sizes, see page 137.

** EM-100 size is recommended for motors 1 HP and larger.

Motor Mount (M)

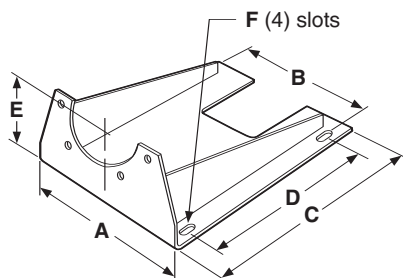

For use with 1020, 1040, 20, 20 FBB and 1020 FBC Combinations.

Size	A	B	C	D	E	F	Part No.
50/100	9.25	8.25	11.00	8.000	3.50	.797 x .406	5370-101-010
180	9.25	8.25	11.00	8.000	4.50	.797 x .406	5370-101-012/5370-101-047
210/215	11.50	10.50	12.00	9.000	5.25	.750 x .406	5371-101-012/5371-101-025

EM-20/30 Brake/Input Clutch Combination

EM-20/30-B Brake/Input Clutch Combination – Base Mounted

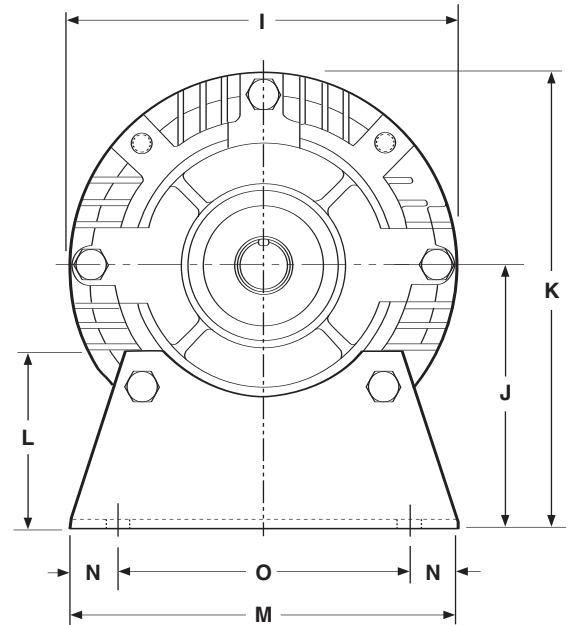
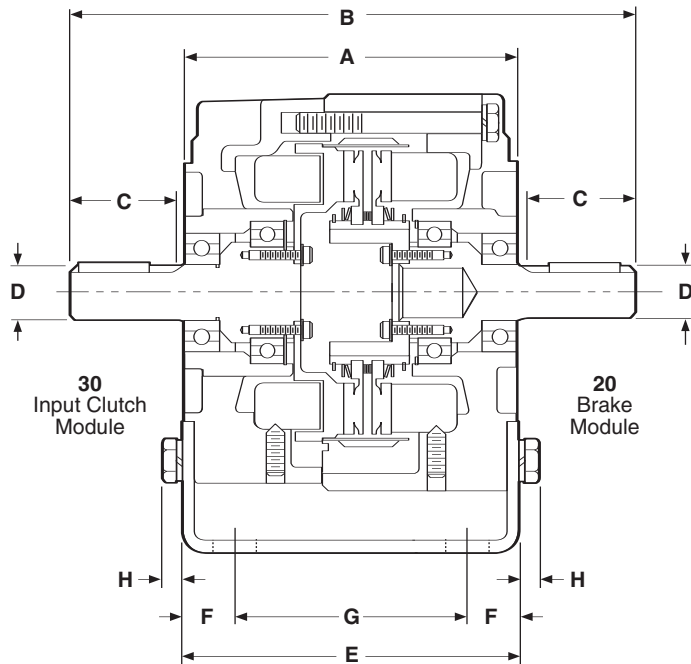

Note: Mounting base is optional and is ordered separately. Input Clutch (30) module and Brake Module (20) are ordered separately.

All dimensions are nominal, unless otherwise noted.

Size	A	B	C Min.	D	E	F	G	H	I	J	K	L	M	N	O
50	5.719	9.516	1.813	.625	5.672	.844	4.000	.344	6.688	3.500	6.844	2.000	6.000	.500	5.000
100	5.719	9.516	1.813	.625	5.672	.844	4.000	.344	6.688	3.500	6.844	2.000	6.000	.500	5.000
180	5.719	9.656	1.891	.875	5.672	.844	4.000	.344	6.688	4.500	7.844	3.000	6.625	.813	5.000
210	7.719	12.969	2.500	1.125	8.203	1.094	6.000	.438	9.688	5.250	9.906	3.375	9.000	.625	7.750

Base (B)

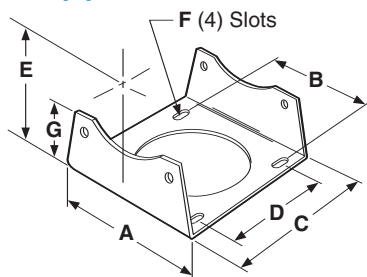

For use with 2030 and 3040 units.

Size	A	B	C	D	F	E	G	Part No.
50/100	6.000	5.000	5.672	4.000	.750 X .406	3.500	2.000	5370-101-004
180	6.625	5.000	5.672	4.000	.750 X .406	4.500	3.000	5370-101-002/5370-101-049
210/215	9.000	7.750	8.203	6.000	.750 X .531	5.250	3.385	5371-101-001/5371-101-026

**EM-30/40 Input Clutch/Output Clutch Combination
EM-30/40 Input Clutch/Output Clutch Combination – Base Mounted**

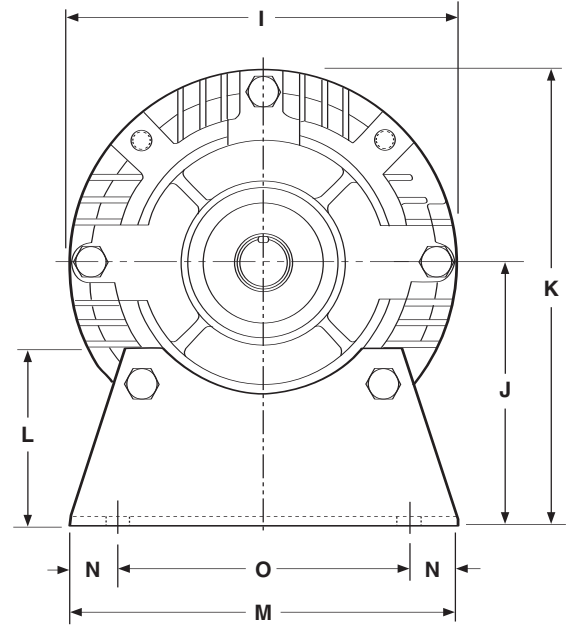
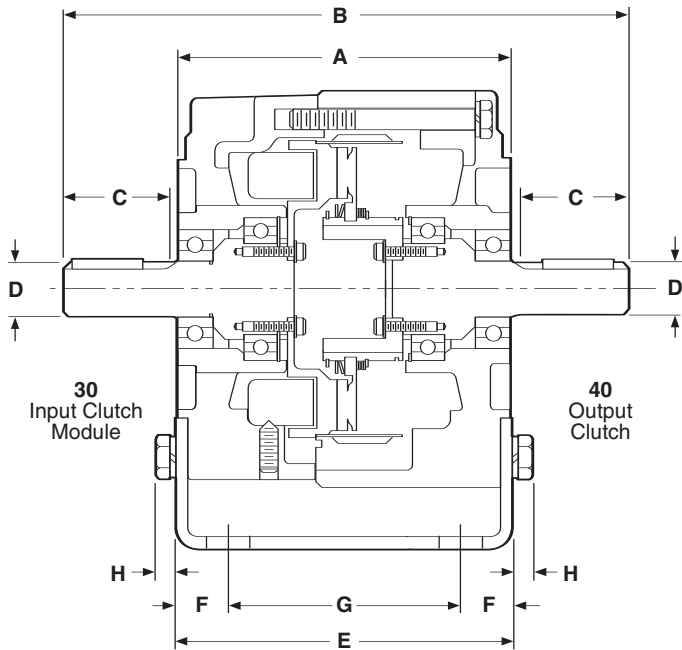

Note: Mounting base is optional and is ordered separately. Input Clutch (30) module and Output Clutch (40) are ordered separately.

All dimensions are nominal, unless otherwise noted.

Size	A	B	C Min.	D	E	F	G	H	I	J	K	L	M	N	O
50	5.719	9.516	1.813	.625	5.672	.844	4.000	.344	6.688	3.500	6.844	2.000	6.000	.500	5.000
100	5.719	9.516	1.813	.625	5.672	.844	4.000	.344	6.688	3.500	6.844	2.000	6.000	.500	5.000
180	5.719	9.656	1.891	.875	5.672	.844	4.000	.344	6.688	4.500	7.844	3.000	6.625	.813	5.000
210	7.719	12.969	2.500	1.125	8.203	1.094	6.000	.438	9.688	5.250	9.906	3.375	9.000	.625	7.750

Base (B)

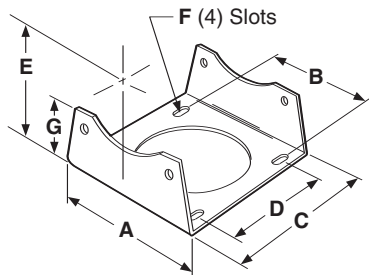

For use with 2030 and 3040 units.

Size	A	B	C	D	F	E	G	Part No.
50/100	6.000	5.000	5.672	4.000	.750 X .406	3.500	2.000	5370-101-004
180	6.625	5.000	5.672	4.000	.750 X .406	4.500	3.000	5370-101-002/5370-101-049
210/215	9.000	7.750	8.203	6.000	.750 X .531	5.250	3.385	5371-101-001/5371-101-026

Pre-assembled, C-face Clutches and Brakes

UniModules offer the ultimate in Clutch/Brake performance and convenience. UniModules offer the same performance as EM's without the assembly required.

Completely pre-assembled one-piece clutch and clutch/brake packages in five sizes. Can be motor or reducer mounted or used as a separate drive unit powered by a prime mover.

Pre-assembled, pre-aligned, and pre-burnished at the factory for rated torque directly out-of-the-box.

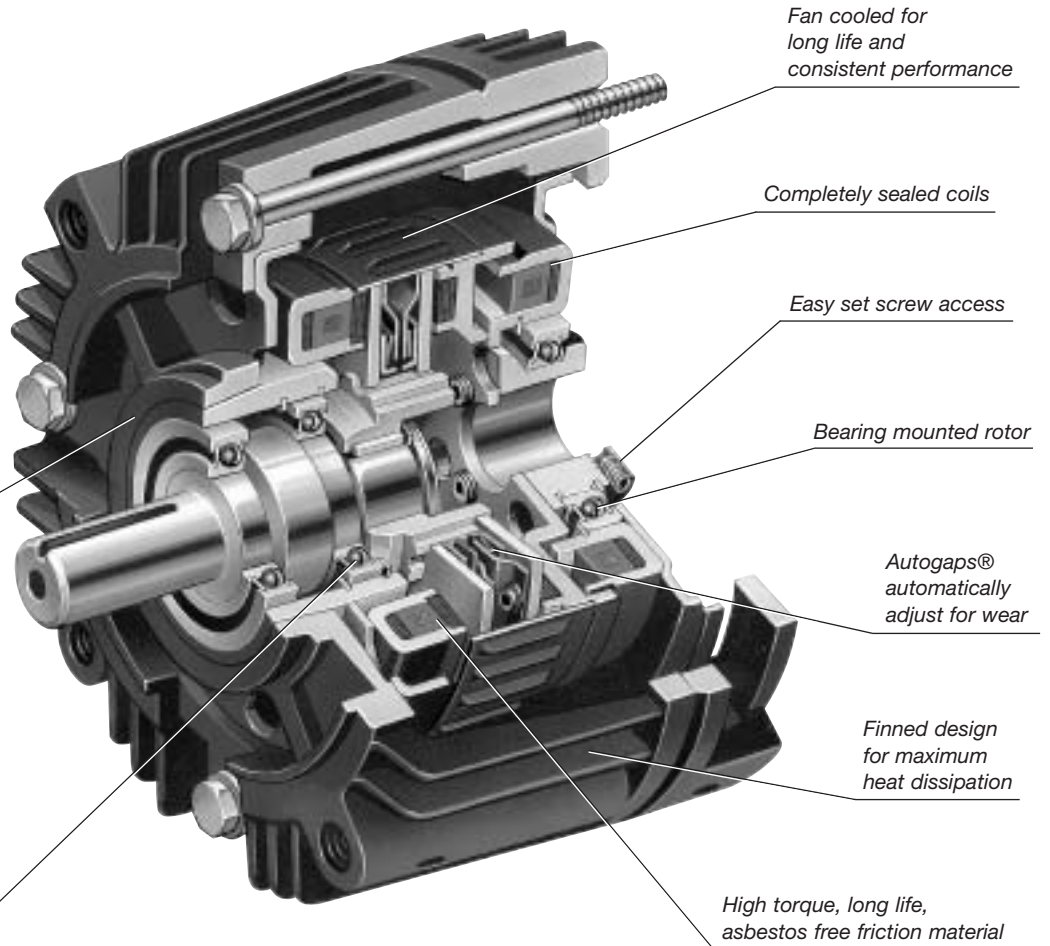

- Easy installation
- Available with standard power-on and electrically released power-off brake units
- Fan cooled for high cycle rate operation
- Maintenance Free
- Available in 50, 100, 180, 210, and 215 sizes. NEMA C-face design
- UL rated, CSA certified
- Can be applied with control fitted as standard
- Bearing mounted clutch rotor eases assembly alignment
- Single access hole for all wires

Easy Installation

1. Slide UniModule on to motor shaft.
2. Position vent holes to bottom and insert four capscrews.
3. Use Allen wrench to tighten rotor set screws.



1.



2.



3.

Clutch Combinations



1040

Motor Clutch/Output Clutch

Use for clutch only applications. Has hollow bore input for mounting directly to C-face motors. Shaft and C-face on output side of unit accommodates reducer, parallel drive or coupling. Motor Clutch is fan cooled for long life and consistent performance. Basic components are field, rotor and armature. See page 29.



3040

Input Clutch/Output Clutch

Use for clutch only applications. Features dual C-faces and shafts. Unit input from parallel drive or coupling. Output to reducer. Input Clutch is fan cooled and has sealed coils. Twin bearing mounted shaft maintains tight concentricities. The Output Clutch utilizes Autogaps™ which automatically adjust armature for wear. Basic components are field, rotor and armature. See page 31.



3040-B

Input Clutch/Output Clutch – with Accessory Base Mounting

Base mounting allows the clutch unit to be utilized as a separate drive unit. Attach with pulleys, sprockets, etc. See page 31.

Clutch/Brake Combinations



1020

Motor Clutch/Brake

Use for clutch/brake applications. Has hollow bore input for mounting directly to C-face motors. Brake shaft and C-face on output side accommodate a reducer, parallel drive or coupling. Basic components: field, rotor, 2 armatures and power-on magnet. See page 28.

1020-FBC

Motor Clutch/Electrically Released Brake

Use for clutch/power-off brake applications. Has clutch input and brake on output side. Employs powerful permanent magnets for maximum torque when power is removed from the brake coil. Basic components are field, rotor, 2 armatures and power-off magnet. See page 119 for specifications.



2030

Input Clutch/Brake

Use for clutch/brake applications. Features dual C-faces and shafts. Input from parallel drive or coupling. Output to reducer. Basic components are field, rotor, 2 armatures and power-on magnet. See page 30.

2030-FBC

Input Clutch/Electrically Released Brake

Use for clutch/power-off brake applications. Has shafts on input and output sides. When electrical power is applied to the brake coil the brake releases. Ideal for dynamic cycling operations. Basic components are field, rotor, 2 armatures and power-off magnet. See page 119 for specifications.



2030-B

Input Clutch/Brake – with Accessory Base Mounting

Base mounting allows the clutch/brake units to be utilized as a separate drive unit. Attach with pulleys, sprockets, etc. See page 30.

2030-FBC-B

Input Clutch/Electrically Released Brake with Accessory Base Mounting

See page 130 for Electrically Released Brake specifications.

Selection

UniModule clutch, brake and clutch/brake units may be mounted directly to NEMA C-face motors and reducers, or can be base mounted.

1. Select Configuration

a. NEMA C-face Mounting

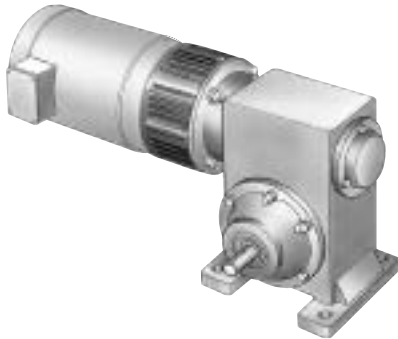

To select the correct UniModule package, determine the NEMA frame size of your motor and/or reducer, and choose the corresponding size UniModule from the Frame Size Selection chart.

Size UM-100 modules utilize a 5/8" diameter shaft to fit 56C/48Y motor frames with components of UM-180 units for higher torque and heat dissipation capacity than the UM-50.

UM-100 modules are available in 1020 and 2030 clutch/brake and 1040 and 3040 clutch configurations. For C-face mounting, select either a 1020 clutch/brake or a 1040 clutch configuration. The 2030 and 3040 configurations are for base mounting.

Frame Size Selection

NEMA Frame Size	UniModule Size
56C/48Y	UM-50* UM-100**
182C/143TC 184C/145TC	UM-180
213C/182TC 215C/184TC	UM-210
213TC/215TC	UM-215

* For 56C/48Y Frame motors 3/4 HP and smaller the UM-100 size may be used where extended life is desirable.

** UM-100 size is recommended for motors 1 HP and larger.

b. Base Mounting

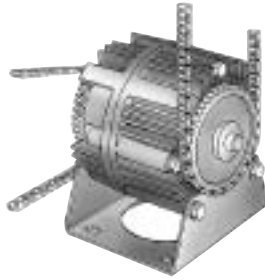

UniModule assemblies may be mounted as separate drive units driven from the prime mover by V-belts, chain and sprockets, couplings, timing belts and other standard power transmission components.

Select the correct size module from the Horsepower vs. Shaft Speed chart by determining the motor horsepower and RPM at the module location. The correct size UniModule is shown at the intersection of the HP and operating speed.

For additional sizing information, refer to the technical sizing procedure (step 2).

2. Determine Technical Requirements

Technical considerations for sizing and selection are torque and heat dissipation. Each merits careful consideration, especially heat dissipation as over time, use in excessive temperature environments will have an adverse effect on bearing life and coil wire insulation integrity.

Compare the calculated torque requirement with the average dynamic torque ratings. Select a unit with adequate torque. If the unit selected on torque is different than the unit selected based on heat, select the larger size unit.

Horsepower vs. Shaft Speed

HP	SHAFT SPEED AT CLUTCH (IN RPM)																		
	100	200	300	400	500	600	700	800	900	1000	1100	1200	1500	1800	2000	2400	3000	3600	
1/4	UM-50																		
1/2	UM-50																		
3/4	UM-100 or UM-180																		
1	UM-100 or UM-180																		
1-1/2	UM-100 or UM-180																		
2	UM-210 OR UM-215																		
3	UM-210 OR UM-215																		
5	UM-215																		
7-1/2	UM-215																		

a. Heat Dissipation Sizing

Friction surfaces slip during the initial period of engagement and, as a result, heat is generated. The clutch/brake selected must have a heat dissipation rating greater than the heat generated by the application. Therefore, in high inertia or high cycle rate applications, it is necessary to check the heat dissipation carefully. Inertia, speed and cycle rate are the required parameters.

Heat dissipation requirement is calculated as follows:

$$E = 1.7 \times WR^2 \times (N/100)^2 \times F$$

where:

$$E = \text{Heat (lb. ft./min.)}$$

WR^2 = Total reflected inertia at the clutch/brake shaft. Include the clutch/brake output inertia. (lb.ft.²)

N = Speed in revolutions per minute. (RPM)

F = Cycle rate in cycles per minute (CPM)

Compare the calculated heat generated in the application to the unit ratings using the heat dissipation curves. Select the appropriate unit that has adequate heat dissipation ability.

Heat Dissipation Curves

Size 50

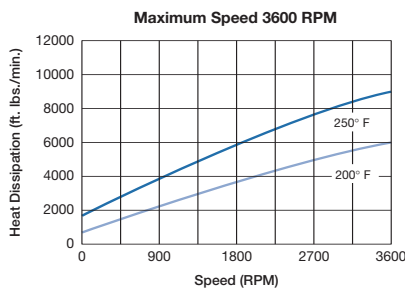

Size 100/180

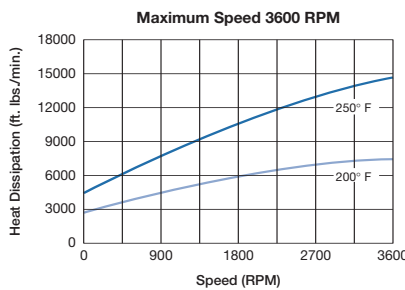

Size 210/215

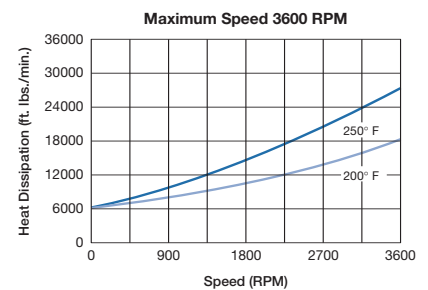

b. Torque Sizing

For most applications, the correct size clutch/brake can be selected from the Horsepower vs. Shaft Speed chart located at the bottom of this page. Determine the motor horsepower and the RPM at the clutch/brake. The correct size unit is shown at the intersection of horsepower and shaft speed.

If the static torque requirements are known, refer to the technical ratings chart to select a unit.

For some applications, the torque requirement is determined by the time allowed to accelerate and decelerate the load. (This time is generally specified in milliseconds.) For these applications, it is necessary to determine the torque requirement based on load inertia and the time allowed for engagement.

The torque requirements are calculated as follows:

$$T = (WR^2 \times N) / (308 \times t)$$

where:

$$T = \text{Average Dynamic Torque (lb. ft.)}$$

WR^2 = Total reflected inertia at the clutch/brake shaft. Include the clutch/brake output inertia. (lb. ft.²)

N = Speed in revolutions per minute. (RPM)

t = Time allowed for the engagement (sec)

C-face Clutch/Power-on Brake Dynamic Torque Curves

Size 50

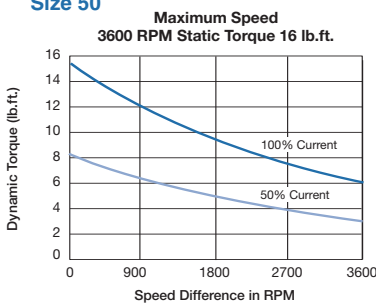

Size 100/180

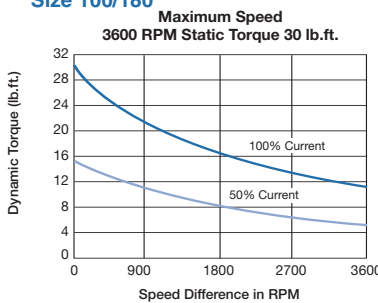

Size 210/215

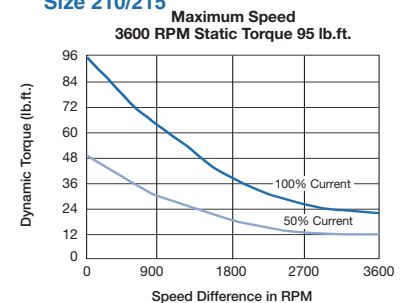

Specifications

UM Size	Static Torque lb. ft.	Maximum RPM	Voltage DC
50	16	3600	6, 24, or 90
100	30	3600	6, 24, or 90
180	30	3600	6, 24, or 90
210	95	3600	6, 24, or 90
215	95	3600	6, 24, or 90

3. Accessories

Warner Electric UniModules can be fitted with several accessories to extend their capacity and ease of mounting.

a. Conduit Box

NEMA 4 and UL listed, available in standard and washdown versions.



b. Mounting Brackets

Two styles of mounting brackets are available for simplified installation. The base mount is used with the 2030 and 3040 configurations. A motor mount is also available and provides sturdy support for 1020 and 1040 units and a motor.





4. Select Control

Warner Electric manufactures clutch/brake controls to meet several system functions including:

- On/Off
- Torque adjust
- Over excitation
- Position loop

Many requirements beyond function can impact control selection. See the Controls Section on page 141 for complete information.

Part Numbers

Configuration	Model No.	Voltage D.C.	Part No.
	1020	UM-50-1020	6 5370-273-016
	UM-50-1020	24 5370-273-018	
	UM-50-1020	90 5370-273-017	
	UM-100-1020	6 5370-273-026	
	UM-100-1020	24 5370-273-028	
	UM-100-1020	90 5370-273-027	
	UM-180-1020	6 5370-273-006	
	UM-180-1020	24 5370-273-008	
	UM-180-1020	90 5370-273-007	
	UM-210-1020	6 5371-273-002	
	UM-210-1020	24 5371-273-004	
	UM-210-1020	90 5371-273-003	
	UM-215-1020	6 5371-273-076	
	UM-215-1020	24 5371-273-077	
	UM-215-1020	90 5371-273-078	
Motor Clutch/Brake	UM-215-1020	90 5371-273-078	
	UM50-1020	w/CBC-150-1 90 5370-9	
	UM100-1020	w/CBC-150-1 90 5370-10	
	UM180-1020	w/CBC-150-1 90 5370-273-122	
	UM210-1020	w/CBC-150-1 90 5371-4	
UM215-1020	w/CBC-150-1 90 5371-273-090		
	1040	UM-50-1040	6 5370-271-004
	UM-50-1040	24 5370-271-006	
	UM-50-1040	90 5370-271-005	
	UM-100-1040	6 5370-271-024	
	UM-100-1040	24 5370-271-026	
	UM-100-1040	90 5370-271-025	
	UM-180-1040	6 5370-271-014	
	UM-180-1040	24 5370-271-016	
	UM-180-1040	90 5370-271-015	
	UM-210-1040	6 5371-271-002	
	UM-210-1040	24 5371-271-004	
	UM-210-1040	90 5371-271-003	
	UM-215-1040	6 5371-271-026	
	UM-215-1040	24 5371-271-027	
	UM-215-1040	90 5371-271-028	
Motor Clutch Output Clutch	UM-215-1040	90 5371-271-028	
	2030	UM-50-2030	6 5370-273-021
	UM-50-2030	24 5370-273-023	
	UM-50-2030	90 5370-273-022	
	UM-100-2030	6 5370-273-031	
UM-100-2030	24 5370-273-033		
UM-100-2030	90 5370-273-032		
UM-180-2030	6 5370-273-011		
UM-180-2030	24 5370-273-013		
UM-180-2030	90 5370-273-012		
UM-210-2030	6 5371-273-007		
UM-210-2030	24 5371-273-009		
UM-210-2030	90 5371-273-008		
UM-215-2030	6 5371-273-043		
UM-215-2030	24 5371-273-044		
UM-215-2030	90 5371-273-045		
Input Clutch/Brake	UM-215-2030	90 5371-273-045	
	3040	UM-50-3040	6 5370-271-009
	UM-50-3040	24 5370-271-011	
	UM-50-3040	90 5370-271-010	
	UM-100-3040	6 5370-271-029	
UM-100-3040	24 5370-271-031		
UM-100-3040	90 5370-271-030		
UM-180-3040	6 5370-271-019		
UM-180-3040	24 5370-271-021		
UM-180-3040	90 5370-271-020		
UM-210-3040	6 5371-271-007		
UM-210-3040	24 5371-271-009		
UM-210-3040	90 5371-271-008		
UM-215-3040	6 5371-271-021		
UM-215-3040	24 5371-271-022		
UM-215-3040	90 5371-271-023		

Accessories

Description	UM Size	Part No.
Conduit Box	All sizes	5370-101-042
Base Mount Kit for 2030, 3040	50/100	5370-101-004
	180	5370-101-002
	210/215	5371-101-001
Motor Mount Kit for 1020, 1040	50/100	5370-101-010
	180	5370-101-012
	210/215	5371-101-012

How to Order

Motor or Reducer Mounted

Simply combine the size number with the configuration of the required UniModule.

Specify voltage. See chart for specific part numbers. Power-off brake UniModules are found on page 120. Order optional conduit box if desired.

Example

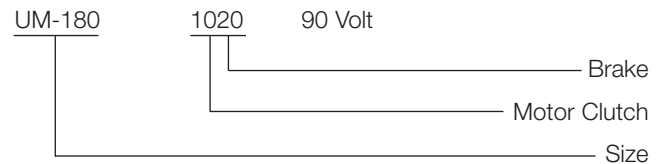

Base Mounted

Simply combine the size number with the configuration of the required UniModule. Specify voltage. See chart for specific part numbers. Power-off brake UniModules are found on page 120. Order optional conduit box if desired.

Example

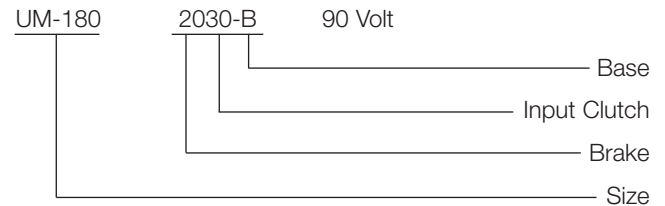

Select Appropriate Power Supply/Control. See the Controls Section beginning on page 141.

UM-1020 Motor Clutch/Brake Combination

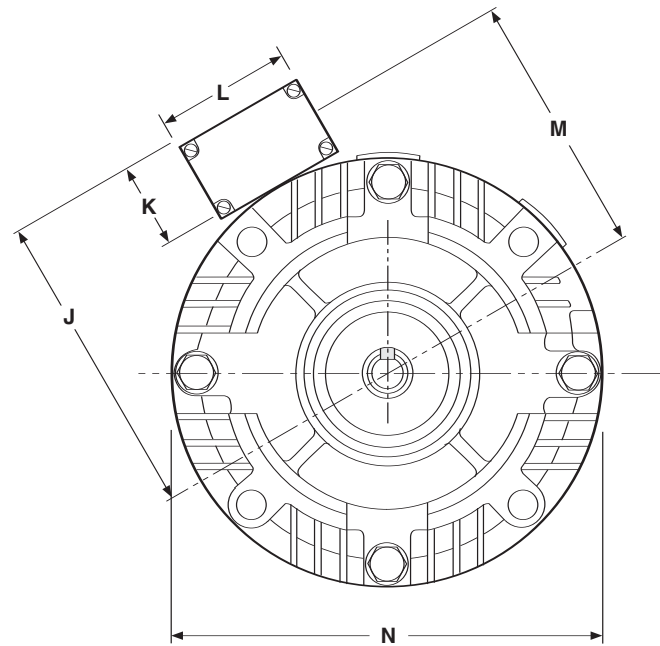
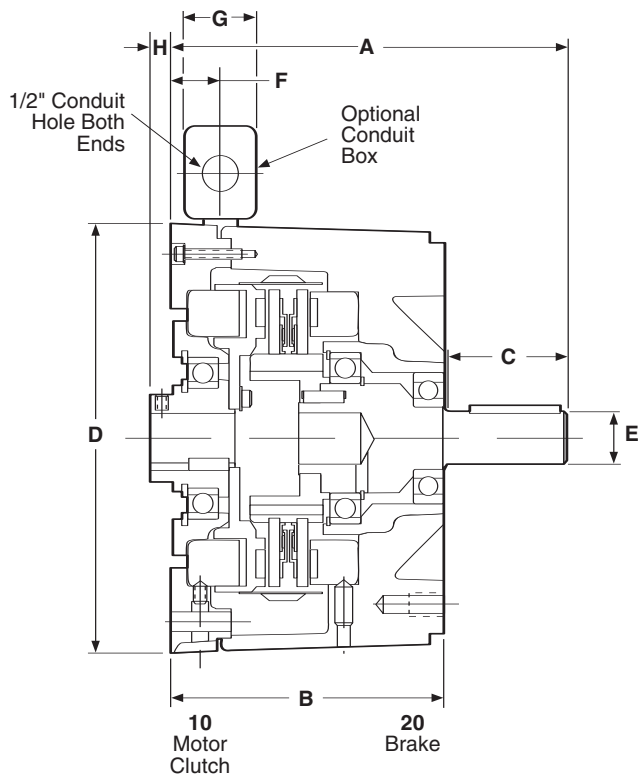

Note: Some 90 VDC units are available with pre-installed controls. On all other modules, conduit box is optional and is ordered separately.

All dimensions are nominal, unless otherwise noted.

Size	A	B	C	D	E	F	G	H
50	6.750	4.844	1.813	6.750	.625	.937	2.203	—
100	6.750	4.844	1.812	6.750	.625	.937	2.203	.104
180	6.828	4.844	1.812	6.750	.875	.937	2.203	—
210	8.891	5.922	2.500	9.250	1.125	.500	2.203	.500
215	9.391	5.922	3.000	9.250	1.375	.500	2.203	.500

Size	I	J	K	L	M	N
50	3.250	5.531	2.188	3.250	4.438	6.688
100	3.250	5.531	2.188	3.250	4.438	6.688
180	3.250	5.531	2.188	3.250	4.438	6.688
210	3.250	6.859	2.188	3.250	5.766	9.688
215	3.250	6.859	2.188	3.250	5.766	9.688

Specifications

Model Size	Voltage DC	Static Torque lb. ft.	Max. RPM	NEMA Frame Size
50	6, 24, 90	16	3600	56C/48Y*
100	6, 24, 90	30	3600	56C/48Y**
180	6, 24, 90	30	3600	182C/143TC 184C/145TC
210	6, 24, 90	95	3600	213C/182TC 215C/184TC
215	6, 24, 90	95	3600	213TC/215TC

* For 56C/48Y Frame motors 3/4 HP and smaller the UM-100 size may be used where extended life is desirable.

** UM-100 size is recommended for motors 1 HP and larger.

For NEMA standard frame sizes, see page 137.

UM-1040 Motor Clutch/Output Clutch Combination

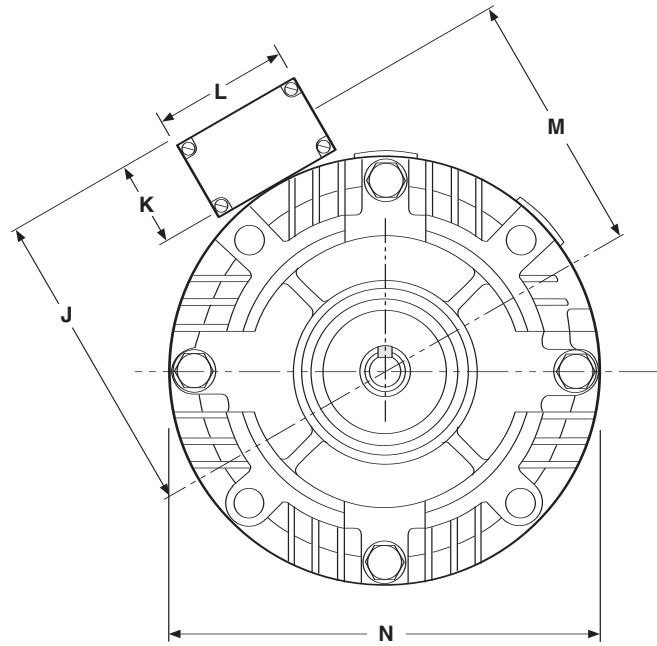
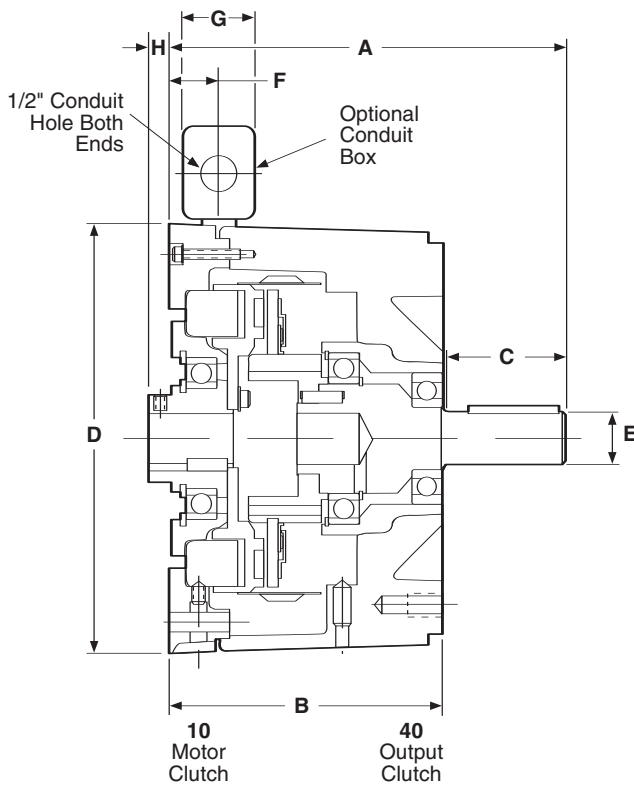

Note: Conduit box is optional and is ordered separately.

All dimensions are nominal, unless otherwise noted.

Size	A	B	C	D	E	F	G	H
50	6.750	4.844	1.813	6.750	.625	.937	2.203	—
100	6.750	4.844	1.812	6.750	.625	.937	2.203	.104
180	6.828	4.844	1.812	6.750	.875	.937	2.203	—
210	8.891	5.922	2.500	9.250	1.125	.500	2.203	.500
215	9.391	5.922	3.000	9.250	1.375	.500	2.203	.500

Size	I	J	K	L	M	N
50	3.250	5.531	2.188	3.250	4.438	6.688
100	3.250	5.531	2.188	3.250	4.438	6.688
180	3.250	5.531	2.188	3.250	4.438	6.688
210	3.250	6.859	2.188	3.250	5.766	9.688
215	3.250	6.859	2.188	3.250	5.766	9.688

Specifications

Model Size	Voltage DC	Static Torque lb. ft.	Max. RPM	NEMA Frame Size
50	6, 24, 90	16	3600	56C/48Y*
100	6, 24, 90	30	3600	56C/48Y**
180	6, 24, 90	30	3600	182C/143TC 184C/145TC
210	6, 24, 90	95	3600	213C/182TC 215C/184TC
215	6, 24, 90	95	3600	213TC/215TC

* For 56C/48Y Frame motors 3/4 HP and smaller the UM-100 size may be used where extended life is desirable.

** UM-100 size is recommended for motors 1 HP and larger.

For NEMA standard frame sizes, see page 137.

UM-2030 Input Clutch/Brake Combination
UM-2030-B Input Clutch/Brake Combination – Base Mounted

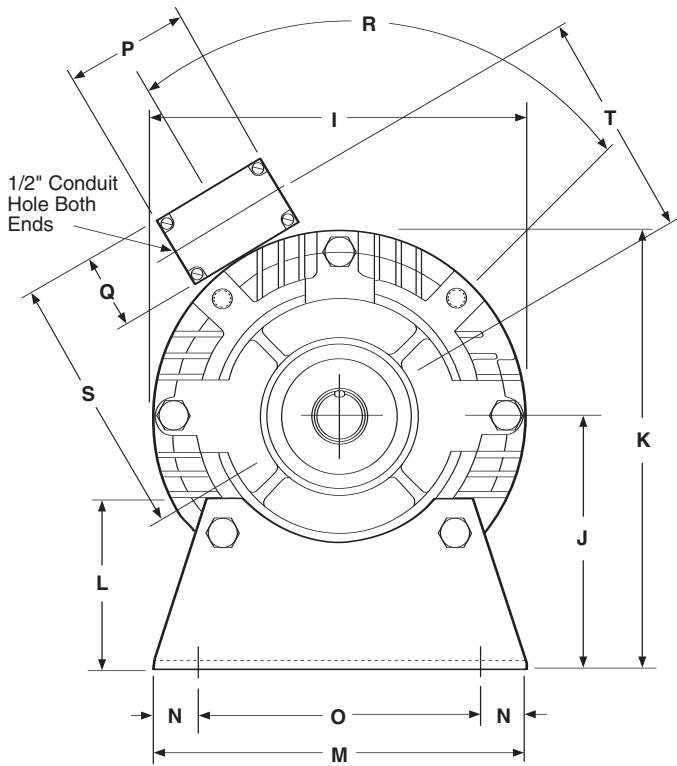
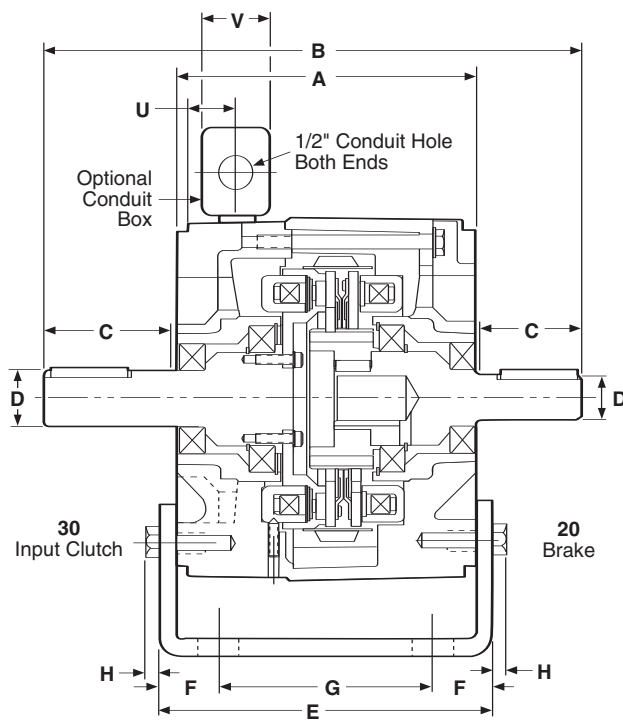

Note: Mounting base and conduit box are optional and are ordered separately.

All dimensions are nominal unless otherwise noted.

Size	A	B	C Min.	D	E	F	G	H	I	J	K	L	M
50	5.719	9.516	1.813	.625	5.672	.844	4.000	.344	6.688	3.500	6.844	2.000	6.000
100	5.719	9.516	1.890	.625	5.672	.844	4.000	.344	6.688	3.500	6.844	2.000	6.000
180	5.719	9.656	1.890	.875	5.672	.844	4.000	.344	6.688	4.500	7.844	3.000	6.625
210	7.719	12.969	2.500	1.125	8.203	1.094	6.000	.437	9.688	5.250	9.906	3.375	9.000
215	7.719	12.969	2.500	1.375	8.203	1.094	6.000	.437	9.688	5.250	9.906	3.375	9.000

Size	N	O	P	Q	R	S	T	U	V
50	.500	5.000	3.125	2.188	75°	5.531	4.438	1.125	2.203
100	.500	5.000	3.125	2.188	75°	5.531	4.438	1.125	2.203
180	.500	5.000	3.125	2.188	75°	5.531	4.438	1.125	2.203
210	.625	7.750	3.125	2.188	70°	6.859	5.766	1.625	2.203
215	.625	7.750	3.125	2.188	70°	6.859	5.766	1.625	2.203

Specifications

Model Size	Voltage DC	Static Torque lb. ft.	Max. RPM
50	6, 24, 90	16	3600
100	6, 24, 90	30	3600
180	6, 24, 90	30	3600
210	6, 24, 90	95	3600
215	6, 24, 90	95	3600

**UM-3040 Input Clutch/Output Clutch Combination
UM-3040-B Input Clutch/Output Clutch Combination—Base Mounted**

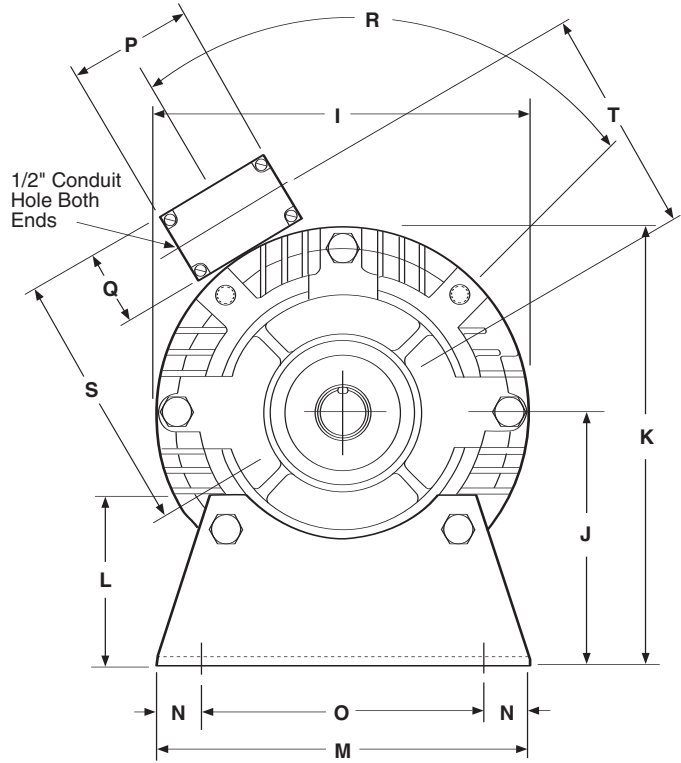
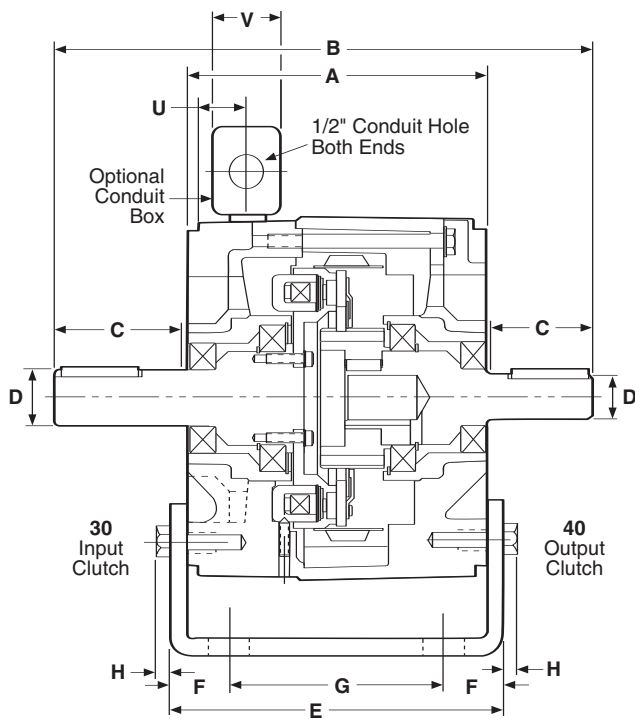

Note: Mounting base and conduit box are optional and are ordered separately.

All dimensions are nominal unless otherwise noted.

Size	A	B	C Min.	D	E	F	G	H	I	J	K	L	M
50	5.719	9.516	1.813	.625	5.672	.844	4.000	.344	6.688	3.500	6.844	2.000	6.000
100	5.719	9.516	1.890	.625	5.672	.844	4.000	.344	6.688	3.500	6.844	2.000	6.000
180	5.719	9.656	1.890	.875	5.672	.844	4.000	.344	6.688	4.500	7.844	3.000	6.625
210	7.719	12.969	2.500	1.125	8.203	1.094	6.000	.437	9.688	5.250	9.906	3.375	9.000
215	7.719	12.969	2.500	1.375	8.203	1.094	6.000	.437	9.688	5.250	9.906	3.375	9.000

Size	N	O	P	Q	R	S	T	U	V
50	.500	5.000	3.125	2.188	75°	5.531	4.438	1.125	2.203
100	.500	5.000	3.125	2.188	75°	5.531	4.438	1.125	2.203
180	.500	5.000	3.125	2.188	75°	5.531	4.438	1.125	2.203
210	.625	7.750	3.125	2.188	70°	6.859	5.766	1.625	2.203
215	.625	7.750	3.125	2.188	70°	6.859	5.766	1.625	2.203

Specifications

Model Size	Voltage DC	Static Torque lb. ft.	Max. RPM
50	6, 24, 90	16	3600
100	6, 24, 90	30	3600
180	6, 24, 90	30	3600
210	6, 24, 90	95	3600
215	6, 24, 90	95	3600

High Performance with Extended Life

UniModules with ceramic friction material are pre-burnished during manufacturing to provide rated torque performance upon start up. They have been designed to mate easily with industry standard motors, reducers and other power transmission components.

- Bolt-it-down, wire-it-up . . . it's ready to go.
- Available in 3 sizes; 50, 180 and 210 and 2 configurations; 1020 and 2030.
- Standard voltages available 24V and 90V DC.
- C-face or foot mounted.
- No maintenance required.
- Accurate positioning when used with CBC-1000 Indexer and CBC-700 OEX control.

Heavy duty bearings maintain tight concentricity and running efficiency

NEMA C-face compatible design for easy mounting

Finned design for maximum heat dissipation

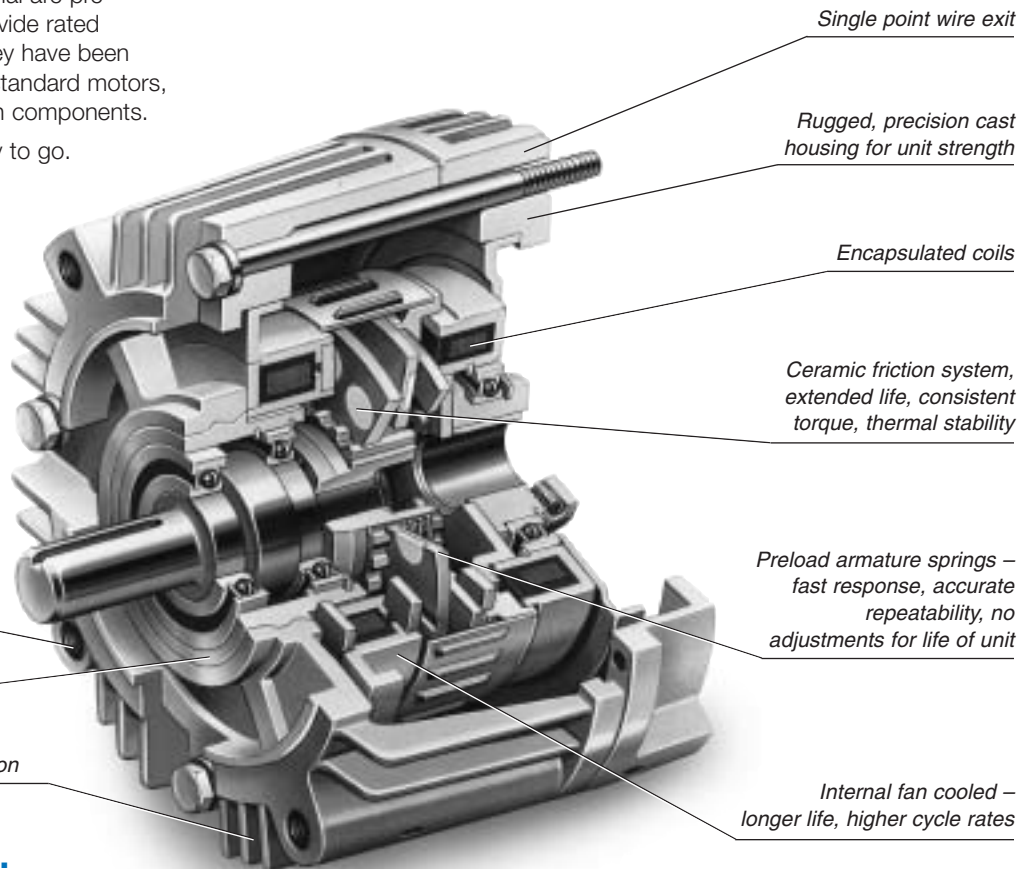

The Ceramic Difference . . .

Extended Life for High Cycle Rate Use

Ceramic faced clutches and brakes have been designed specifically for rapid cycling applications to satisfy today's needs for high speed equipment. Ceramic friction material provides excellent wear resistance that extends life 3 to 5 times that of standard clutch/brakes in demanding applications.



Consistent Torque and Cycle Repeatability

Preloaded armatures keep the ceramic friction surfaces lightly in contact to provide consistent torque and cycle-to-cycle repeatability. Variation is reduced by up to 30% over standard units. Autogaps are not required.

Controllability – Smooth Start/Stop

With the ceramic friction surfaces always in contact, dynamic torque response is fast and precise. When used with a CBC-700 over-excitation control and CBC-1000 programmable counter, exceptional closed loop clutch/brake performance can be achieved approaching that of more expensive motion control technologies – The PerformancePlus difference!

UM-C Product Life

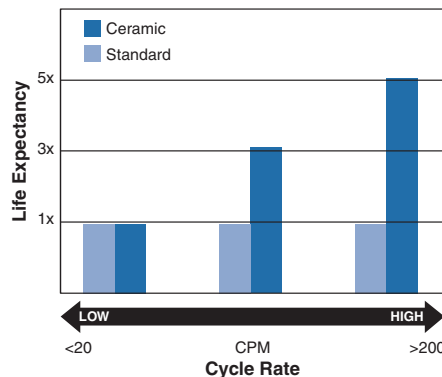

UM-C Cycle Repeat

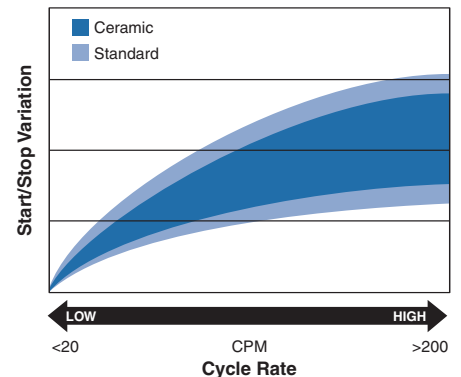

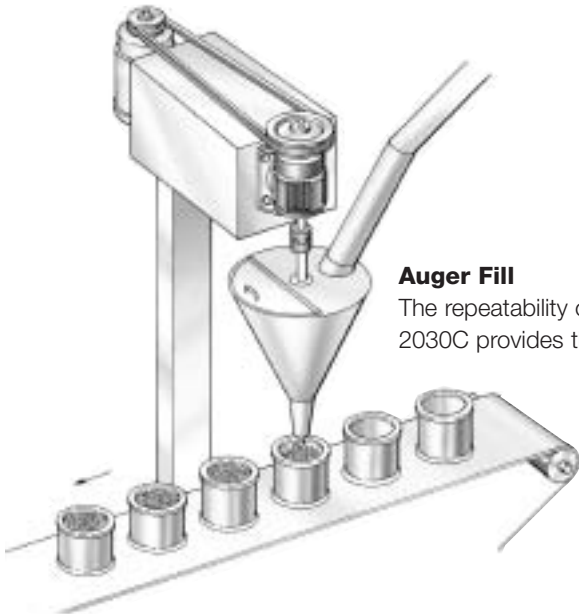

Auger Fill
The repeatability of the Ceramic UniModule 2030C provides the consistent fill levels.

UniModule 2030-C with base assembly mounted as a separate drive unit.

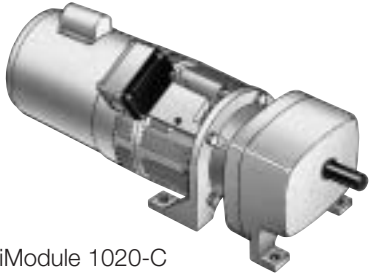
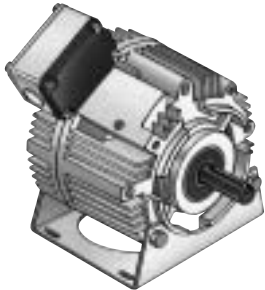

UniModule 1020-C
clutch/brake between
C-face motor and reducer.

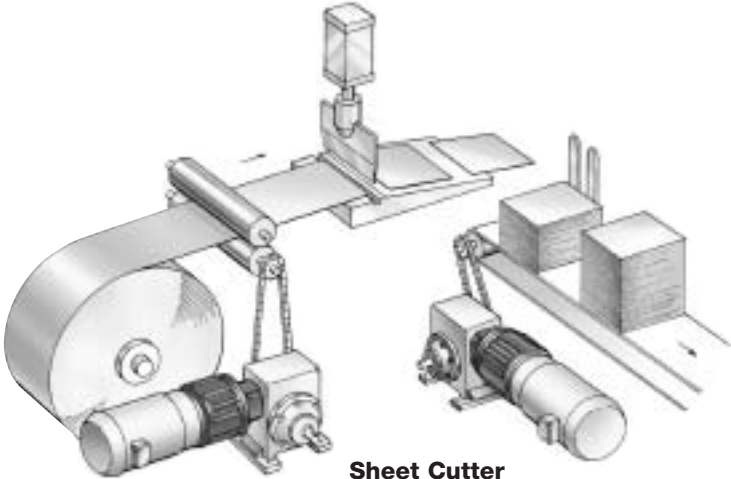

Sheet Cutter
The Ceramic UniModules provide
high cycle rate clutch/brake indexing.

Selection

Ceramic UniModule clutch/brake units may be mounted directly to NEMA C-face motors and reducers, or can be base mounted.

1. Determine Mounting Configuration

a. NEMA C-face Mounting (1020 Configuration)

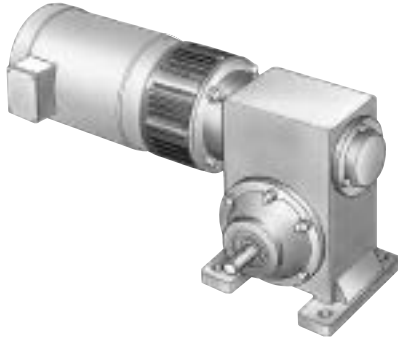

To select the correct Ceramic UniModule package, determine the NEMA frame size of your motor and/or reducer, and choose the corresponding size UniModule from the Frame Size Selection chart.

b. Base Mount (2030 Configuration)



Ceramic UniModule assemblies may be mounted as separate drive units driven from the prime mover by V-belts, chain and sprockets, couplings, timing belts and other standard power transmission components.

Select the correct size module from the Horsepower vs. Shaft Speed chart by determining the motor horsepower and RPM at the module location. The correct size UniModule is shown at the intersection of the HP and operating speed. For additional sizing information, refer to the technical sizing procedure (step 2).

2. Determine Technical Requirements

Technical considerations for sizing and selection are torque and heat dissipation. Each merits careful consideration, especially heat dissipation as over time, use in excessive temperature environments will have an adverse effect on bearing life and coil wire insulation integrity.

Compare the calculated torque requirement with the average dynamic torque ratings. Select a unit with adequate torque. If the unit selected on torque is different than the unit selected based on heat, select the larger size unit.

Frame Size Selection

NEMA Frame Size	UniModule Size
56C/48Y	UM-50-C
182C/143TC 184C/145TC	UM-180-C
213C/182TC 215C/184TC	UM-210-C

Horsepower vs. Shaft Speed

HP	SHAFT SPEED AT CLUTCH (IN RPM)																			
	100	200	300	400	500	600	700	800	900	1000	1100	1200	1500	1800	2000	2400	3000	3600		
1/4	UM-50-C																			
1/2	UM-180-C																			
3/4	UM-180-C																			
1	UM-210-C																			
1-1/2	UM-210-C																			
2	UM-210-C																			
3	UM-210-C																			
5	UM-210-C																			
7-1/2	UM-210-C																			
10	UM-210-C																			

a. Heat Dissipation Sizing

Friction surfaces slip during the initial period of engagement and, as a result, heat is generated. The clutch/brake selected must have a heat dissipation rating greater than the heat generated by the application. Therefore, in high inertia or high cycle rate applications, it is necessary to check the heat dissipation carefully. Inertia, speed and cycle rate are the required parameters.

Heat dissipation requirement is calculated as follows:

$$E = 1.7 \times WR^2 \times (N/100)^2 \times F$$

where:

$$E = \text{Heat (lb. ft./min.)}$$

WR^2 = Total reflected inertia at the clutch/brake shaft. Include the clutch/brake output inertia. (lb.ft.²)

N = Speed in revolutions per minute. (RPM)

F = Cycle rate in cycles per minute (CPM)

Compare the calculated heat generated in the application to the unit ratings using the heat dissipation curves. Select the appropriate unit that has adequate heat dissipation ability.

Heat Dissipation Curves

UM-50-C

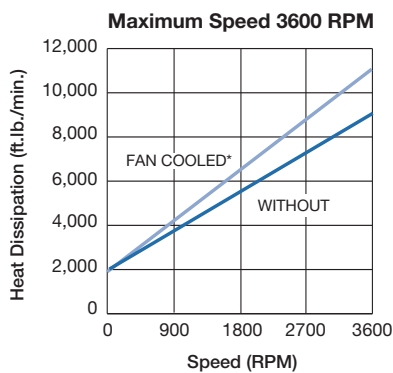

UM-180-C

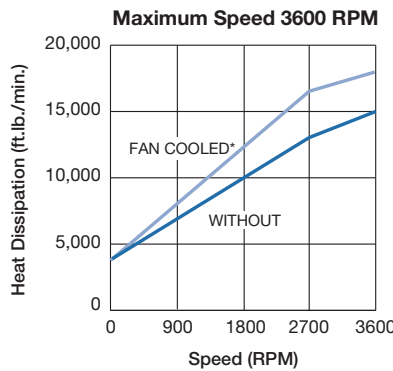

UM-210-C

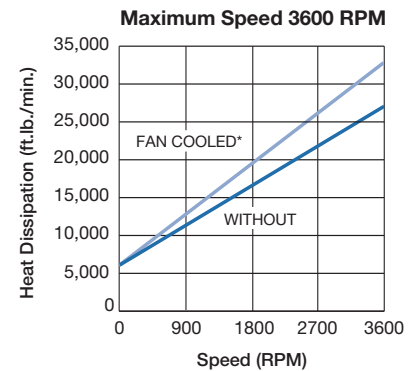

* Fan accessory kit available for 1020 configuration

b. Torque Sizing

For most applications, the correct size clutch/brake can be selected from the Horsepower vs. Shaft Speed chart located at the bottom of this page. Determine the motor horsepower and the RPM at the clutch/brake. The correct size unit is shown at the intersection of horsepower and shaft speed.

If the static torque requirements are known, refer to the technical ratings chart to select a unit.

For some applications, the torque requirement is determined by the time allowed to accelerate and decelerate the load. (This time is generally specified in milliseconds.) For these applications, it is necessary to determine the torque requirement based on load inertia and the time allowed for engagement.

The torque requirements are calculated as follows:

$$T = (WR^2 \times N) / (308 \times t)$$

where:

T = Average Dynamic Torque (lb. ft.)

WR^2 = Total reflected inertia at the clutch/brake shaft. Include the clutch/brake output inertia. (lb. ft.²)

N = Speed in revolutions per minute. (RPM)

t = Time allowed for the engagement (sec)

C-face Clutch/Power-on Brake Dynamic Torque Curves

Size 50

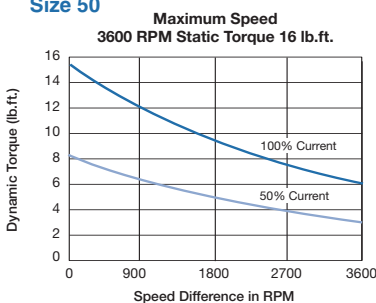

Size 100/180

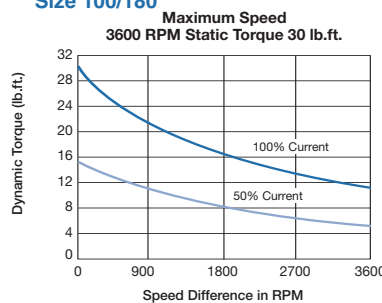

Size 210/215

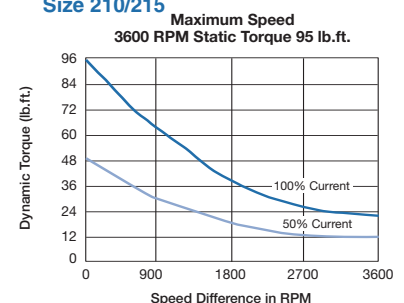

Specifications

UniModule Size	Shaft Dia.	Static Torque lb. ft.	Horsepower	Max. RPM	Voltage DC	NEMA Frame Size
UM50-C	5/8"	16	1/4-3/4	3600	6, 24 and 90	56C/48Y
UM180-C	7/8"	30	1-2	3600	6, 24 and 90	182C/143TC 184C/145TC
UM210-C	1-1/8"	95	3-5	3600	6, 24 and 90	213/182TC 215C/184TC

3. Select Accessories

Warner Electric UniModules can be fitted with several accessories to extend their capacity and ease of mounting.

a. Conduit Box

NEMA 4 and UL listed.



b. Mounting Brackets

Two styles of mounting brackets are available for simplified installation. The base mount is used with the 2030 configuration. A motor mount is also available and provides sturdy support for the 1020 and a motor.



c. Fan Kit (1020 only)

Extends the thermal capacity of any size UM. Mounts between motor and UM, includes shaft fan, guard and hardware.



4. Select Control

Warner Electric manufactures clutch/brake controls to meet several system functions including:

- On/Off
- Torque adjust
- Overexcitation
- Position loop

Many requirements beyond function can impact control selection. See the Controls Section on page 141 for complete information.

Part Numbers

Configuration	Model No.	Voltage	Part Number
1020 (Motor Clutch/Brake)	UM 50-1020-C	6	5370-273-077
		24	5370-273-078
		90	5370-273-079
	UM 180-1020-C	6	5370-273-073
		24	5370-273-074
		90	5370-273-075
	UM 210-1020-C	6	5371-273-035
		24	5371-273-036
		90	5371-273-037
2030 (Input Clutch/Brake)	UM 50-2030-C	6	5370-273-085
		24	5370-273-086
		90	5370-273-087
	UM 180-2030-C	6	5370-273-081
		24	5370-273-082
		90	5370-273-083
	UM 210-2030-C	6	5371-273-039
		24	5371-273-040
		90	5371-273-041

Accessories

Description	UM-C Size	Part Number
Conduit Box Conduit Control	All sizes	5370-101-042
	CBC-150-1 (120 V)	6004-448-001
	CBC-150-2 (220 V)	6004-448-002
Fan Kits 1020	50	5370-101-055
	180	5370-101-054
	210	5371-101-029
Base Mount Kits for 1020-C	50	5370-101-004
	180	5370-101-002
	210	5371-101-001
Motor Mount Kit for 2030-C	50	5370-101-010
	180	5370-101-012
	210	5371-101-012

How to Order

Motor or Reducer Mounted

Simply combine the size number with the configuration of the required UniModule. Specify voltage. See chart for specific part numbers. Order optional conduit box if desired.

Example

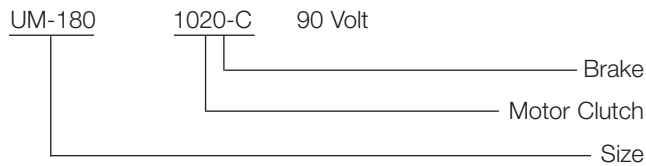

Base Mounted

Simply combine the size number with the configuration of the required UniModule. Specify voltage. See chart for specific part numbers. Order optional conduit box if desired.

Example

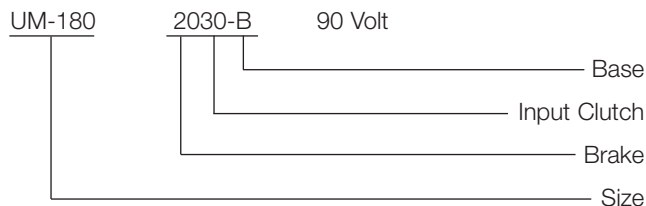

UM-1020-C Motor Clutch/Brake Combination

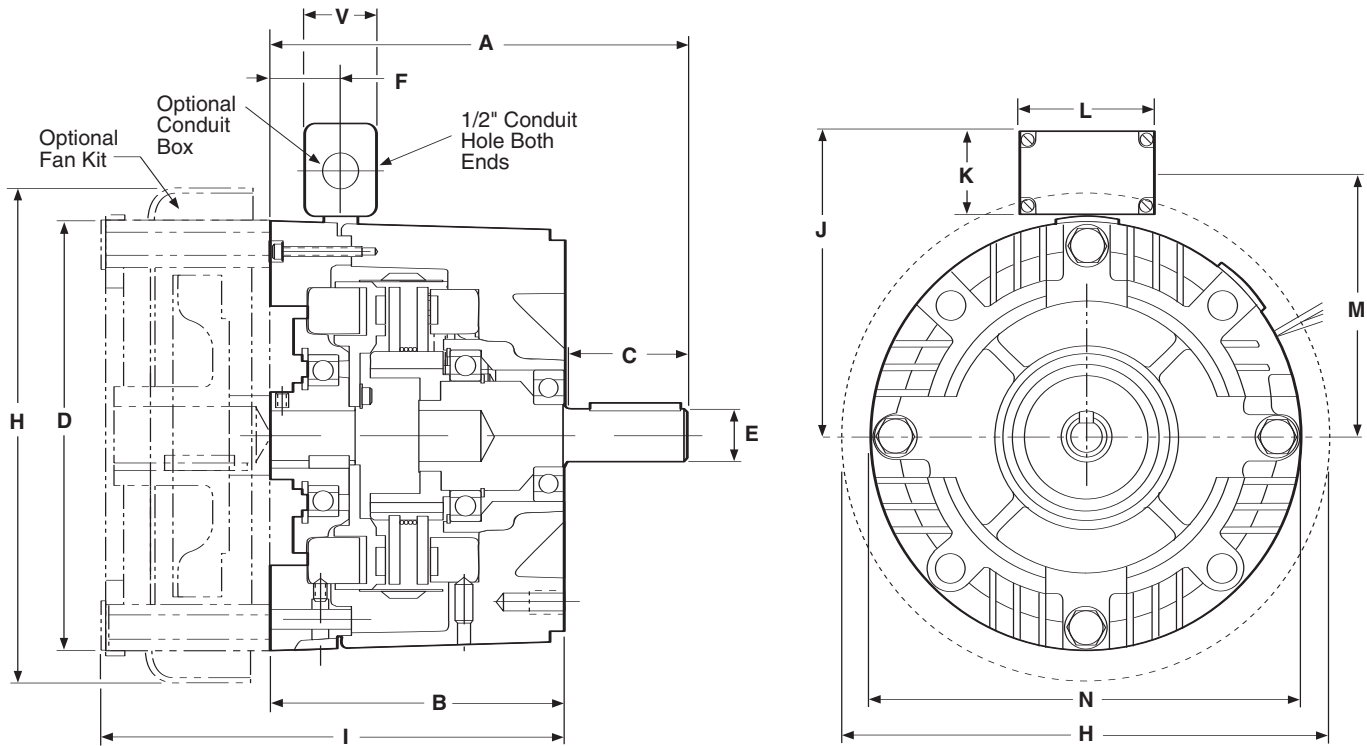

All dimensions are nominal, unless otherwise noted.

Size	A	B	C	D	E	F	G	H	I	J	K	L	M	N
50	6.750	4.844	1.813	6.750	.625	.937	2.203	7.687	7.274	5.531	2.188	3.125	4.438	6.688
180	6.828	4.844	1.812	6.750	.875	.937	2.203	7.687	7.274	5.531	2.188	3.125	4.438	6.688
210	9.391*	6.422*	2.500	9.250	1.125	1.125*	2.203	10.187	9.297	6.859	2.188	3.125	6.766	9.688

*Dimension includes the .500 thick adapter. Required for C-face mounting to a motor.

Specifications

UniModule Size	Shaft Dia.	Static Torque lb. ft.	Horsepower	Max. RPM	Voltage DC	NEMA Frame Size
UM50-C	.625	16	1/4-3/4	3600	6, 24 and 90	56C/48Y
UM180-C	.875	30	1-2	3600	6, 24 and 90	182C/143TC 184C/145TC
UM210-C	1.125	95	3-5	3600	6, 24 and 90	213/182TC 215C/184TC

For NEMA Standard Frame size, see page 137.

UM-2030-C Brake/Input Clutch Combination UM-2030-C-B Brake/Input Clutch Combination–Base Mounted

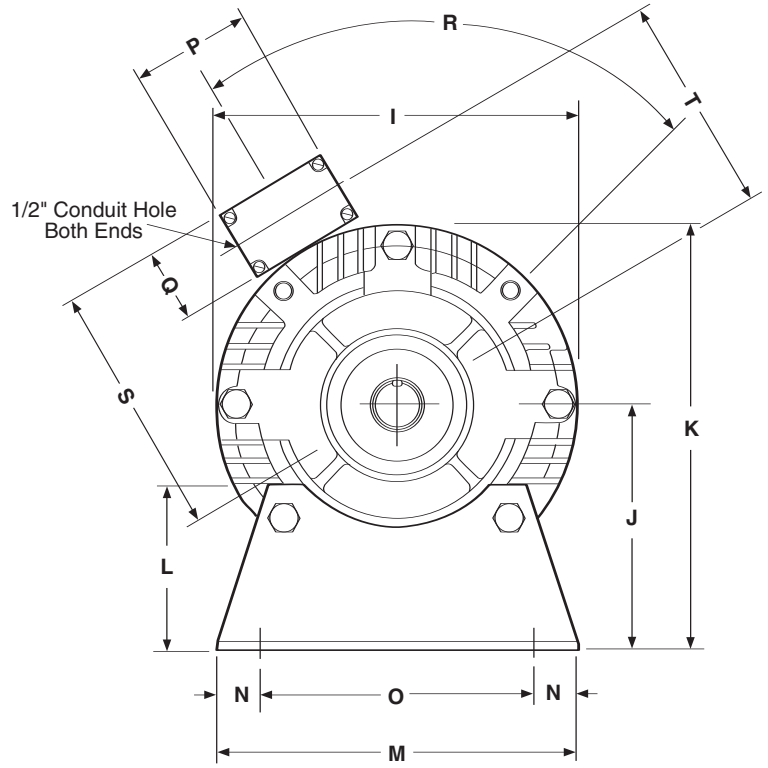
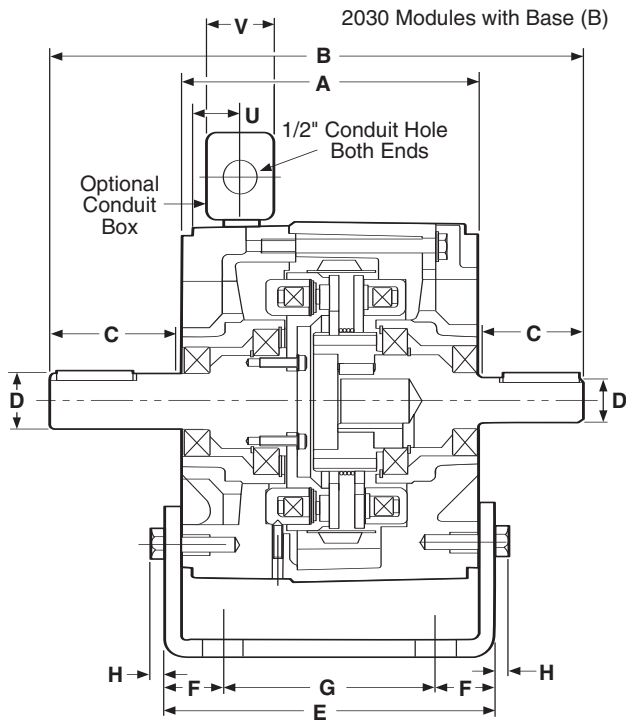

Note: Mounting base is optional and must be ordered separately.

All dimensions are nominal, unless otherwise noted.

Size	A	B	C Min.	D	E	F	G	H	I	J	K
50	5.719	9.516	1.813	.625	5.672	.844	4.000	.344	6.688	3.500	6.844
180	5.719	9.656	1.890	.875	5.672	.844	4.000	.344	6.688	4.500	7.844
210	7.719	12.969	2.500	1.125	8.203	1.094	6.000	.437	9.688	5.250	9.906

Size	L	M	N	O	P	Q	R	S	T	U	V
50	2.000	6.000	.500	5.000	3.125	2.188	75°	5.531	4.438	1.125	2.203
180	3.000	6.625	.500	5.000	3.125	2.188	75°	5.531	4.438	1.125	2.203
210	3.375	9.000	.625	7.750	3.125	2.188	70°	6.859	5.766	1.625	2.203

Specifications

UniModule Size	Shaft Dia.	Static Torque lb. ft.	Horsepower	Max. RPM	Voltage DC	NEMA Frame Size
UM50-C	.625	16	1/4-3/4	3600	6, 24 and 90	56C/48Y
UM180-C	.875	30	1-2	3600	6, 24 and 90	182C/143TC 184C/145TC
UM210-C	1.125	95	3-5	3600	6, 24 and 90	213/182TC 215C/184TC

For NEMA standard frame sizes, see page 137.

Contamination-Proof Design

Clean, quiet, operation. Nothing can get in, nothing can get out. Enclosed design eliminates damage to the working components. Prevents friction wear particles from escaping.

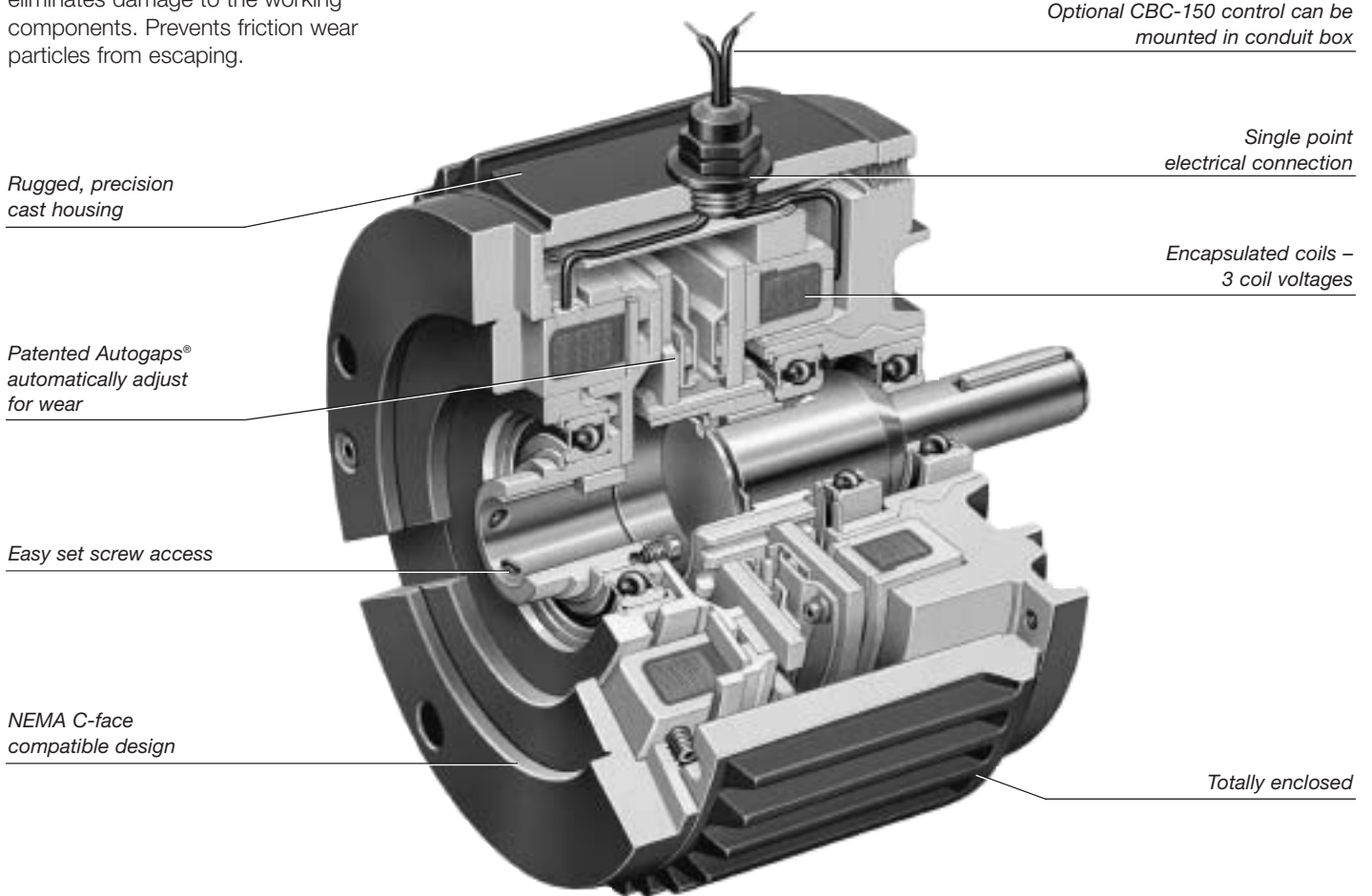

One piece, C-face package completely assembled and factory aligned. Mates easily with standard motors and reducers. Foot mounted package also available. Easy-to-install and no maintenance required.

Bolt-it-down, wire-it-up. UniModule is ready to go. Automatic adjustment for wear. Complete control capability.

Available with built-in power supply or used with separate controls for soft starts and stops . . . or for fast acting, accurate cycling.

- Factory burnished for out-of-box torque
- Superior heat transfer
- Dual endbell for easy repair
- Single point electrical connection
- Optional conduit box
- Optional integral control

Improved Hub Design/Autogap System

- Improved for longer spline life
- Autogap functions over broad current range
- New hub material

Two Versions

EUM Totally Enclosed

EUM (black) units are totally enclosed to keep wear particles in and exclude contaminants and are suitable for most industrial applications.

EUM-W Washdown Unit

EUM-W (white) units are ideal for applications that require frequent washing with high pressure spray systems.

EUM Series Clutch/Brakes and Clutch Combinations



Totally Enclosed Version

The Enclosed UniModule (EUM) packages the hardworking components from EM and UM products into a totally enclosed housing. This rugged housing keeps wear particles in and contaminants out and provides quiet operation. Pre-assembled and pre-aligned at the factory, and pre-burnished for rated torque directly out-of-box.

EUM (black) units are totally enclosed. They are suitable for most industrial applications and tolerate infrequent, light washing. They have aluminum endbells and a finned housing for rapid heat dissipation.

- Keeps contaminants out
- Keeps wear particles in
- Quiet operation
- Finned for heat dissipation
- UL listed when optional conduit box is installed



EUM-W Series Clutch/Brakes Washdown Unit

The washdown version of the EUM uses stainless steel shafting, USDA approved coating, corrosion resistant fasteners and special sealing accessories for use in washdown applications.

EUM-W (white) units are ideal for applications that require frequent washing with high pressure spray systems. Their smooth exterior does not allow food particles, or other contaminants, to get trapped and become host to bacteriological growth.

- USDA approved coating
- Stainless steel shafting
- Sealing (gaskets and plugs)
- Smooth exterior – easy washdown
- Corrosion resistant hardware
- Sealed/shielded bearings
- Baffled ventilation system
- Designed for IP65 enclosure requirements
- UL listed when conduit box is employed
- BISSC Certified

Applications and Mounting Configurations

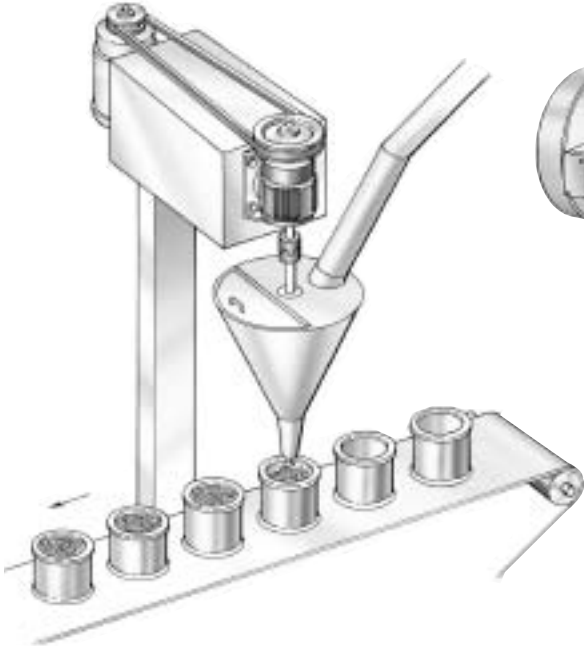

Auger Filler

The totally enclosed design of the EUM UniModule 2030 keeps wear particles in and contaminants out.

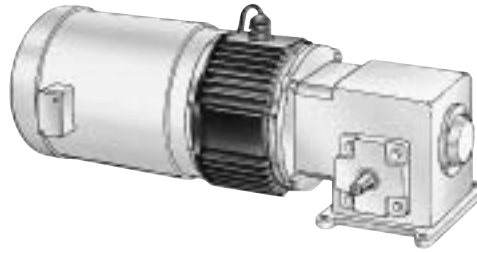

Enclosed UniModule 1040 clutch unit mounted between a C-face motor and reducer.

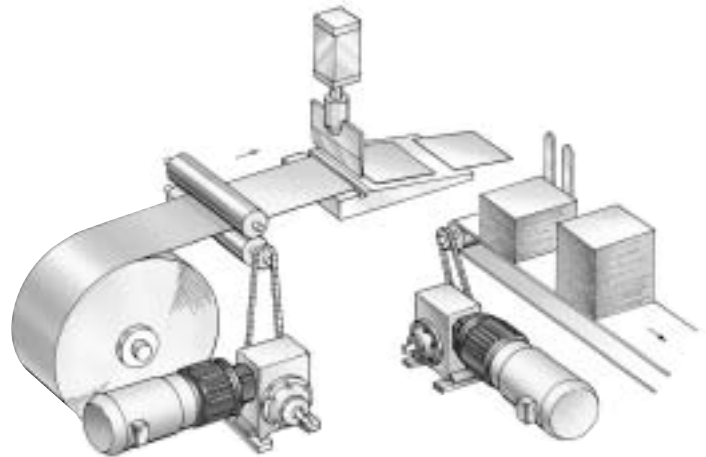

Sheet Cutter

The EUM UniModules 1020 provide quiet, clean, high cycle rate clutch/brake indexing.

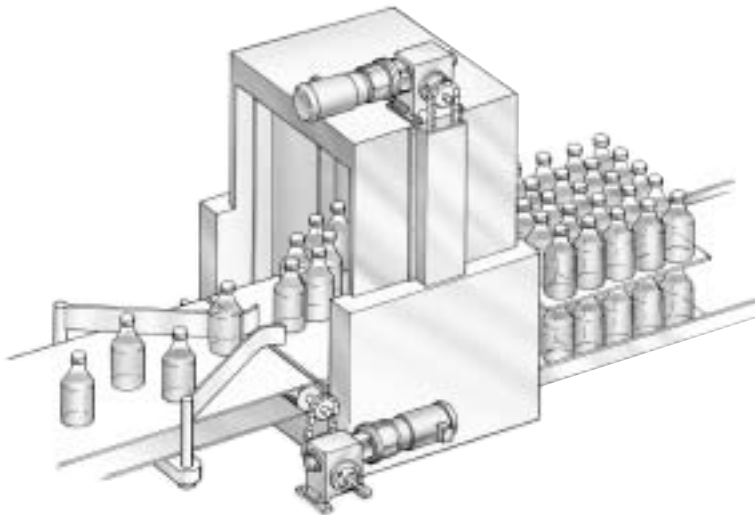

Stacking Operation

The clean design and corrosion resistance of EUM-W UniModules 1020 make them ideal for washdown applications.

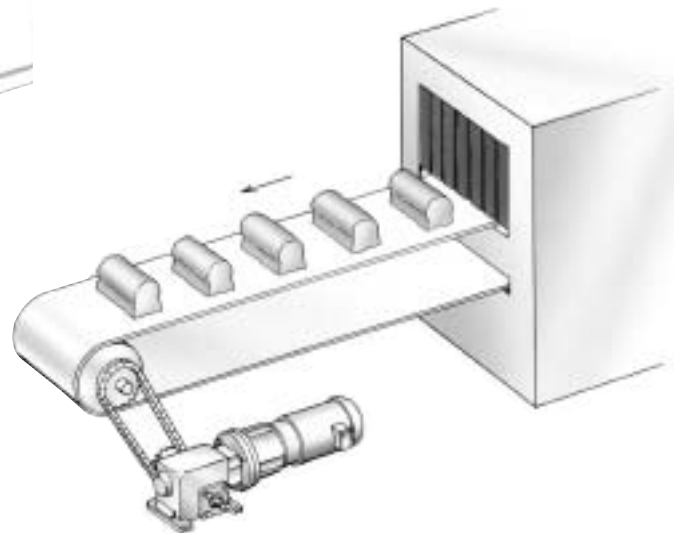

Food Handling

The EUM-W UniModule 1020 has an USDA approved coating which provides cleanliness and safe use in food processing operations.



Enclosed UniModule 2030 assembly base mounted for separate drive mounting.

EUM/EUM-W - Selection Procedure

Warner Electric EUM clutch/brake modules normally mount in either of two methods: NEMA C-face mounting or base mounting.

1. Select Configuration



a. NEMA C-face Mounting (1020 and 1040 Configurations)

Based on the NEMA C-face frame size of the prime mover, select the corresponding clutch/brake package size from the Frame Size Selection chart. Size 100 houses the components of the size 180 in a size 50 frame, while size 215 incorporates size 210 components.

Select either a 1020 or a 1040 (EUM only) configuration. The 1020 is a clutch/brake, while the 1040 is a clutch only. The 2030 configuration is a clutch/brake for base mounting.

Frame Size Selection

NEMA Frame Size	EUM Size
56C/48Y	EUM-50* EUM-100**
182C/143TC 184C/145TC	EUM-180
213C/182TC 215C/184TC	EUM-210
213TC/215TC	EUM-215

*For 56C/48Y C-frame motors 3/4 HP and smaller, the EUM-100 size may be used where extended life is desirable.

**The EUM-100 size is recommended for motors 1 HP and larger.

b. Base Mounting (2030 Configuration)



Enclosed UniModule assemblies may be mounted as separate drive units driven from the prime mover by V-belts, chain and sprockets, couplings, timing belts and other standard power transmission components.

Select the correct size 2030 package from the Horsepower vs. Shaft Speed chart by determining the motor horsepower and RPM at the module location. The correct size EUM is shown at the intersection of the HP and operating speed. For additional sizing information, refer to the technical sizing procedure (step 2).

2. Determine Technical Requirements

Technical considerations for sizing and selection are torque and heat dissipation. Each merits careful consideration, especially heat dissipation as over time, use in excessive temperature environments will have an adverse effect on bearing life and coil wire insulation integrity.

Compare the calculated torque requirement with the average dynamic torque ratings. Select a unit with adequate torque. If the unit selected on torque is different than the unit selected based on heat, select the larger size unit.

Two heat dissipation curves are shown. A fan kit accessory is available for use with these units.

Horsepower vs. Shaft Speed

HP	SHAFT SPEED AT CLUTCH (IN RPM)																		
	100	200	300	400	500	600	700	800	900	1000	1100	1200	1500	1800	2000	2400	3000	3600	
1/4																			
1/2																			
3/4																			
1																			
1-1/2																			
2																			
3																			
5																			
7-1/2																			
10																			

a. Heat Dissipation Sizing

Friction surfaces slip during the initial period of engagement and, as a result, heat is generated. The clutch/brake selected must have a heat dissipation rating greater than the heat generated by the application. Therefore, in high inertia or high cycle rate applications, it is necessary to check the heat dissipation carefully. Inertia, speed and cycle rate are the required parameters.

Heat dissipation requirement is calculated as follows:

$$E = 1.7 \times WR^2 \times (N/100)^2 \times F$$

where:

$$E = \text{Heat (lb. ft./min.)}$$

WR^2 = Total reflected inertia at the clutch/brake shaft. Include the clutch/brake output inertia. (lb.ft.²)

N = Speed in revolutions per minute. (RPM)

F = Cycle rate in cycles per minute (CPM)

Compare the calculated heat generated in the application to the unit ratings using the heat dissipation curves. Select the appropriate unit that has adequate heat dissipation ability.

Enclosed UniModule Heat Dissipation Curves

EUM 50

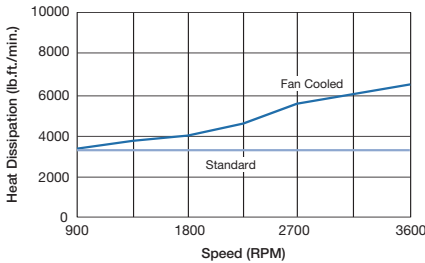

EUM 100/180

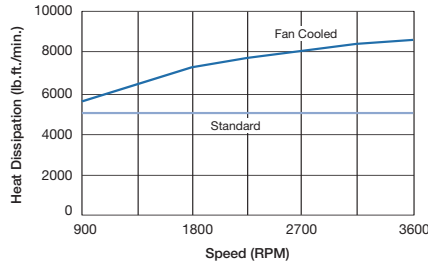

EUM 210/215 (fan not available for 215)

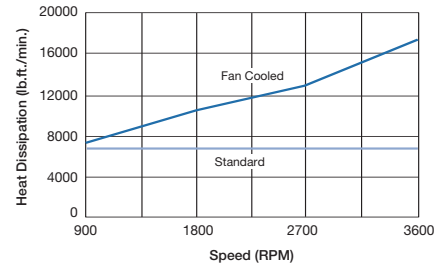

b. Torque Sizing

For most applications, the correct size clutch/brake can be selected from the Horsepower vs. Shaft Speed chart (located at the bottom of this page). Determine the motor horsepower and the RPM at the clutch/brake. The correct size unit is shown at the intersection of horsepower and shaft speed.

If the static torque requirements are known, refer to the technical ratings chart to select a unit.

For some applications, the torque requirement is determined by the time allowed to accelerate and decelerate the load. (This time is generally specified in milliseconds.) For these applications, it is necessary to determine the torque requirement based on load inertia and the time allowed for engagement.

The torque requirements are calculated as follows:

$$T = (WR^2 \times N) / (308 \times t)$$

where:

T = Average Dynamic Torque (lb. ft.)

WR^2 = Total reflected inertia at the clutch/brake shaft. Include the clutch/brake output inertia. (lb. ft.²)

N = Speed in revolutions per minute. (RPM)

t = Time allowed for the engagement (sec)

C-face Clutch/Power-on Brake Dynamic Torque Curves

EUM 50

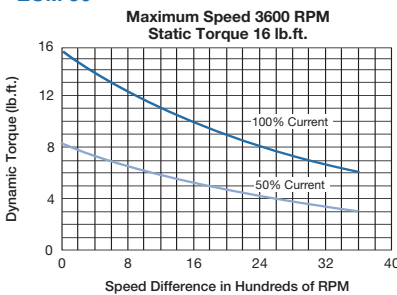

EUM 100/180

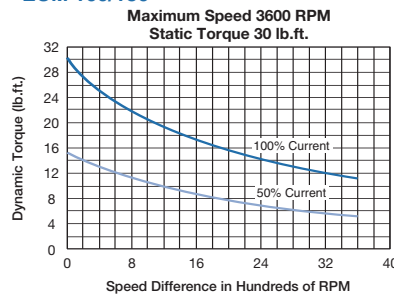

EUM 210/215

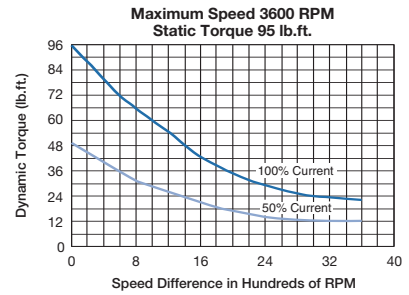

Specifications

UniModule Size	Shaft Dia.	Horsepower	Static Torque lb. ft.	Cycles per Min. @1750 RPM	Max. RPM	Voltage DC	NEMA Frame Size
EUM50	.625	1/4-3/4	16	125	3600	6, 24 or 90	56C/48Y
EUM100		1	30	90	3600	6, 24 or 90	
EUM180	.625	1-2	30	90	3600	6, 24 or 90	182C/143TC 184C/145TC
EUM210	1.125	3-5	95	37	3600	6, 24 or 90	213/182TC 215C/184TC
EUM215	1.375	7-1/2-10	95	37	3600	6, 24 or 90	213TC/215TC

3. Select Options

Warner Electric Enclosed UniModules can be fitted with several accessories to extend their capacity and ease of mounting.

a. Conduit Box

NEMA 4 and UL listed, available in standard and washdown versions.



b. Integral Control

The CBC-150 dual channel control fits into the cover of the conduit box. It is suitable for AC side switching (triac or relay) and includes high performance suppression.



c. Fan Kit (1020 only)

Extends the thermal capacity of an EUM. Mounts between motor and EUM, includes shaft, fan, guard and hardware. Available in standard black coating or food grade approved white coating.



d. Mounting Brackets

Two styles of mounting brackets are available for simplified installation. The base mount is used with the 2030 configuration. A motor mount is also available and provides sturdy support for a 1020 or 1040 combination with motor.

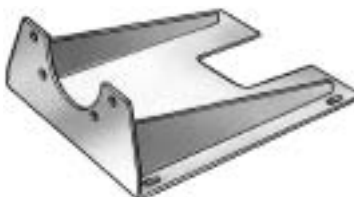

4. Select Control

Warner Electric manufactures clutch/brake controls to meet several system functions including:

- On/Off
- Torque adjust
- Over excitation
- Position loop

Many requirements beyond function can impact control selection. See the Controls Section on page 141 for complete information.

EUM-1020 Clutch/Brake Combination EUM-W-1020 Clutch/Brake Combination

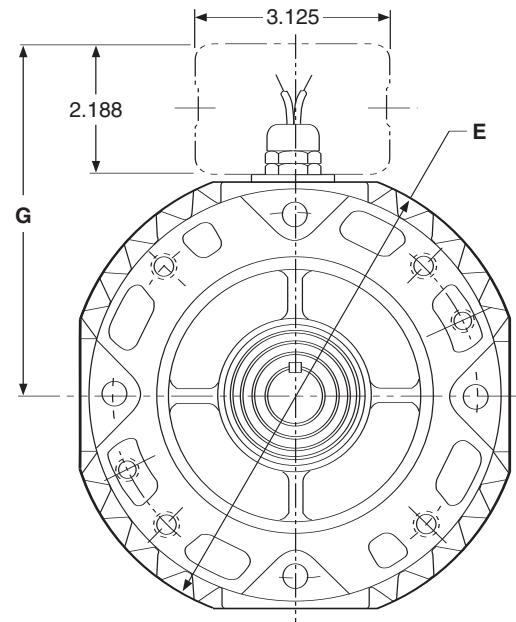
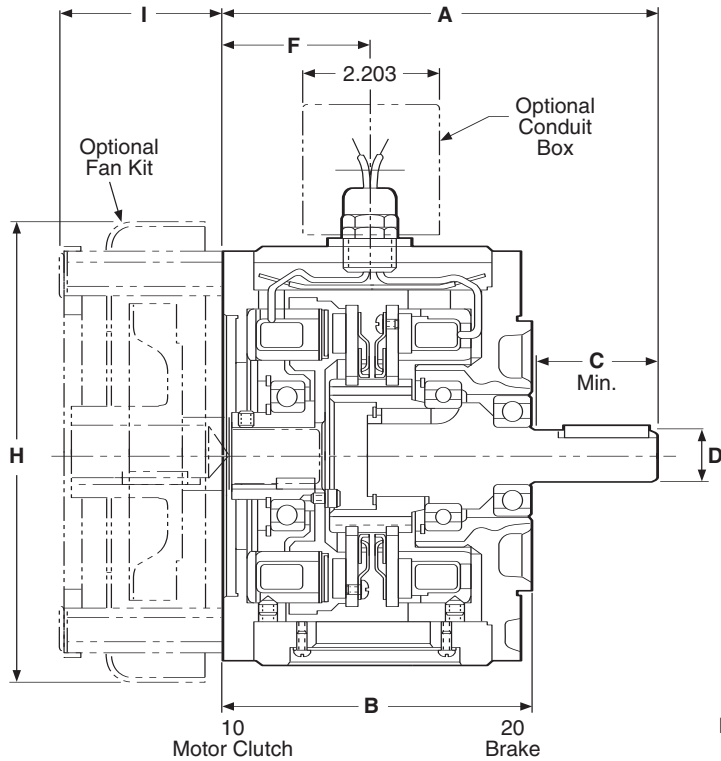

Note: Washdown Unimodules (EUM-W) do not have a finned housing.

All dimensions are nominal, unless otherwise noted.

Size	A	B	C	D	E		F	G	H	I
					EUM	EUM-W				
50/100	6.750	4.844	1.813	.625	7.270	6.915	2.427	5.936	7.687	2.430
180	6.828	4.844	1.890	.875	7.270	6.915	2.427	5.936	7.687	2.430
210	8.891	5.922	2.500	1.125	10.000	10.00	3.053	7.146	10.187	3.375
215	9.391	5.922	3.000	1.375	10.000	10.00	3.053	7.146	10.187	3.375

Specifications

UniModule Size	Shaft Dia.	Horsepower	Static Torque lb. ft.	CPM @1750 RPM	Max. RPM	Voltage DC	NEMA Frame Size
EUM50	.625	1/4-3/4	16	125	3600	6, 24 or 90	56C/48Y
EUM100	.625	1	30	90	3600	6, 24 or 90	56C/48Y
EUM180	.875	1-2	30	90	3600	6, 24 or 90	182C/143TC 184C/145TC
EUM210	1.125	3-5	95	37	3600	6, 24 or 90	213/182TC 215C/184TC
EUM215	1.375	7-1/2	95	37	3600	6, 24 or 90	213TC/215TC

For NEMA standard frame sizes, see page 137.

EUM-1040 Clutch Combination

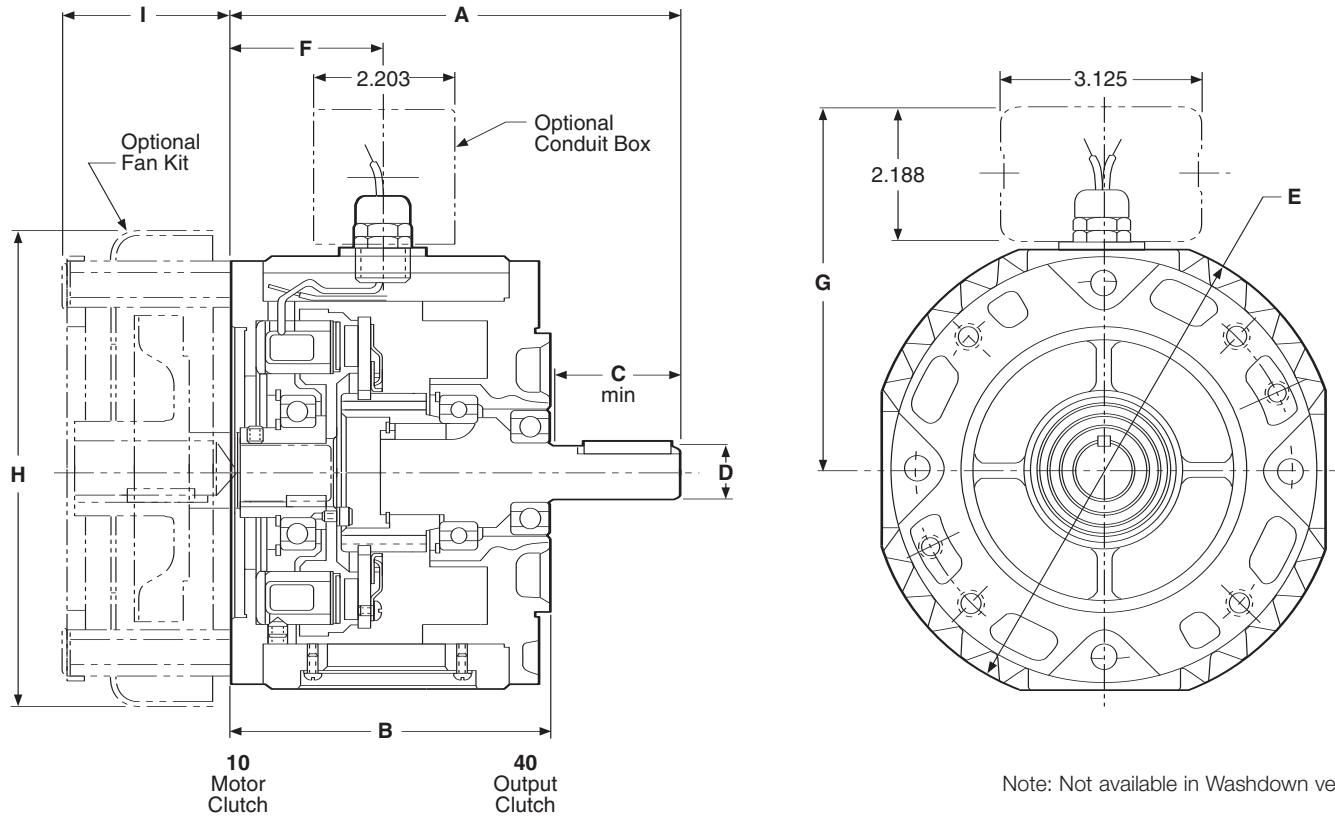

All dimensions are nominal, unless otherwise noted.

Size	A	B	C	D	E	F	G	H	I
50/100	6.750	4.844	1.813	.625	7.270	2.427	5.936	7.687	2.430
180	6.828	4.844	1.890	.875	7.270	2.427	5.936	7.687	2.430
210	8.891	5.922	2.500	1.125	10.000	3.053	7.146	10.187	3.375

Specifications

UniModule Size	Shaft Dia.	Horsepower	Static Torque lb. ft.	CPM @1750 RPM	Max. RPM	Voltage DC	NEMA Frame Size
EUM50	.625	1/4-3/4	16	125	3600	6, 24 or 90	56C/48Y
EUM100	.625	1	30	175	3600	6, 24 or 90	56C/48Y
EUM180	.875	1-2	30	175	3600	6, 24 or 90	182C/143TC 184C/145TC
EUM210	1.125	3-5	95	32	3600	6, 24 or 90	213/182TC 215C/184TC

For NEMA standard frame sizes, see page 137.

EUM-2030 Clutch/Brake Combination–Base Mounted EUM-W-2030 Clutch/Brake Combination–Base Mounted

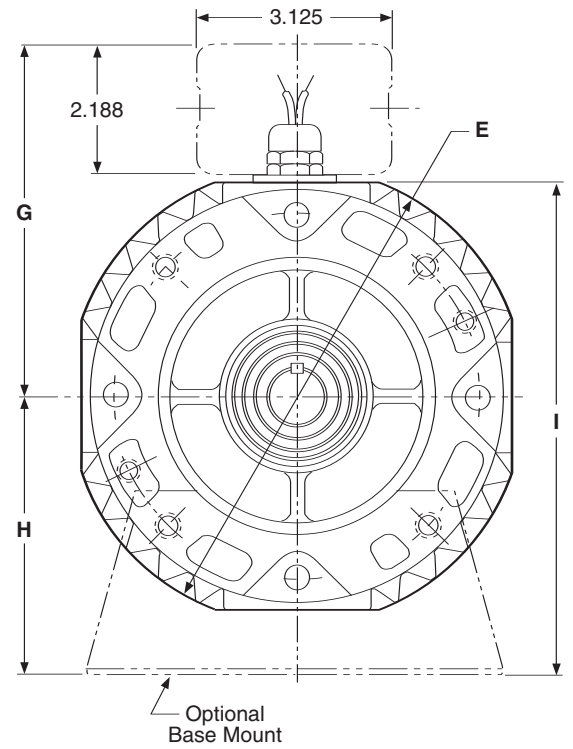
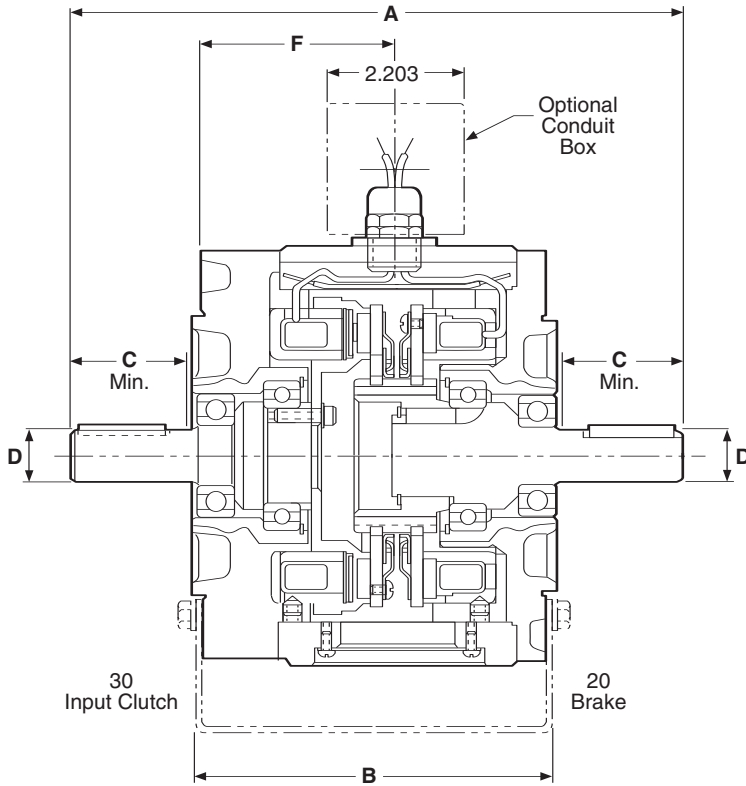

Note: Washdown UniModules (EUM-W) do not have a finned housing.

All dimensions are nominal, unless otherwise noted.

Size	A	B	C	D	E		F	G	H	I
					EUM	EUM-W				
50	9.516	5.672	1.813	.625	7.270	6.915	3.164	5.936	3.670	7.119
180	9.516	5.672	1.890	.875	7.270	6.915	3.164	5.936	4.484	8.119
210	12.969	8.260	2.500	1.125	10.000	10.00	4.514	7.146	5.234	10.234

Specifications

UniModule Size	Shaft Dia.	Horsepower	Static Torque lb. ft.	CPM @1750 RPM	Max. RPM	Voltage DC	NEMA Frame Size
EUM50	5/8"	1/4-3/4	16	125	3600	6, 24 or 90	56C/48Y
EUM100	5/8"	1	30	175	3600	6, 24 or 90	56C/48Y
EUM180	7/8"	1-2	30	175	3600	6, 24 or 90	182C/143TC 184C/145TC
EUM210	1-1/8"	3-5	95	32	3600	6, 24 or 90	213/182TC 215C/184TC

For NEMA standard frame sizes, see page 137.

Module Options

Warner Electric Enclosed UniModules can be fitted with several accessories to extend their capacity and ease of mounting.

Conduit Box

NEMA 4 and UL listed, available in standard and washdown versions.



Integral Control

The CBC-150 dual channel control fits into the cover of the conduit box. It is suitable for AC side switching (triac or relay) and includes high performance suppression.



Fan Kit (UM and EUM 1020 only)

Extends the thermal capacity of an EUM. Mounts between motor and EUM, includes shaft, fan, guard and hardware. Available in standard black coating or food grade approved white coating.



Mounting Brackets

Two styles of mounting brackets are available for simplified installation. The base mount is used with the 2030 configuration. A motor mount is also available and provides sturdy support for a 1020 or 1040 combination with motor.

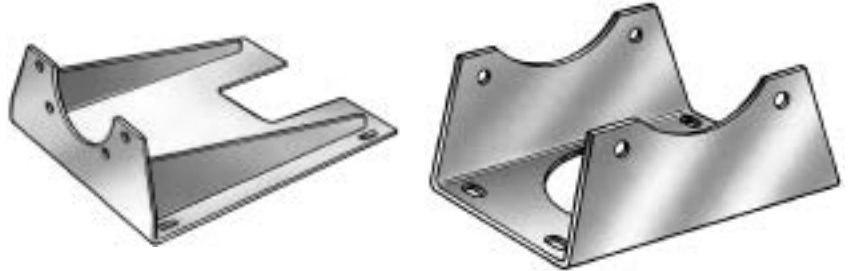

(Optional)

Motor Mount (M)

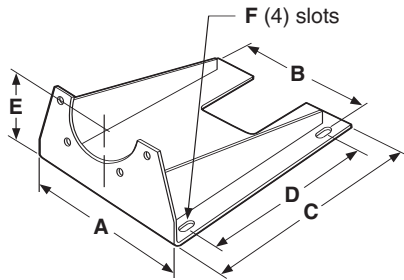

For use with 1020, 1040, 20, 20 FBB and 1020 FBC Combinations.

Size	A	B	C	D	E	F	Part No.
50/100	9.25	8.25	11.00	8.000	3.50	.797 x .406	5370-101-010
180	9.25	8.25	11.00	8.000	4.50	.797 x .406	5370-101-012/5370-101-047
210/215	11.50	10.50	12.00	9.000	5.25	.750 x .406	5371-101-012/5371-101-025

Base (B)

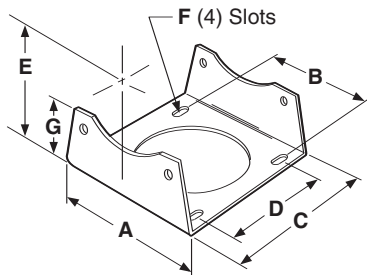

For use with 2030 and 3040 units.

Size	A	B	C	D	E	F	G	Part No.
50/100	6.000	5.000	5.672	4.000	3.500	.750 X .406	2.000	5370-101-004
180	6.625	5.000	5.672	4.000	4.500	.750 X .406	3.000	5370-101-002/5370-101-049
210/215	9.000	7.750	8.203	6.000	5.250	.750 X .531	3.385	5371-101-001/5371-101-026