

EC-375, EC-475, EC-650

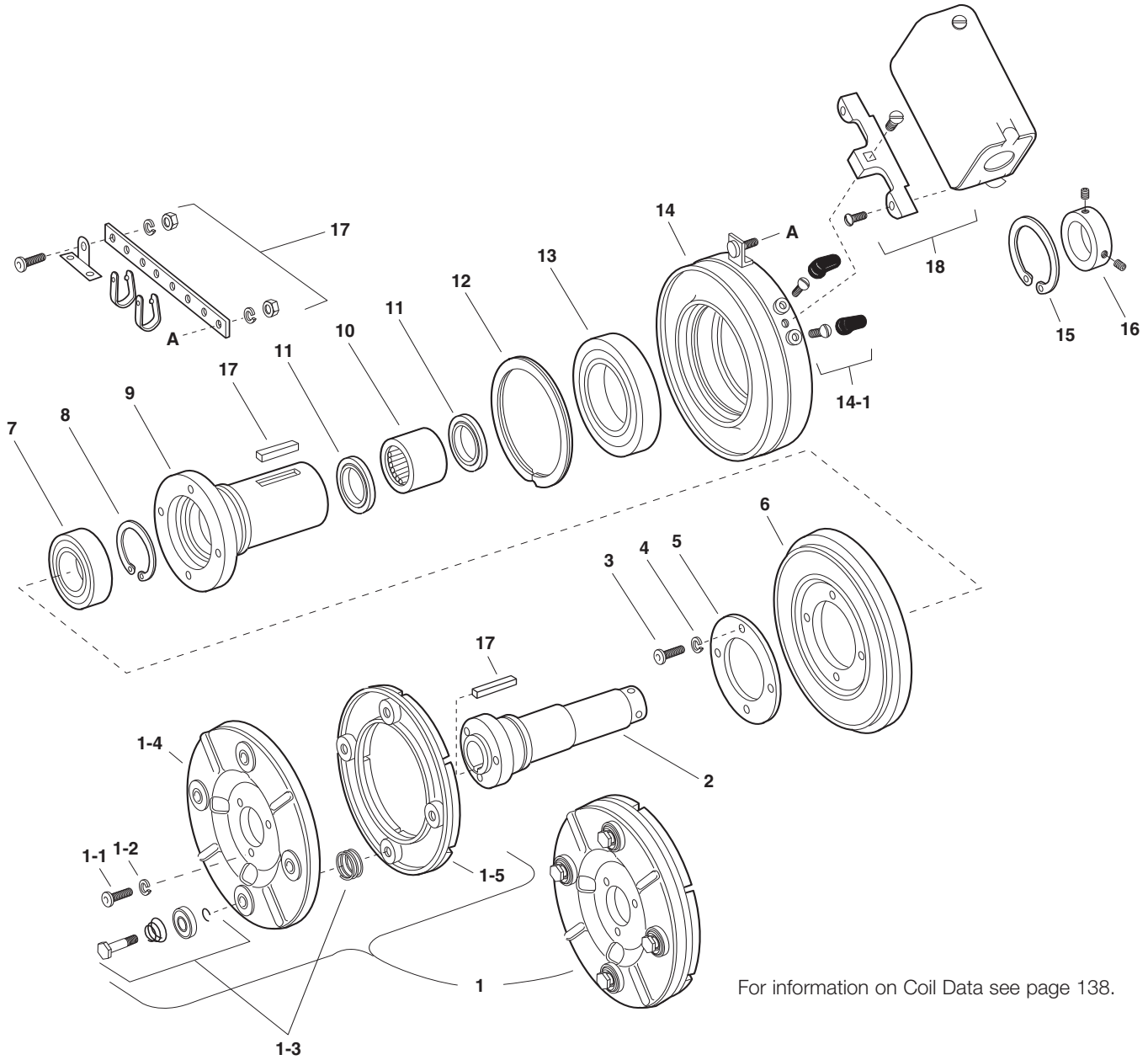

Electrical and Mechanical Data

Model Size	Voltage DC	Static Torque (lb. ft.)	Max. Speed RPM	Inertia-WR ² (lb. ft ²)			Total Inner Sleeve	Weight lbs.
				Armature & Carrier	Rotor	Outer Sleeve		
EC-375	6	16 lb. ft.	5000	.010	.018	.001	.001	4
	24	16 lb. ft.	5000	.010	.018	.001	.001	4
	90	16 lb. ft.	5000	.010	.018	.001	.001	4
EC-475	6	30 lb. ft.	4500	.072	.033	.006	.002	8
	24	30 lb. ft.	4500	.072	.033	.006	.002	8
	90	30 lb. ft.	4500	.072	.033	.006	.002	8
EC-650	6	95 lb. ft.	3600	.106	.202	.010	.013	18
	24	95 lb. ft.	3600	.106	.202	.010	.013	18
	90	95 lb. ft.	3600	.106	.202	.010	.013	18

Service Parts

Component Parts

Item	Description	EC-375		EC-475		EC-650	
		Part No.	Qty.	Part No.	Qty.	Part No.	Qty.
1	Armature & Carrier Assembly	5380-101-006	1	5181-101-003	1	5281-101-003	1
	1-1 Capscrew	797-1214	3	797-1214	3	797-0086	3
	1-2 Lockwasher	950-0102	3	950-0102	3	950-0102	3
	1-3 Autogap Accessory	5180-101-011	3	5181-101-010	4	5181-101-010	4
	1-4 Carrier	5380-295-002	1	5181-295-002	1	5281-295-002	1
	1-5 Armature	5180-111-002	1	5181-111-002	1	5281-111-002	1
2	Inner Sleeve		1		1		1
	1/2" Bore	803-0054					
	5/8" Bore	803-0055		803-0044			
	3/4" Bore			803-0042			
	7/8" Bore			803-0043			
	1" Bore					803-0047	
	1-1/8" Bore					803-0049	
1-1/4" Bore					803-0048		
	1-3/8" Bore					803-0050	
3	Screw	797-1050	6	797-1039	4	797-0083	4
4	Lockwasher	950-0105	6	950-0102	4	950-0103	4
5	Retainer Plate	748-0391	1	748-0393	1	748-0389	1
6	Rotor	5180-751-001	1	5181-751-001	1	5281-751-001	1
7	Ball Bearing	166-0149	1	166-0109	1	166-0110	1
8	Retainer ring	748-0017	1	748-0023	1	748-0002	1
9	Outer Sleeve	5180-104-001	1	5181-014-001	1	5281-104-001	1
10	Sleeve Bearing	166-0177	1	166-0179	1	166-0178	1
11	Oil Seal	795-0027	2	795-0028	2	795-0026	2
12	Retainer Ring	748-0101	1	748-0102	1	748-0104	1
13	Ball Bearing	166-0150	1	166-0110	1	166-0104	1
14	Field		1		1		1
	6 volt	5180-451-002		5181-451-002		5281-451-002	
	24 volt	5180-451-004		5181-451-004		5281-451-004	
	90 volt	5180-451-005		5181-451-005		5281-451-005	
	14-1 Terminal Accessory	5103-101-002	1	5103-101-002	1	5311-101-001	1
15	Retainer Ring	748-0018	1	748-0002	1	748-0004	1
16	Set Collar	266-0011	1	266-0012	1	266-0010	1
17	Accessory, W/Keys		1		1		1
	1/2" Bore	5180-101-001					
	5/8" Bore	5180-101-001		5181-101-001			
	3/4" Bore			5181-101-001			
	7/8" Bore			5181-101-002			
	1" Bore					5281-101-001	
	1-1/8" Bore					5281-101-001	
1-1/4" Bore					5281-101-001		
	1-3/8" Bore					5281-101-002	
18	Conduit Box	5200-101-010	1	5200-101-010	1	5200-101-010	1

These units when used with the correct Warner Electric conduit box, meets the standards of UL508 and are listed under guide care #NMTR, file #59164. These units are CSA Certified under file #LR11543.
Refer to Service Manual P-210.

EC-825

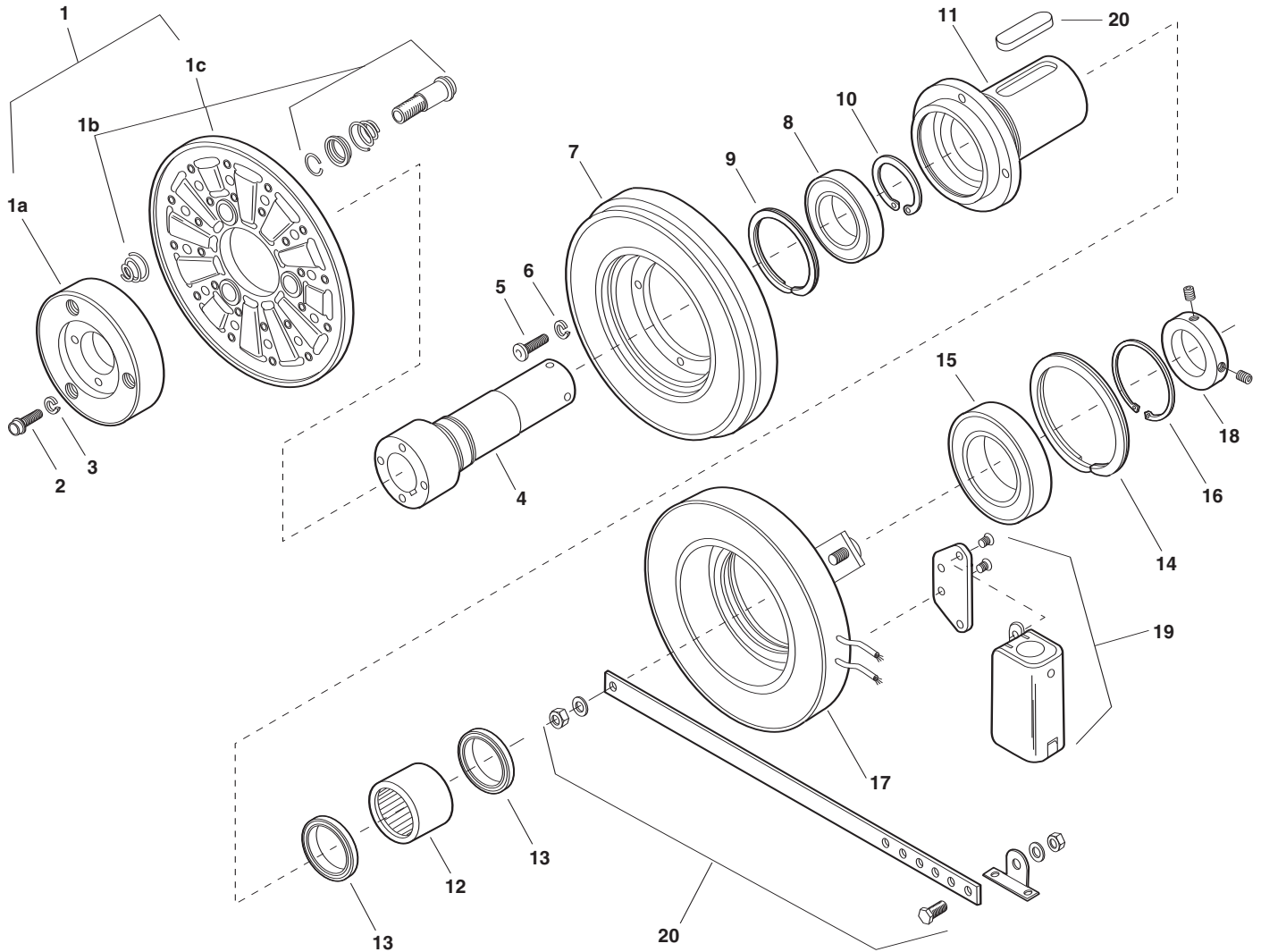

Component Parts

		EC-825	
Item	Description	Part No.	Qty.
1	Armature Assembly	5282-111-002	1
	1a Hub	540-1298	1
	1b Autogap Accessory	5201-101-068	3
	1c Armature	5282-111-001	1
2	Capscrew	797-0081	4
3	Lockwasher	950-0103	4
4	Inner Sleeve		1
	1-1/8" Bore	803-0069	
	1-1/4" Bore	803-0070	
	1-3/8" Bore	803-0071	
5	Capscrew	797-0086	4
6	Lockwasher	950-0103	4
7	Rotor Assembly	5282-751-001	1
8	Ball Bearing	166-0110	1
9	Retainer Ring	748-0102	1
10	Retainer Ring	748-0002	1
11	Rotor Adapter	5282-105-002	1

		EC-825	
Item	Description	Part No.	Qty.
12	Roller Bearing	166-0178	1
13	Oil Seal	795-0026	2
14	Retainer Ring	748-0104	1
15	Ball Bearing	166-0104	1
16	Retainer Ring	748-0004	1
17	Field		
	6 volt	5282-451-002	
	24 volt	5282-451-004	
	90 volt	5282-451-005	
18	Set Collar	266-0010	1
19	Conduit Box	5200-101-012	1
20	Mounting Accessory with Keys	5282-101-001	1

Refer to Service Manual P-210.

These units when used with the correct Warner Electric conduit box, meets the standards of UL508 and are listed under guide care #NMTR, file #59164. These units are CSA Certified under file #LR11543.

EC-1000, EC-1225

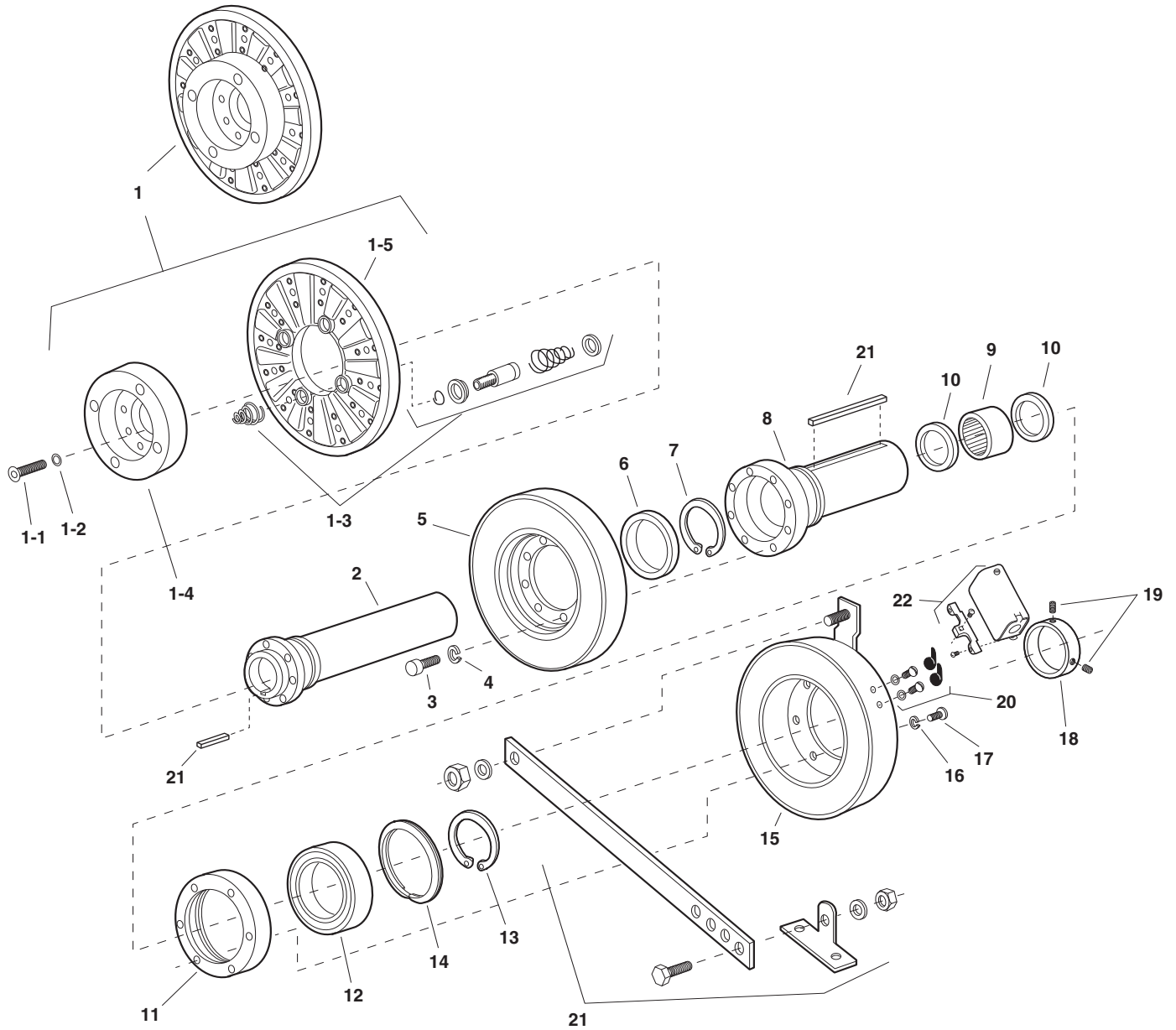

Service Parts

Warner Electric 800-234-3369

Component Parts

Item	Description	EC-1000		EC-1225	
		Part No.	Qty.	Part No.	Qty.
1	Armature & Carrier Assembly	5283-111-001	1	5284-111-001	1
	1-1 Capscrew	797-1163	6	797-1163	8
	1-2 Lockwasher	950-0111	6	950-0111	8
	1-3 Autogap Accessory	5201-101-008	3	5201-101-008	4
	1-4 Hub	540-1338	1	540-1340	1
	1-5 Armature	5302-111-013	1	5385-111-003	1
2	Inner Sleeve		1		1
	3/8" Bore	803-0027			
	1-1/2" Bore	803-0166			
	1-5/8" Bore	803-0028			
	1-5/8" Bore			803-0078	
	1-7/8" Bore			803-0030	
	2-1/8" Bore			803-0031	
3	Capscrew	797-0083	8	797-0416	8
4	Lockwasher	950-0103	8	950-0106	8
5	Rotor Assembly	5283-101-002	1	5284-101-006	1
6	Ball Bearing	166-0168	1	166-0170	1
7	Retainer Ring	748-0067	1	748-0503	1
8	Outer Sleeve	803-0025	1	803-0032	1
9	Roller Bearing	166-0180	1	166-0181	1
10	Oil Seal	795-0029	2	795-0033	2
11	Adapter Ring	748-0480	1	748-0466	1
12	Ball Bearing	166-0163	1	166-0163	1
13	Retainer Ring	748-0502	1	748-0502	1
14	Retainer Ring	748-0114	1	748-0114	1
15	Field		1		1
	6 volt	5283-451-002		5284-451-002	
	24 volt	5283-451-010		5284-451-010	
	90 volt	5283-451-003		5284-451-003	
16	Lockwasher	950-0355	6	950-0359	6
17	Capscrew	797-0083	6	797-0416	6
18	Set Collar	266-0015	1	266-0016	1
19	Set Screw	797-0468	2	797-0130	2
20	Terminal Accessory	5311-101-001	1	5311-101-001	1
21	Mounting Accessory with Keys		1		1
	1-3/8" Bore	5283-101-005			
	1-1/2" Bore	5283-101-009			
	1-5/8" Bore	5283-101-006		5284-101-007	
	1-7/8" Bore			5284-101-001	
	2-1/8" Bore			5284-101-002	
22	Conduit Box	5200-101-011	1	5200-101-011	1

Refer to Service Manual P-210.

These units when used with the correct Warner Electric conduit box, meets the standards of UL508 and are listed under guide care #NMTR, file #59164. These units are CSA Certified under file #LR11543.

EB-375, EB-475, EB-650

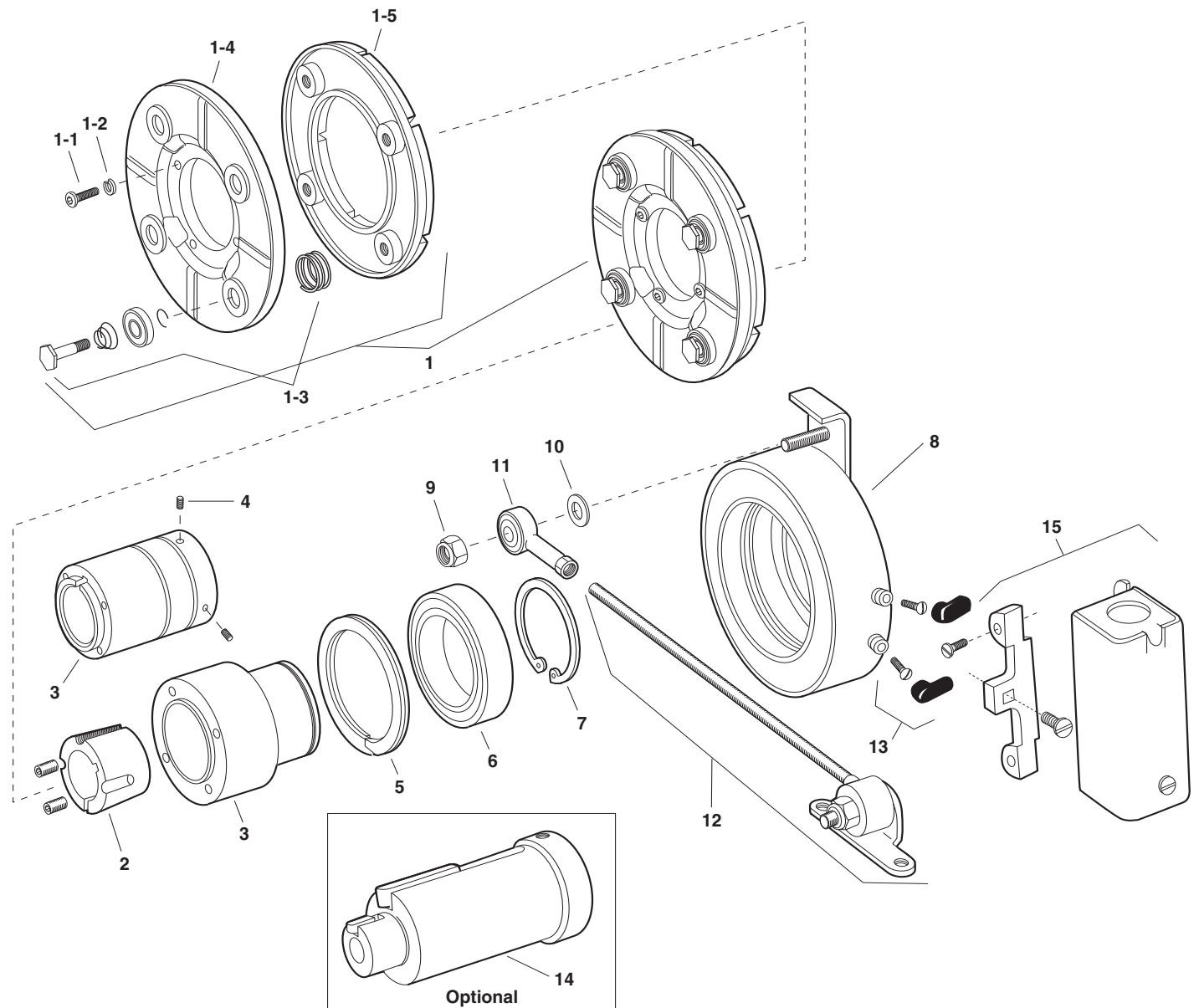

Component Parts

Item	Description	EB-375		EB-475		EB-650	
		Part No.	Qty.	Part No.	Qty.	Part No.	Qty.
1	Armature & Carrier Assembly	5380-101-006	1	5381-101-004	1	5382-101-005	1
	1-1 Capscrew	797-1214	3	797-1214	4	797-0086	4
	1-2 Lockwasher	950-0102	3	950-0102	4	950-0103	4
	1-3 Autogap Accessory	5180-101-011	3	5181-101-010	4	5181-101-010	4
	1-4 Carrier	5380-295-002	1	5381-295-003	1	5382-295-002	1
	1-5 Armature	5180-111-002	1	5181-111-002	1	5281-111-002	1
2	*Bushing			180-0410-180-0418 1/2" to 1" bore	1	180-0421-180-0435 1/2" to 1-3/8" bore	1
3	Hub		1	540-0524	1	540-0523	1
	1/2" Bore	540-0520					
	5/8" Bore	540-0519					
4	Set Screw		2				
	1/2" Bore	797-0368					
	5/8" Bore	797-0366					
5	Retainer Ring	748-0101	1	748-0102	1	748-0104	1
6	Ball Bearing	166-0150	1	166-0110	1	166-0104	1
7	Retainer Ring	748-0018	1	748-0002	1	748-0004	1
8	Magnet		1		1		1
	6 volt	5380-631-003		5381-631-003		5382-631-003	
	24 volt	5380-631-004		5381-631-004		5382-631-005	
	90 volt	5380-631-002		5381-631-002		5382-631-002	
9	Locknut	661-0050	1	661-0051	1	661-0004	1
10	Washer	950-0029	1	950-0026	1	950-0030	1
11	Rod End Bearing	166-0186	1	166-0187	1	166-0188	1
12	Torque Arm Rod Assembly	5380-112-001	1	5381-112-001	1	5382-112-001	1
13	Terminal Accessory	5311-101-001	1	5311-101-001	1	5311-101-001	1
14	Adapter (optional)		1		1		1
	5/8" Motor Shaft	5380-101-005					
	7/8" Motor Shaft	5380-101-004					
	1-1/8" Motor Shaft			5381-101-003			
	1-3/8" Motor Shaft					5382-101-003	
	1-5/8" Motor Shaft					5382-101-002	
15	Conduit Box	5200-101-010	1	5200-101-010	1	5200-101-010	1

*See page 235 for specific part numbers.

Refer to Service Manual P-211.

These units when used with the correct Warner Electric conduit box, meets the standards of UL508 and are listed under guide care #NMTR, file #59164. These units are CSA Certified under file #LR11543.

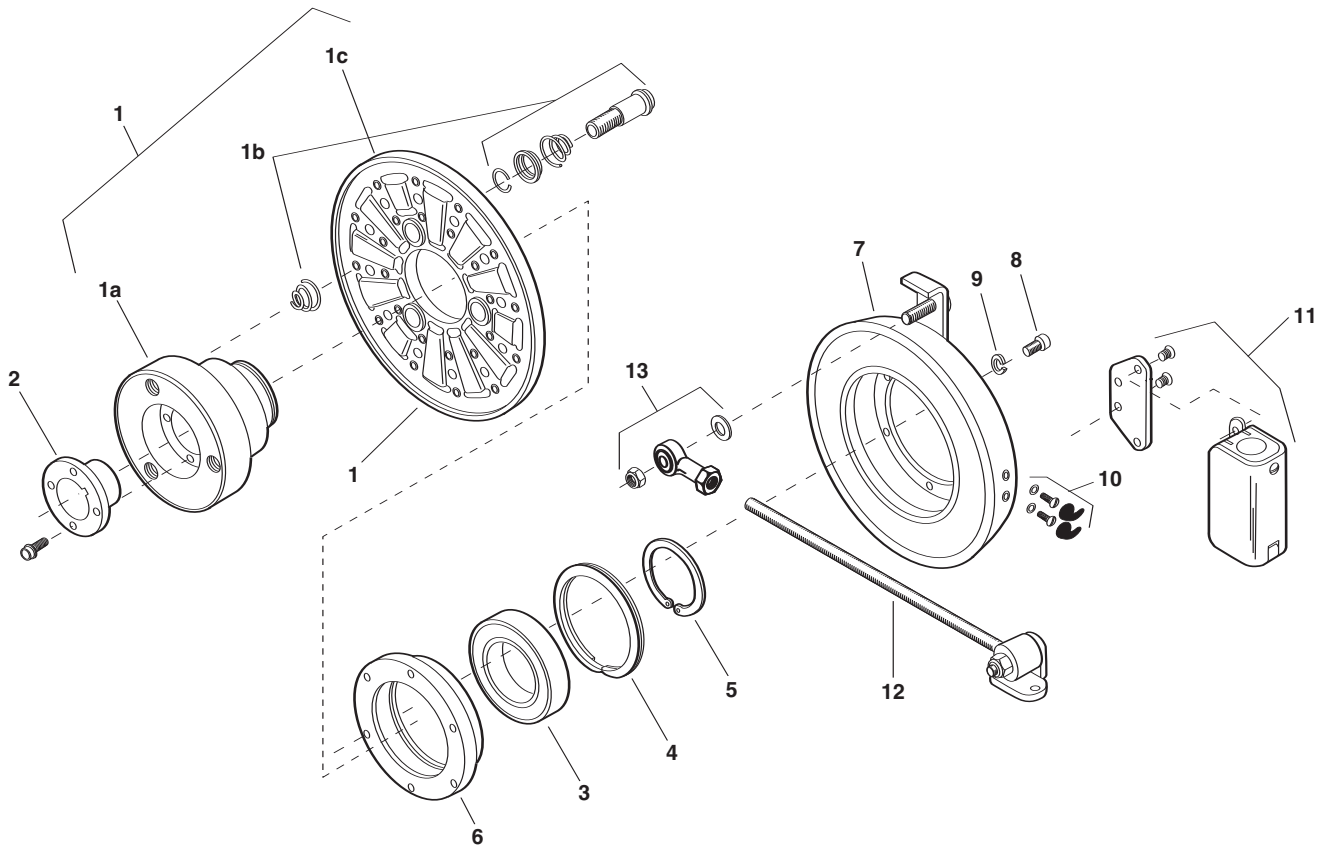

Component Parts

EB-825			
Item	Description	Part No.	Qty.
1	Armature Assembly	5383-111-001	1
	1a Hub	540-1299	1
	1b Autogap Assembly	5201-101-008	3
	1c Armature	5282-111-001	1
2	*Bushing	180-0002 to 180-0018 1/2" to 1-1/2" Bore	1
3	Ball Bearing	166-0168	1
4	Retainer Ring	748-0120	1
5	Retainer Ring	748-0584	1
6	Adapter Ring	748-0631	1

EB-825			
Item	Description	Part No.	Qty.
7	Magnet Assembly		1
	6 volt	5383-631-002	
	24 volt	5383-631-004	
	90 volt	5383-631-005	
8	Capscrew	797-0079	6
9	Lockwasher	950-0372	6
10	Terminal Accessory	5311-101-001	1
11	Conduit Box	5200-101-011	1
12	Torque Arm Rod Assembly	5382-112-001	1
13	Rod End Assembly	5382-101-007	1

*See page 235 for specific part numbers.
Refer to Service Manual P-211.

These units when used with the correct Warner Electric conduit box, meets the standards of UL508 and are listed under guide care #NMTR, file #59164.

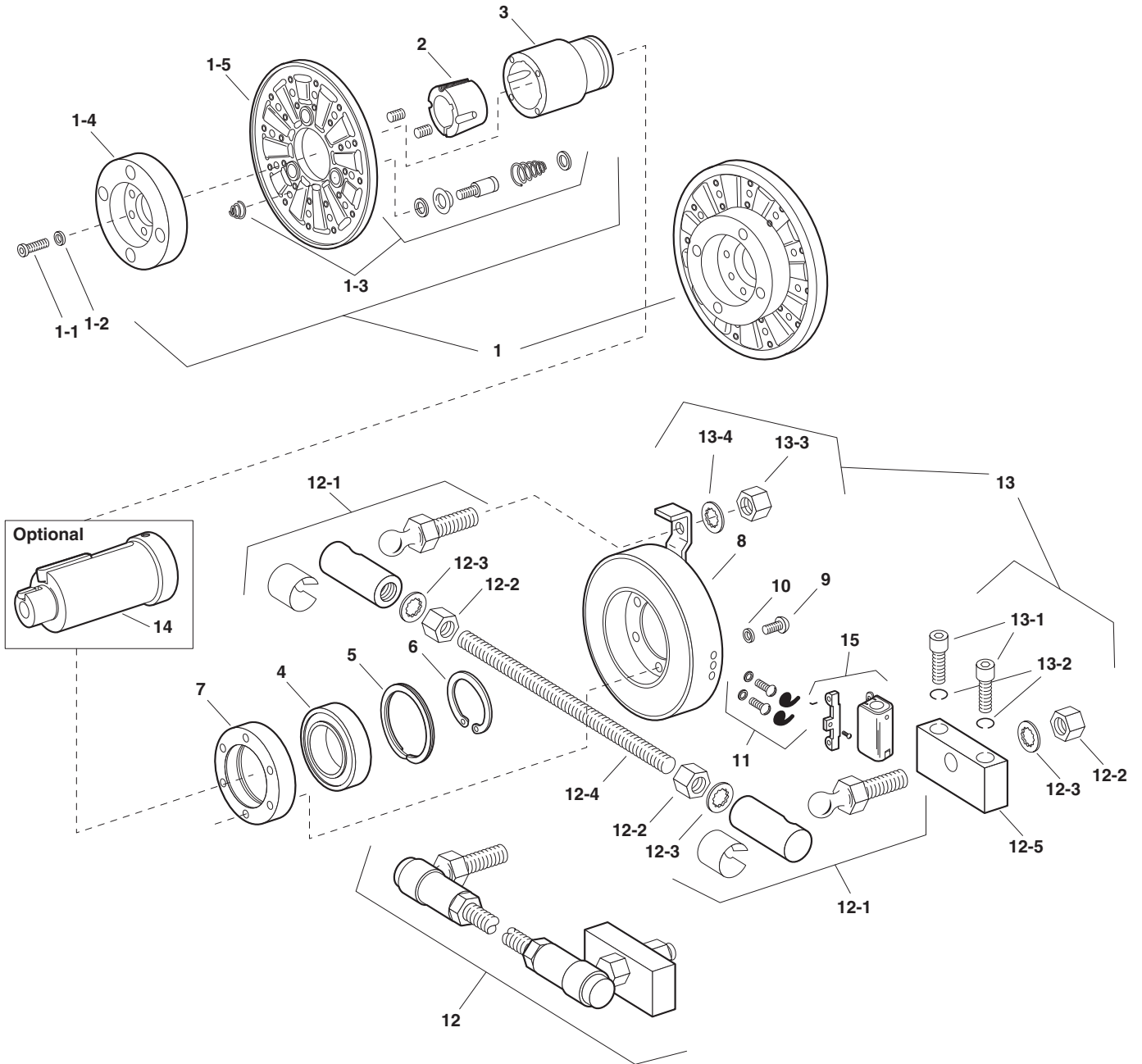

Component Parts

Item	Description	EB-1000		EB-1225	
		Part No.	Qty.	Part No.	Qty.
1	Armature & Carrier Assembly	5384-111-003	1	5385-111-004	1
	1-1 Capscrew	797-1163	6	797-1163	8
	1-2 Lockwasher	950-0111	6	950-0111	8
	1-3 Autogap Accessory	5201-101-008	3	5201-101-008	4
	1-4 Hub	540-1339	1	540-1341	1
	1-5 Armature	5302-111-013	1	5385-111-003	1
2	*Bushing	180-0131-180-0149 1/2" to 1-5/8" bore	1	180-0185-180-0217 1/2" to 2-1/2" bore	1
3	Hub	540-0579	1	540-0578	1
4	Ball Bearing	166-0164	1	166-0163	1
5	Retainer Ring	748-0116	1	748-0114	1
6	Retiner Ring	748-0501	1	748-0074	1
7	Adapter Ring	748-0467	1	748-0465	1
8	Magnet Assembly		1		1
	6 volt	5384-631-002		5385-631-002	
	24 volt	5384-631-009		5385-631-009	
	90 volt	5384-631-003		5385-631-003	
9	Capscrew	797-0416	6	797-0416	6
10	Lockwasher	950-0106	6	950-0106	6
11	Terminal Accessory	5311-101-001	1	5311-101-001	1
12	Torque Arm Rod Assembly	5385-757-001	1	5385-757-001	1
	12-1 Ball Joint	585-0001	2	585-0001	2
	12-2 Jam Nut	661-0012	3	661-0012	3
	12-3 Lockwasher	950-0114	3	950-0114	3
	12-4 Threaded Rod	756-0030	1	756-0030	1
	12-5 Bracket	174-0073	1	174-0073	1
13	Torque Arm Mounting Accessory	5385-101-001	1	5385-101-001	1
	13-1 Capscrew	797-0293	2	797-0293	2
	13-2 Lockwasher	950-0354	2	950-0354	2
	13-3 Jam Nut	661-0012	1	661-0012	1
	13-4 Lockwasher	950-0114	1	950-0114	1
14	Adapter (optional)		1		1
	1-5/8" Motor Shaft	5384-101-008			
	1-7/8" Motor Shaft	5384-101-007			
	2-1/8" Motor Shaft	5384-101-010		5385-101-008	
	2-3/8" Motor Shaft			5385-101-007	
15	Conduit Box	5200-101-011	1	5200-101-011	1

*See page 235 for specific part numbers.

Refer to Service Manual P-211.

These units when used with the correct Warner Electric conduit box, meets the standards of UL508 and are listed under guide care #NMTR, file #59164. These units are CSA Certified under file #LR11543.

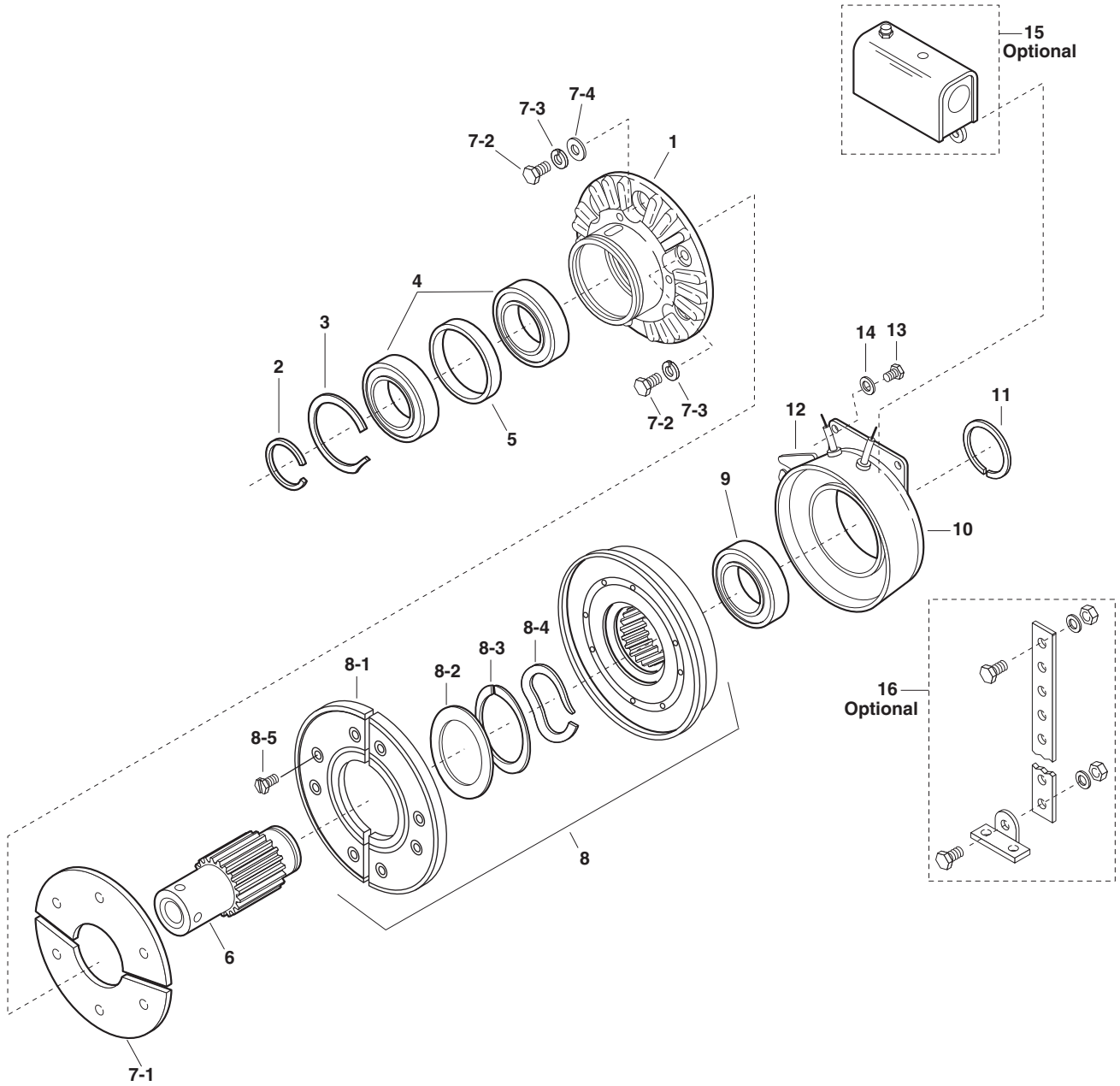

Component Parts

Item	Description	ATC-25		ATC-55		ATC-115	
		Part No.	Qty.	Part No.	Qty.	Part No.	Qty.
1	Armature Hub	540-0907	1	540-0852	1	540-0863	1
2	Retaining Ring	748-0732	1	748-0726	1	748-0737	1
3	Retaining Ring	748-0731	1	748-0728	1	748-0736	1
4	Bearing	166-0278	2	166-0277	2	166-0279	2
5	Spacer	807-0119	1	807-1061	1	807-1063	1
6	Splined Hub		1		1		1
	1/2" Bore	540-0910					
	5/8" Bore	540-0911					
	3/4" Bore	540-0912		540-1501			
	7/8" Bore	540-0913		540-1502			
	1" Bore			540-1503			
	1-1/8" Bore			540-1504		540-0857	
	1-1/4" Bore					540-0858	
1-3/8" Bore					540-0859		
1-1/2" Bore					540-0860		
*7-1	Armature	110-0220	1	110-0218	1	110-0223	1
*7-2	Screw	797-1519	4	797-1462	6	797-1463	6
*7-3	Lockwasher	950-0436	4	950-0355	6	950-0355	6
*7-4	Flatwasher			950-0023	2	950-0023	2
*8	Rotor	5161-751-001	1	5162-751-001	1	5163-751-001	1
8-1	Facing Assembly	5161-445-003	1	5162-445-003	1	5163-445-003	1
8-2	Retainer Plate					686-0108	1
8-3	Detent Ring	748-2031	1	748-2038	1	748-2020	1
8-4	Wave Spring	808-0404	1	808-0401	1	808-0384	2
8-5	Machine Screw	797-1389	8	797-1389	8	797-1389	8
*9	Bearing	166-0283	1	166-0284	1	166-0279	1
10	Field Assembly		1		1		1
	6 volts DC	5161-451-002		5162-451-002		5163-451-002	
	90 volts DC	5161-451-003		5162-451-003		5163-451-003	
	24 volts DC	5161-451-004		5162-451-004		5163-451-004	
*11	Retainer Ring	748-0018	1	748-0727	1	748-0737	1
12	Adapter					104-0300	2
13	Screw					797-1396	4
14	Lockwasher					950-0102	4
Optional Accessory Items							
15	Conduit box 100-1	5162-101-002	1	5162-101-002	1	5162-101-002	1
16	Restraining Arm Assembly	5162-101-004	1	5162-101-004	1	5163-101-004	1
Kit Items							
	* Clutch Rebuild Kit (includes items 7-1, 7-2, 7-3, 7-4, 8, 9, 11) Note: In some versions of this product, item 8 consists of a one (1) piece rotor.	5161-101-011	1	5162-101-011	1	5163-101-011	1
	Friction Face Replacement Kit For Clutches with Replaceable Friction Face Only	5161-101-007		5162-101-007		5163-101-007	
Mounting Accessory Kits (not shown)							
1	1/2" Bore - 3/4" Bore	5161-101-001					
1-1	Ring Retainer Ext.	748-0734	1				
1-2	Wire Retainer	742-0027	1				
1-3	Key	590-0104	1				
1-4	Setscrew	797-1393	2				
1	7/8" Bore	5161-101-002					
1-1	Ring Retainer Ext.	748-0734	1				
1-2	Wire Retainer	742-0027	1				
1-3	Key	590-0104	1				
1-4	Collar and Setscrew	266-0031	1				
1	3/4" Bore - 1" Bore			5162-101-001			
1-1	Ring Retainer Ext.			748-0725	1		
1-2	Wire Retainer			742-0026	1		
1-3	Key			590-0103	1		
1-4	Setscrew			797-1386	2		
1	1-1/8" Bore			5162-101-010			
1-1	Ring Retainer Ext.			748-0725	1		
1-2	Wire Retainer			742-0026	1		
1-3	Key			590-0103	1		
1-4	Setscrew			797-1077	2		
1-5	Collar			266-0032	1		
1	All bore sizes					5163-101-001	
1-1	Ring Retainer Ext.					748-0738	1
1-2	Wire Retainer					742-0026	1
1-3	Key					590-0105	1
1-4	Setscrew					797-1395	

ATB-25, ATB-55, ATB-115

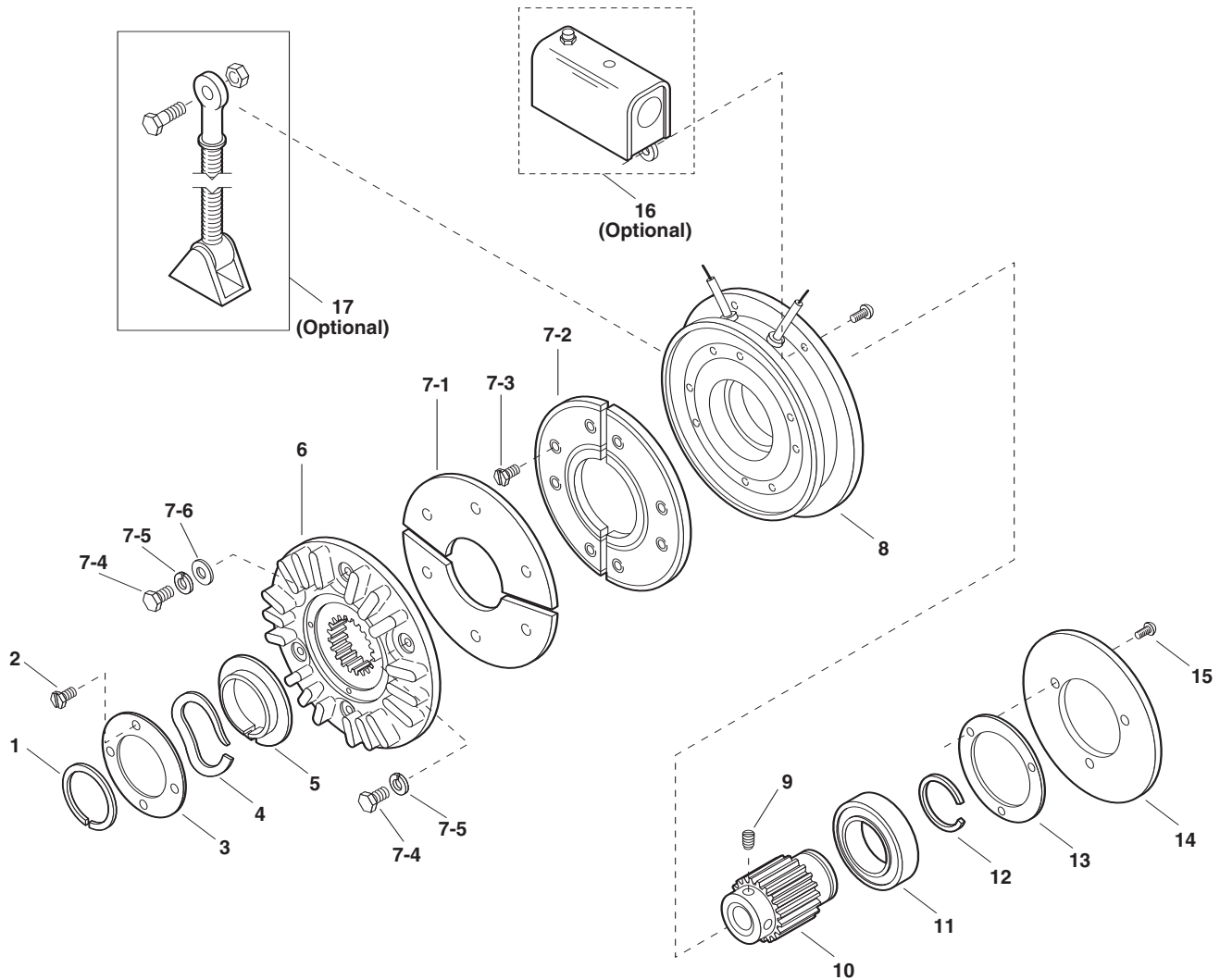

Electrical and Mechanical Data

Model Size	Voltage DC	Unit	Resistance (Ohms)	Current (Amps)	Watts	Coil Build Up (MMS)	Coil Decay (MMS)	Inertia*—WR ² (lb.ft. ²)	Max. RPM	Weight lbs.
25	6	Brake	1.37	4.38	26.3	145	9	.048	3600	8
	24		20.2	1.19	28.6	145	9	.048	3600	8
	90		290	.31	27.9	145	9	.048	3600	8
55	6	Brake	1.21	4.96	29.8	210	35	.173	3600	18
	24		19.6	1.22	29.3	210	35	.173	3600	18
	90		230	.39	35.2	210	35	.173	3600	18
115	6	Brake	1.02	5.91	35.4	150	45	.483	3600	28
	24		16.5	1.46	35	150	45	.483	3600	28
	90		182	.50	44.6	150	45	.483	3600	28

Component Parts

Item	Description	ATB-25		ATB-55		ATB-115	
		Part No.	Qty.	Part No.	Qty.	Part No.	Qty.
†1	Retainer	748-0018	1	748-0727	1	748-0737	1
†2	Screw	797-0321	3	797-0321	4	797-0321	4
3	Plate	686-0166	1	686-0162	1	686-0171	1
†4	Wave Spring	808-0404	1	808-0401	1	808-0384	2
†5	Detent Ring	748-2031	1	748-2038	1	748-2020	1
6	Armature Hub	540-0908	1	540-0851	1	540-0864	1
*†7-1	Armature	110-0220	1	110-0218	1	110-0223	1
*†7-2	Facing Assembly	5161-445-003	1	5162-445-003	1	5163-445-003	1
*†7-3	Screw	797-1389	6	797-1389	8	797-1389	8
*†7-4	Screw	797-1519	4	797-1462	6	797-1463	6
*†7-5	Lockwasher	950-0436	4	950-0355	4	950-0355	6
*†7-6	Flatwasher			950-0023	2	950-0023	2
8	Magnet Assembly		1		1		1
	6 volts DC	5191-631-002		5192-631-002		5193-631-002	
	24 volts DC	5191-631-004		5192-631-004		5193-631-004	
	90 volts DC	5191-631-003		5192-631-003		5193-631-003	
†9	Setscrew	797-1393	2	797-1386	2	797-1395	2
10	Splined Hub		1		1		1
	1/2" Bore	540-0901					
	5/8" Bore	540-0902					
	3/4" Bore	540-0903		540-1512			
	7/8" Bore	540-0904		540-1513			
	1" Bore			540-1514			
	1-1/8" Bore			540-1515		540-0866	
	1-1/4" Bore					540-0867	
	1-3/8" Bore					540-0868	1
1-1/2" Bore					540-0869	1	
†11	Ball Bearing	166-0283	1	166-0277	1	166-0279	1
†12	Retainer Ring	748-0018	1	748-0276	1	748-0737	1
13	Shim	801-1035	1	801-1034	1	801-1036	1
14	Backplate	686-0167	1	686-0163	1	686-0172	1
†15	Screw	797-1392	4	797-0437	3	797-0447	3
Optional Accessory Items							
16	Conduit box	5162-101-002	1	5162-101-002	1	5162-101-002	1
17	Torque Arm	5191-101-001	1	5192-101-001	1	5193-101-001	1
Kit Items							
*†18	Friction Face Replacement Kit (includes items 7-1, 7-2, 7-3, 7-4, 7-5, 7-6)	5161-101-007	1	5162-101-007	1	5163-101-007	1
†19	Brake Rebuild Kit (includes items, 1, 2, 4, 5, 7-1, 7-2, 7-3, 7-4, 7-5, 7-6, 9, 11, 12, 15)	5191-101-006	1	5192-101-006	1	5193-101-006	1

Refer to Service Manual P-218.

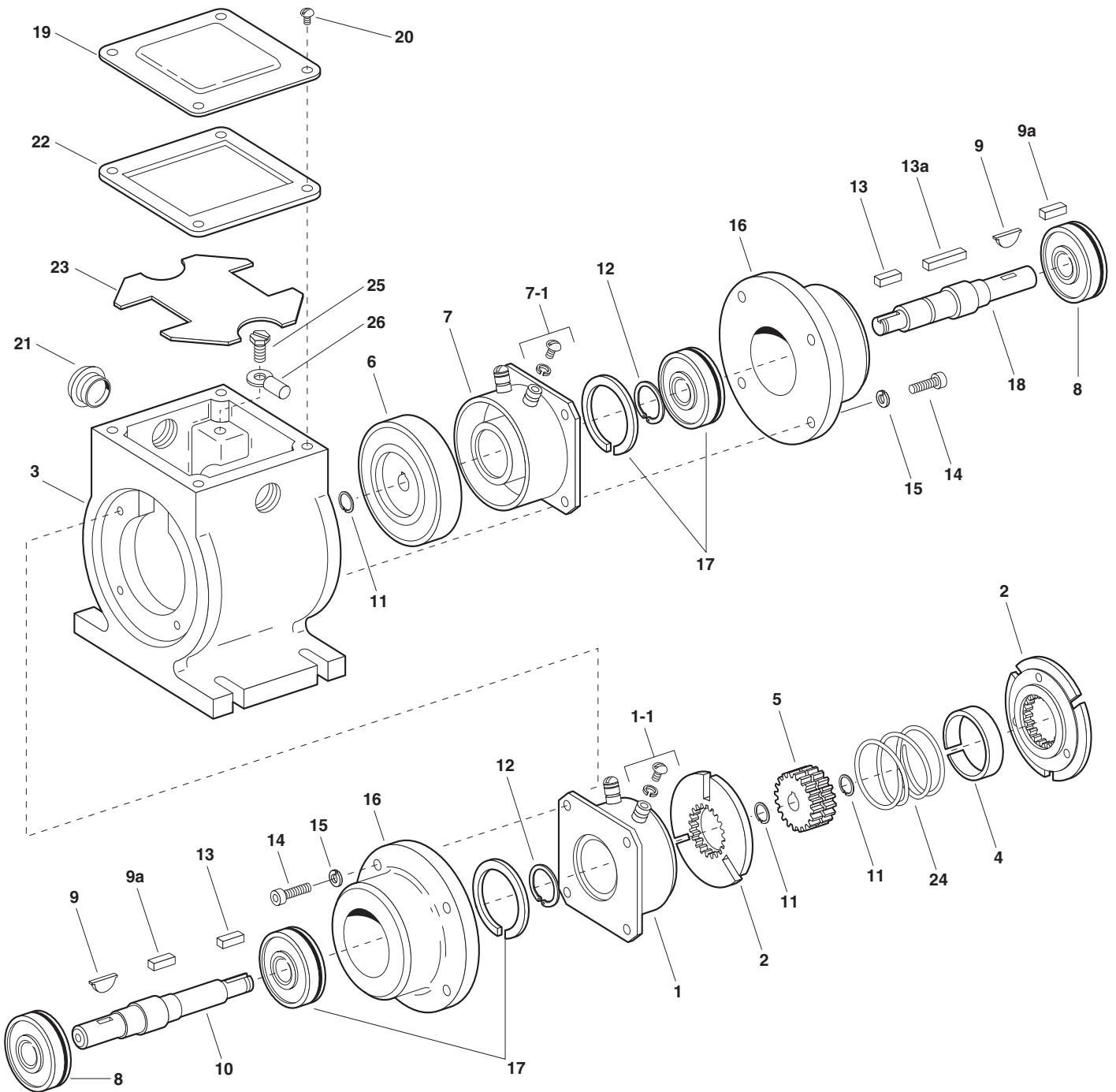

Component Parts

Item	Description	EP-170		EP-250		EP-400	
		Part No.	Qty.	Part No.	Qty.	Part No.	Qty.
1	Magnet Assembly		1		1		1
	6 volt	5375-631-003		5319-631-002		5115-631-002	
	24 volt	5375-631-005		5319-631-003		5115-631-003	
	90 volt	5375-631-007		5319-631-005		5115-631-004	
1-1	Terminal Accessory	†		5103-101-002	1	5103-101-002	1
2	Armature Assembly with Autogap	110-0111	2	5130-111-008	2	5131-111-001	2
3	Housing	535-0079	1	535-0082	1	535-0083	1
4	Armature Spacer	807-1021	1				
5	Splined Armature Hub	540-1250	1	540-1635	1	540-2034	1
6	Rotor Assembly	5603-751-029	1	5103-751-010	1	5104-751-034	1
7	Field Assembly		1		1		1
	6 volt	5603-451-047		5103-451-002		5104-451-032	
	24 volt	5603-451-049		5103-451-004		5104-451-033	
	90 volt	5603-451-051		5103-451-007		5104-451-034	
7-1	Terminal Accessory	†		5103-101-002	1	5103-101-002	1
8	Ball Bearing	166-0112	2	166-0114	2	166-0116	2
9	Key	590-0095	2	590-0014	2		
9a	Key					590-0016	2
10	Shaft, Brake	798-0136	1	798-0133	1	798-0131	1
11	Retainer Ring	748-0346	2	748-0347	2	748-0348	2
12	Retainer Ring	748-0042	2	748-0024	2	748-0022	2
13	Key	590-0089	2	590-0088	2	590-0087	1
13a	Key					590-0106	1
14	Capscrew	797-1219	8	797-1219	8	797-1220	8
15	Lockwasher	950-0351	8	950-0351	8	950-0355	8
16	Bearing Housing	535-0080	2	535-0081	2	535-0084	2
17	Ball Bearing, with Retainer	166-0111	2	166-0113	2	166-0115	2
18	Shaft, Clutch	798-0135	1	798-0134	1	798-0132	1
19	Cover Plate	686-1017	1	686-1018	1	686-1019	1
20	Screw	797-0015	4	797-0015	4	797-0015	4
21	Dust Plug	680-0037	2	680-0037	2	680-0037	2
22	Gasket	495-0003	1	495-0004	1	495-0005	1
23	Insulator	572-0573	1	572-0572	1	572-0574	1
24	Vertical Mfg. Spring Kit Optional	5603-101-001	1	5103-101-006	1	5104-101-005	1
25	Ground Screw		1	797-1245	1	797-1245	1
26	Terminal		1	900-0116	1	900-0016	1

†Lead wires used on EP-170.

These units meet the standards of UL508 and are listed under guide card #NMTR, file #59164. These units are CSA certified under file #LR11543.

EP-500

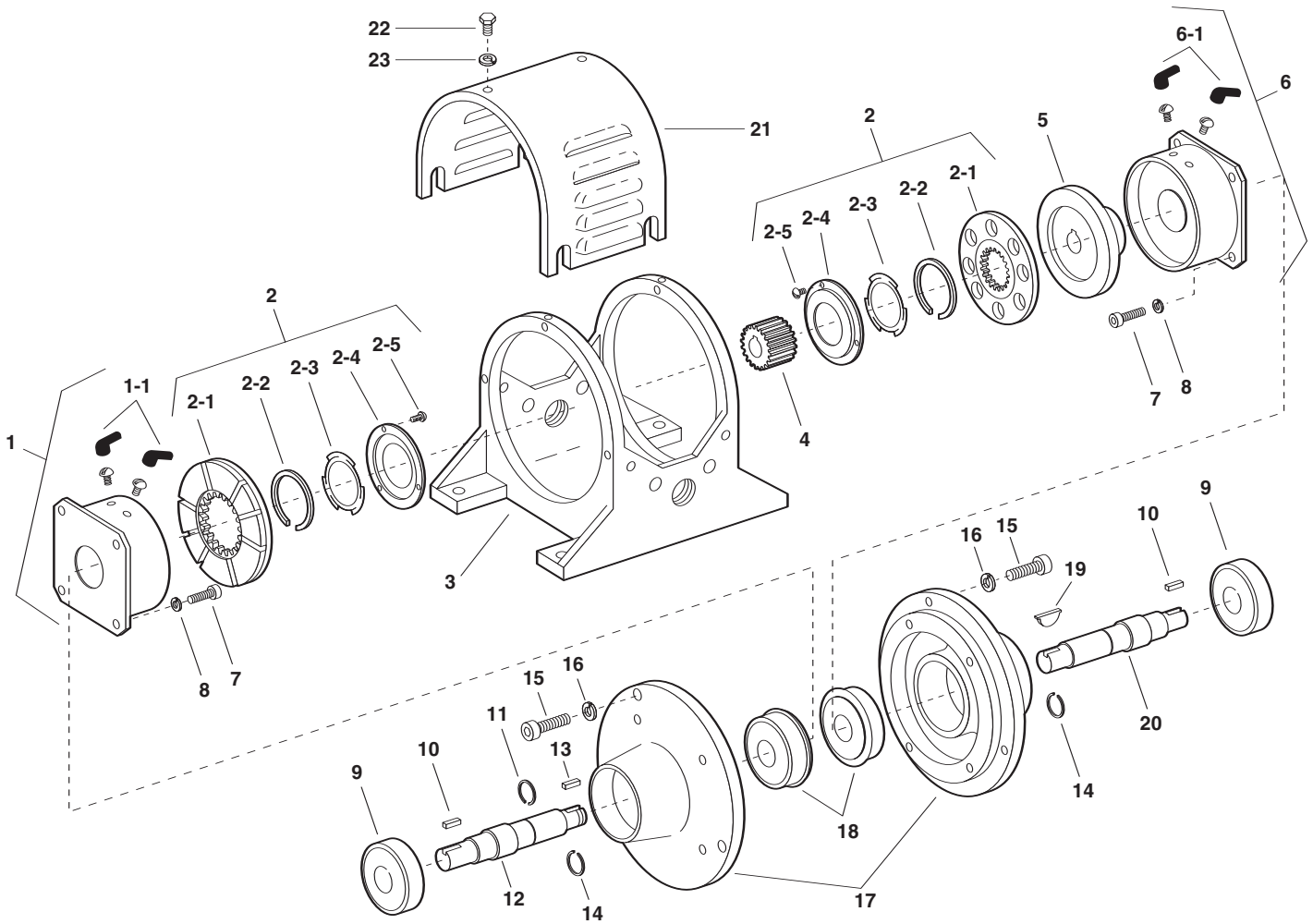

Component Parts

Item	Description	Part No.	Qty.
1	Magnet Assembly		1
	6 volt	5300-631-009	
	24 volt	5300-631-010	
	90 volt	5300-631-011	
1-1	Terminal Accessory	5311-101-001	1
2	Armature Assembly	5230-111-002	2
2-1	Armature	5230-111-001	2
2-2	Retainer Ring	748-0355	2
2-3	Spring	808-0412	2
2-4	Retainer Plate	748-0364	2
2-5	Screw	797-0028	12
3	Mounting Frame	174-0028	1
4	Splined Hub	540-2035	1
5	Rotor	5230-751-001	1
6	Field		1
	6 volt	5230-451-003	
	24 volt	5230-451-005	
	90 volt	5230-451-002	

Item	Description	Part No.	Qty.
6-1	Terminal Accessory	5311-101-001	1
7	Capscrew	797-0416	8
8	Lockwasher	950-0107	8
9	Ball Bearing	166-0125	2
10	Key	590-0020	2
11	Retainer Ring	748-0361	1
12	Shaft, Brake	798-0022	1
13	Key	590-0022	1
14	Retainer Ring	748-0335	2
15	Capscrew	797-0418	8
16	Lockwasher	950-0107	8
17	Endbell Housing	535-0010	2
18	Ball Bearing	166-0127	2
19	Key	590-0021	1
20	Shaft, Clutch	798-0028	1
21	Cover Drip Proof	287-0068	1
22	Capscrew	797-1214	6
23	Lockwasher	950-0102	6

Refer to Service Manual P-212.

These units meet the standards of UL508 and are listed under guide card #NMTR, file #59164. These units are CSA certified under file #LR11543.

Service Parts

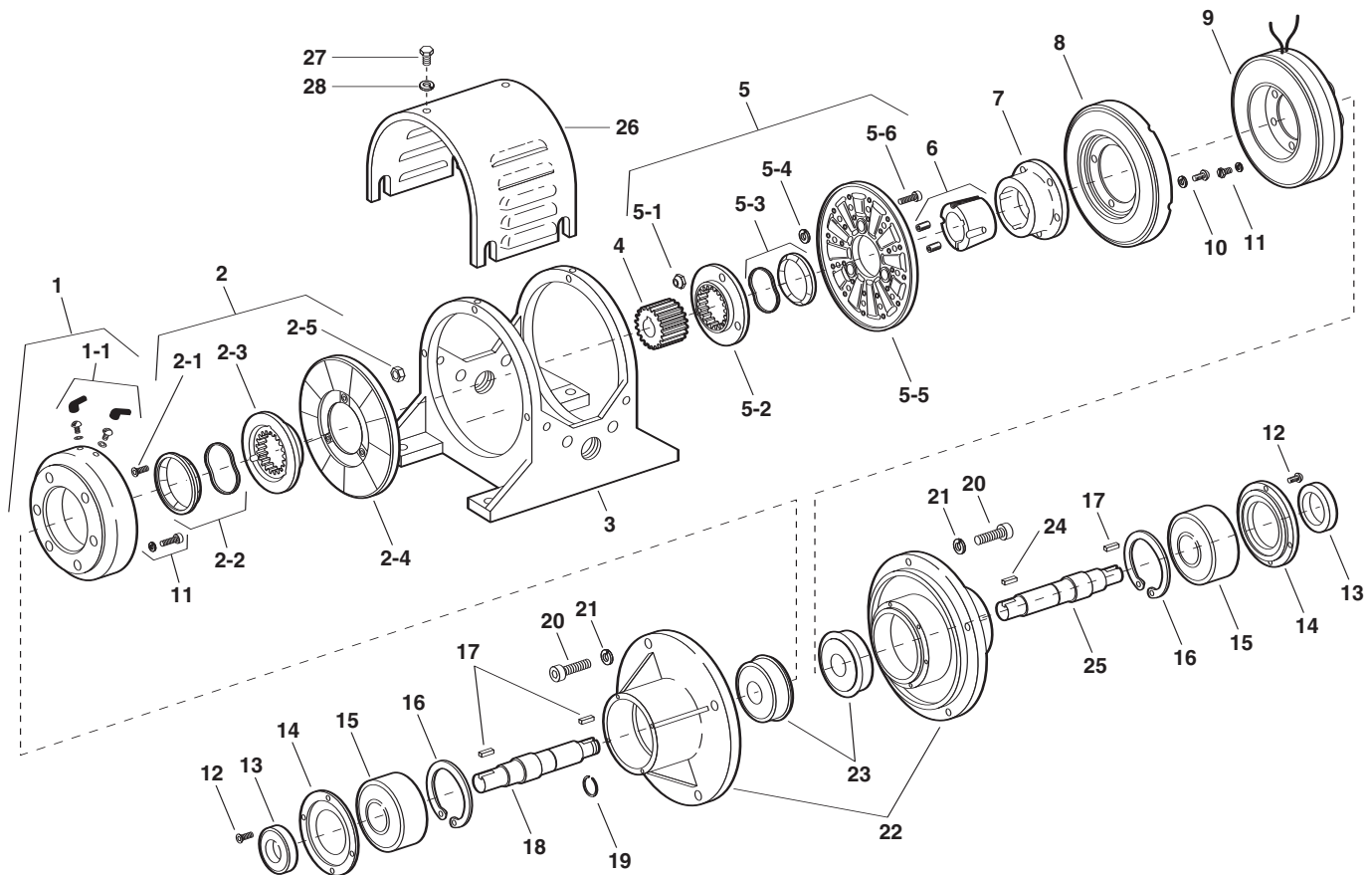

Component Parts

Item	Description	Part No.	Qty.
1	Magnet Assembly		1
	6 volt	5311-631-002	
	24 volt	5311-631-003	
	90 volt	5311-631-004	
2	Armature Assembly & Splined Adapter	5321-111-001	1
2-1	Screw	797-0272	3
2-2	Autogap Accessory	5321-101-006	1
2-3	Splined Adapter	104-0008	1
2-4	Armature	5321-111-022	1
2-5	Locknut	661-0004	3
3	Frame	174-0019	1
4	Splined Hub	540-0320	1
5	Armature & Splined Adapter	5201-111-001	1
5-1	Locknut	661-0004	3
5-2	Splined Adapter	104-0008	1
5-3	Autogap Accessory	5321-101-006	1
5-4	Spacer	748-0333	3
5-5	Armature	5321-111-022	1
5-6	Screw	797-0341	3
6	Bushing, 1-1/4" Bore	180-0113	1
7	Rotor Hub	540-0013	1
8	Rotor	5201-751-003	1
9	Field		1
	6 volt	5201-451-006	
	24 volt	5201-451-008	
	90 volt	5201-451-010	

Item	Description	Part No.	Qty.
10	Mounting Accessory	5201-101-007	1
11	Mounting Accessory	5321-101-001	2
12	Screw	797-1008	8
13	Oil Seal	795-0023	2
14	Retainer Plate	686-0031	2
15	Ball Bearing	166-0126	2
16	Retainer Ring	748-0336	2
17	Key	590-0019	3
18	Shaft, Brake	798-0019	1
19	Retainer Ring	748-0335	1
20	Capscrew	797-0351	8
21	Lockwasher	950-0354	8
22	Endbell Housing	535-0005	2
23	Ball Bearing	166-0125	2
24	Key	590-0018	1
25	Shaft, Clutch	798-0020	1
26	Cover, Drip Proof	287-0069	1
27	Capscrew	797-1214	6
28	Lockwasher	540-0102	6

Refer to Service Manual P-212.
 These units meet the standards of UL508 and are listed under guide card #NMTR, file #59164. These units are CSA certified under file #LR11543.

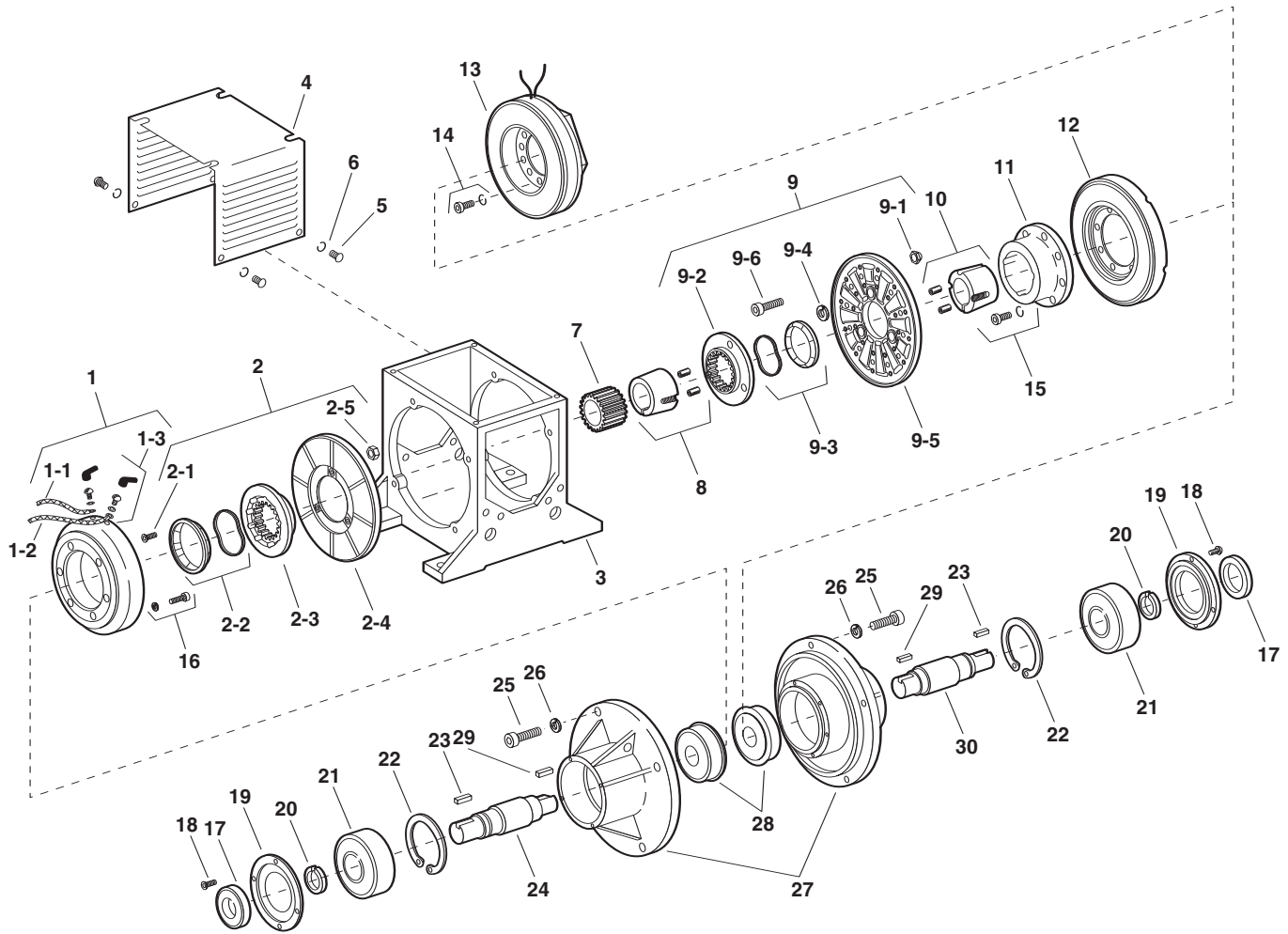

Component Parts

Item	Description	Part No.	Qty.
1	Magnet Assembly		1
	6 volt	5312-631-004	
	24 volt	5312-631-005	
	90 volt	5312-631-006	
1-1	Wire Assembly	5232-954-003	1
1-2	Wire Assembly	5232-954-004	1
1-3	Terminal Accessory	5311-101-001	1
2	Armature & Splined Adapter	5322-111-002	1
2-1	Button Head Screw	797-0272	1
2-2	Autocap Accessory	5322-101-004	1
2-3	Splined Arm, Adapter	104-0009	1
2-4	Armature	5322-111-036	1
2-5	Locknut	661-0004	3
3	Frame	174-0043	1
4	Dust Cover	287-0052	1
5	Button Head Screw	797-1175	8
6	Lockwasher	950-0103	8
7	Splined Armature Hub	540-0061	1
8	Bushing, 1-7/8" Bore	180-0177	1
9	Armature & Splined Adapter	5202-111-001	1
9-1	Locknut	661-0004	3
9-2	Splined Armature Adapter	104-0009	1
9-3	Autogap Accessory	5322-101-004	1
9-4	Spacer	748-0333	3
9-5	Armature	5322-111-036	1

Item	Description	Part No.	Qty.
9-6	Cap Screw	797-0341	3
10	Bushing, 2" Bore	180-0179	1
11	Rotor Hub	540-0315	1
12	Rotor	5202-751-003	1
13	Field Assembly		1
	6 volt	5202-451-004	
	24 volt	5202-451-006	
	90 volt	5202-451-007	
14	Mounting Accessory	5321-101-001	1
15	Mounting Accessory	5201-101-007	1
16	Mounting Accessory	5321-101-001	1
17	Oil Seal	795-0024	2
18	Button Head Screw	797-1008	8
19	Retainer Plate	686-0047	2
20	Retainer Ring – External	748-0504	2
21	Ball Bearing	166-0130	2
22	Retainer Ring – Internal	748-0375	2
23	Key	590-0024	2
24	Shaft, Brake	798-0026	1
25	Cap Screw	797-0361	8
26	Lockwasher	950-0362	8
27	Bearing Housing	535-0012	2
28	Ball Bearing	166-0131	2
29	Key	590-0025	2
30	Shaft, Clutch	798-0025	1

Refer to Service Manual P-212.

These units meet the standards of UL508 and are listed under guide card #NMTR, file #59164. These units are CSA certified under file #LR11543.

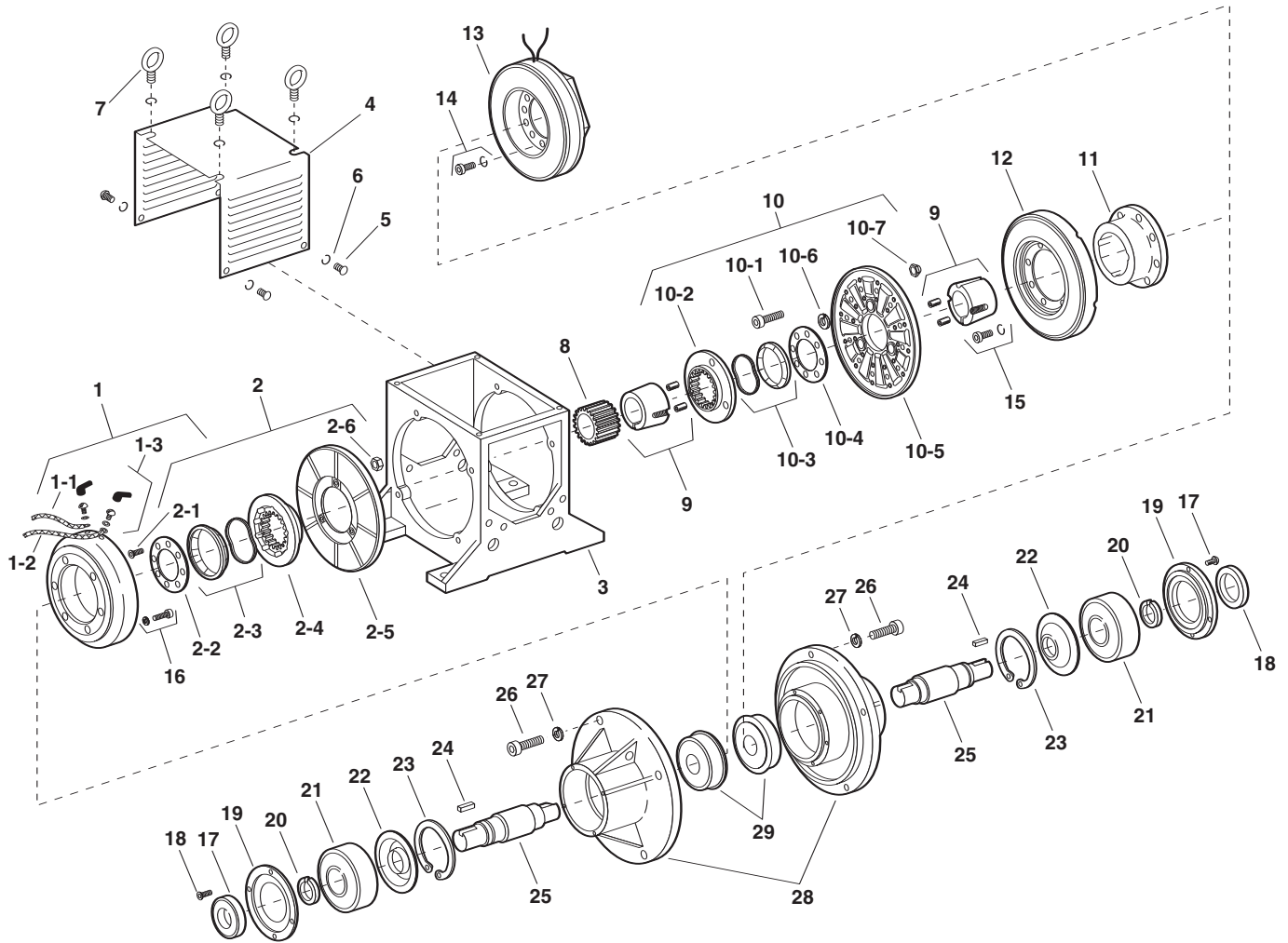

Component Parts

Item	Description	EP-1525		EP-1525HT	
		Part No.	Qty.	Part No.	Qty.
1	Magnet		1		1
	6 volt	5314-631-004			
	24 volt 90 volt	5314-631-005		5314-631-006 5314-631-005	
*1-1	Wire Assembly	5232-954-003	1	5232-954-003	1
*1-2	Wire Assembly	5232-954-004	1	5232-954-004	1
*1-3	Terminal Accessory	5311-101-001	1	5311-101-001	1
2	Armature & Splined Adapter	5324-111-001	1	5324-111-001	1
*2-1	Button Head Screw	797-0272	8	797-0272	8
*2-2	Armature Plate	686-0003	1	686-0003	1
*2-3	Autogap Accessory	5323-101-002	1	5323-101-002	1
*2-4	Splined Armature Adapter	104-0011	1	104-0011	1
*2-5	Armature	5324-111-034	1	5324-111-034	1
*2-6	Locknut	661-0004	8	661-0004	8
3	Frame	174-0044	1	174-0044	1
4	Dust Cover	287-0040	1	287-1002	1
5	Button Head Screw	797-1175	8	797-1175	8
6	Lock Washer	950-0103	8	950-0103	8
7	Eye Bolts	171-0006	4	171-0006	4
8	Splined Armature Hub	540-0063	1	540-0063	1
9	Bushing, 2-3/8" Bore	180-0215	2	180-0215	2
10	Armature & Splined Adapter	5204-111-004	1	5204-111-004	1
*10-1	Cap Screw	797-0342	8	797-0342	8
*10-2	Splined Armature Adapter	104-0011	1	104-0011	1
*10-3	Autogap Accessory	5323-101-002	1	5323-101-002	1
*10-4	Retainer Plate	686-0003	1	686-0003	1
*10-5	Armature	5324-111-034	1	5324-111-034	1
*10-6	Spacer	748-0333	8	748-0333	8
*10-7	Locknut	661-0004	8	661-0004	8
11	Rotor Hub	5234-541-001	1	5234-541-001	1
12	Rotor	5204-751-002	1	5204-751-001	1
13	Field Assembly		1		1
	6 volt	5204-451-013			
	24 volt 90 volt	5204-451-016		5204-451-066 5204-451-006	
14	Mounting Accessory	5321-101-002	2	5321-101-002	2
15	Mounting Accessory	5321-101-001	2	5321-101-001	2
16	Mounting Accessory	5321-101-001	2	5321-101-001	2
17	Screw	797-0294	8	797-0294	8
18	Oil Seal	795-0025	2	795-0025	2
19	Retainer Plate	686-0048	2	686-0048	2
20	Retaining Ring – External	748-0503	2	748-0503	2
21	Ball Bearing	166-0132	2	166-0132	2
22	Bearing Seal	795-0036	2	795-0036	2
23	Retainer Ring – Internal	748-0552	2	748-0052	2
24	Key	590-0028	2	590-0028	2
25	Shaft	798-0027	2	798-0027	2
26	Cap Screw	797-0362	12	797-0362	12
27	Lock Washer	950-0362	12	950-0362	12
28	Bearing Housing	535-0013	2	535-0013	2
29	Ball Bearing	166-0133	2	166-0133	2

* Shipped Assembled

Refer to Service Manual P-212.

These units meet the standards of UL508 and are listed under guide card #NMTR, file #59164. These units are CSA certified under file #LR11543.

Service Parts