

Warner Electric designed product uses electromagnetism to engage the clutches and brakes. When electric current is passed through a wire, lines of magnetic flux are created. Warner Electric uses coils of wire embedded into a C-shaped iron "shell". When the electrical current is passed through the coil the shell is magnetized with the magnetism concentrating at the ends of the shell. These are also called "poles". When a steel or iron plate is close to the poles it is attracted to them, and the two pieces clamp together. To accomplish stable operation, DC power is required for electric clutches and brakes.

In a PC type clutch or a brake, a cross section will appear like Figure 1. When DC power is applied a magnetic field causes the armature to clamp against the magnet. Since magnetism is the engaging force, it is appropriate in Warner Electric designs for the metal poles of the magnet to engage directly against the metal plate of the armature. Friction material is included in industrial clutches and brakes to provide longer life, greater heat dissipation and to reduce noise during engagement.

SF style clutches (Figure 2) have a stationary field and rotor in place of the magnet. They function in a similar manner. When current is applied to the field coil, magnetism is created. The magnetism travels to the rotor face where it engages the armature.

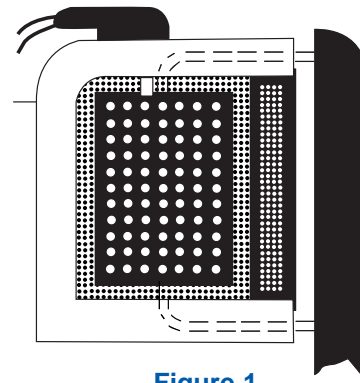

Figure 1

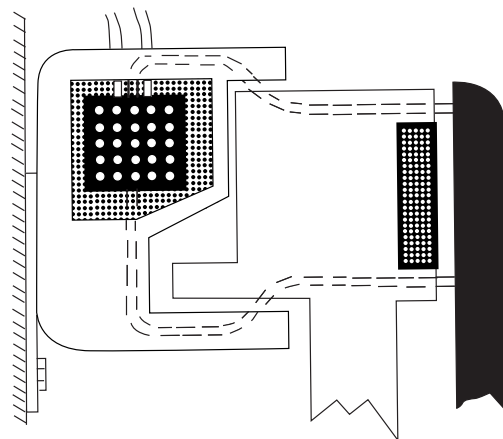

Figure 2

Dynamic Torque

NOTES:

Speed difference means the difference in speed between one friction face and the other at the moment of engagement.

The intersection of the top curve and the speed difference is the maximum torque produced by the unit. When both friction faces are engaged and rotating at the same speed, the unit is said to be locked-in and produces the maximum static torque (zero speed difference).

The % lines indicate the percentage of full voltage being used. Example: If 90 volt unit runs at 45 volts, use the 50% line.

Average Torque = Dynamic Torque at 1/2 operating speed. Example: If operating speed is 1800, use dynamic torque at 900.

Size 120 Maximum Speed 10,000 rpm
Static Torque 5 lb./in.

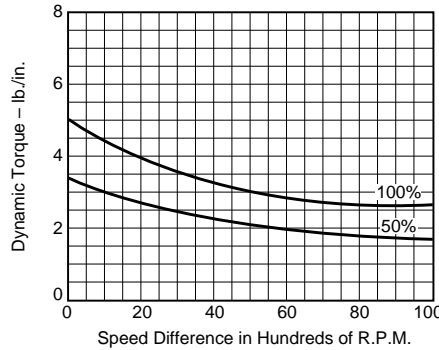

Size 170 Maximum Speed 10,000 rpm
Static Torque 15 lb./in.

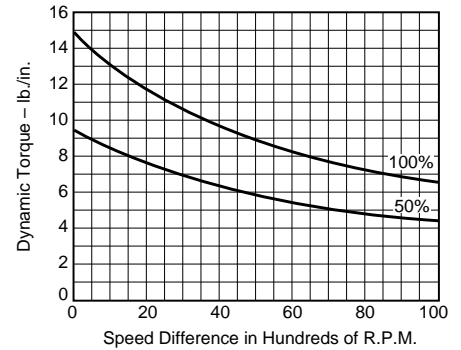

Size 250 Maximum Speed 7,500 rpm
Static Torque 70 lb./in.

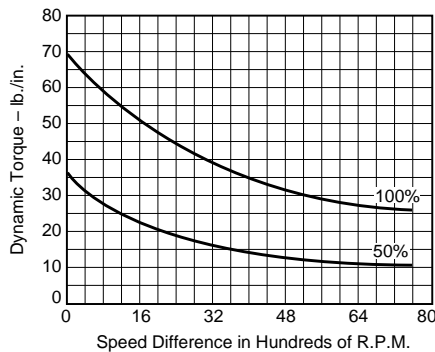

Size 400 Maximum Speed 4,500 rpm
Static Torque 270 lb./in.

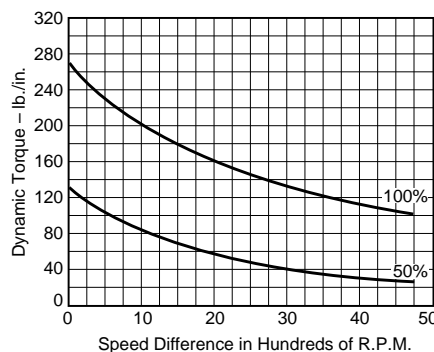

Size 500-SF Maximum Speed 4,000 rpm
Static Torque 50 lb./ft.

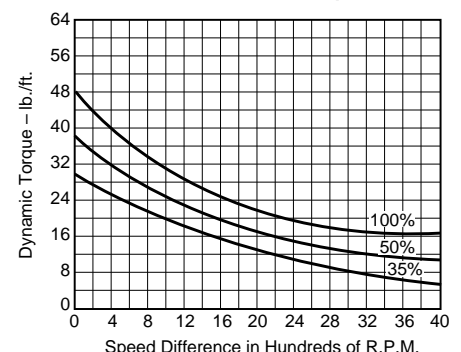

Size 500-PC/PB Maximum Speed 5,400 rpm
Static Torque 40 lb./ft.

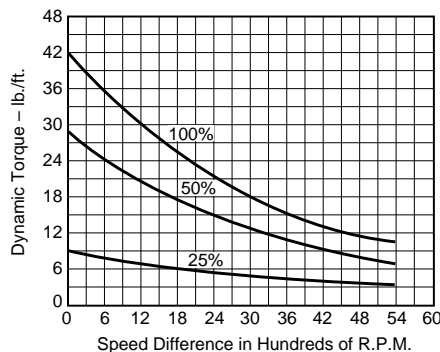

Size 650 Maximum Speed 3,600 rpm
Static Torque 95 lb./ft.

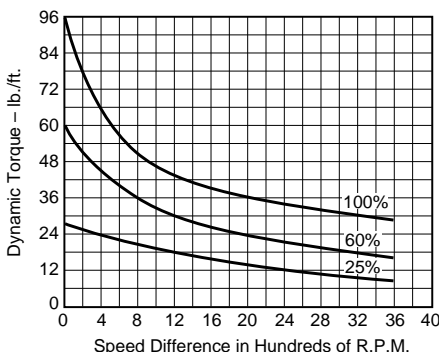

Size 825-SF Brg. Mtd. Maximum Speed 3,600 rpm
Static Torque 150 lb./ft.

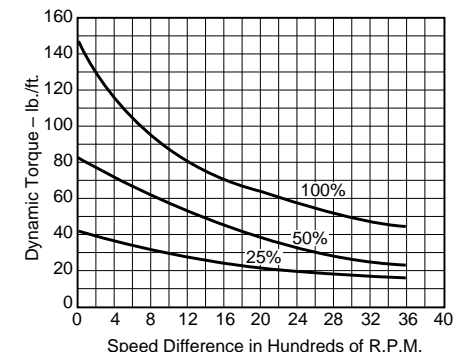

NOTE: Torque values are in inch lbs. for size 400 and smaller, and in ft.lbs. for size 500 and larger.

Dynamic Torque

Size 825 Maximum Speed 4,000 rpm
Electro-Pack 3,600 rpm
Static Torque 125 lb./ft.

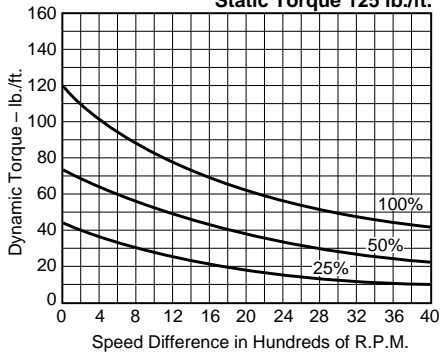

Size 825-MB Maximum Speed 4,000 rpm
Static Torque 80 lb./ft.

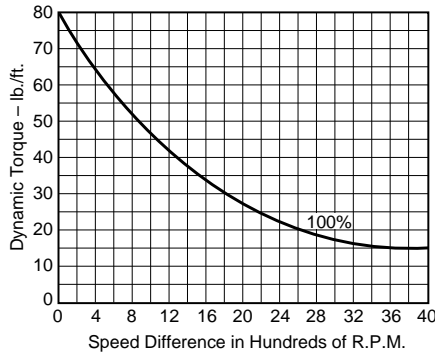

Size 1000 Maximum Speed 3,600 rpm
Electro-Pack 3,000 rpm
Static Torque 240 lb./ft.

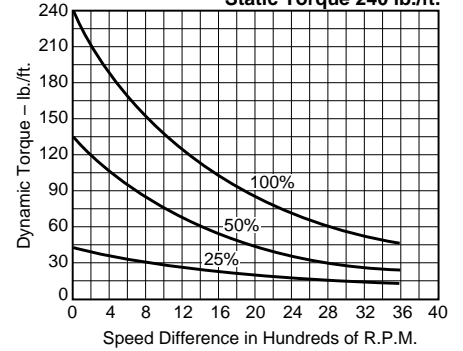

Size 1000-MB Maximum Speed 3,600 rpm
Static Torque 160 lb./ft.

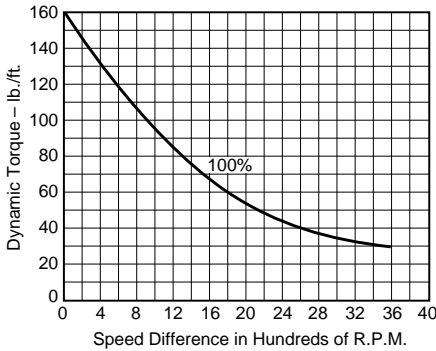

Size 1225 Maximum Speed 3,000 rpm
Static Torque 465 lb./ft.

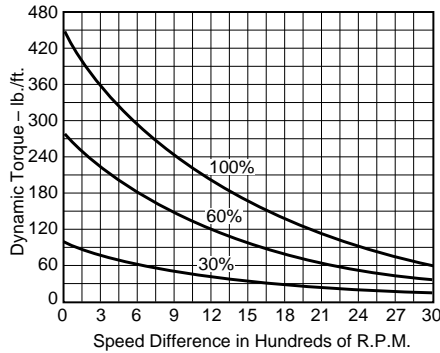

Size 1225-MB Maximum Speed 3,000 rpm
Static Torque 260 lb./ft.

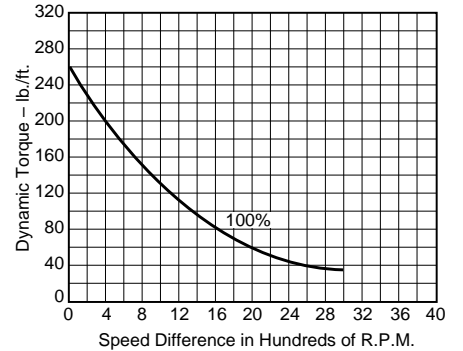

Size 1525 Maximum Speed 2,000 rpm
Electro-Pack 1,800 rpm
Static Torque 700 lb./ft.

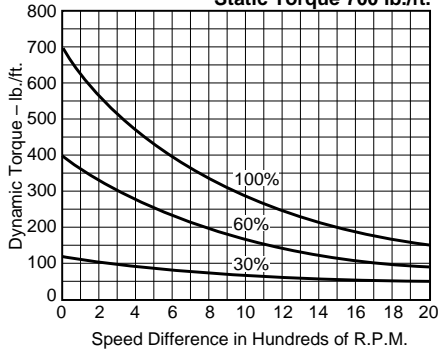

Size 1525-Hi Torque Maximum Speed 2,000 rpm
Static Torque 1,350 lb./ft.

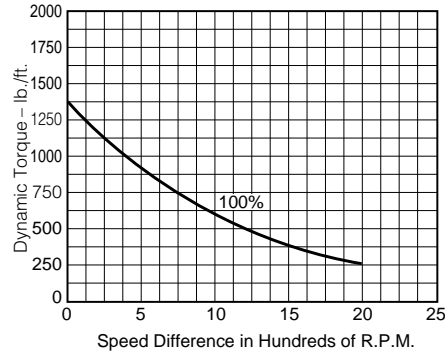

Heat Dissipation

To accelerate any part of a machine from rest to a given velocity or decelerate from a given velocity to rest, energy must be given to or taken from the part. This energy, neglecting friction and windage losses, is equal to the energy possessed by the part when moving at the given velocity.

Kinetic energy in parts that rotate about an axis such as gears, pulleys, and rotors is:

$$E = 1.7 \times WR^2 \times \left(\frac{N}{100}\right)^2$$

Where:

N = RPM

E = Energy, ft.lb.

WR² = Inertia, lb.ft.²

On repetitive cycles, the energy per minute may be determined by multiplying the energy calculation by the cycle frequency F:

$$a. E/min. = 1.7 \times WR^2 \times \left(\frac{N}{100}\right)^2 \times F$$

Where:

E/min. = Energy, ft.lb./min.

This becomes important when determining whether a given size clutch or brake is capable of dissipating the heat (energy) required to cycle a given load. To determine this, the heat dissipating capability of the clutch-brake must be calculated using the formula:

$$b. E/min. = \text{avg.}$$

$$\frac{t^1}{t^1 + t^2} \left(\frac{E/min.}{@RPM_1}\right) + \frac{t^2}{t^1 + t^2} \left(\frac{E/min.}{@RPM_2}\right)$$

Where:

t¹ = time(seconds) @ RPM₁

t² = time (seconds) @ RPM₂

RPM₁ = starting speed

RPM₂ = maximum speed

E/min. = energy rate from heat dissipation curves

The heat (energy) to be dissipated (per formula a. above) is then compared with the heat (energy) dissipating capacity (per formula b. above) of the clutch-brake to determine whether unit sizing is correct.

Example: A load of 5.353 lb.ft.² (includes couplings, bearings, etc.) is driven by a 15 HP, 700 RPM motor. Using an SF-1225 (bearing mounted, normal duty with armature in input side) and PB-1225 (normal duty, pin drive), determine whether this clutch-brake can be cycled 40 times per minute with an "on" time of one second without overheating.

1. Determine amount of heat which is dissipated at this cycle rate.

$$E = 1.7 \times WR^2 \times \left(\frac{N}{100}\right)^2 \times F$$

Total WR²: 5.353 lb.ft.² (load inertia)
 2.751 lb.ft.² (clutch inertia, ref. p. 239)
 2.147 lb.ft.² (brake inertia, ref. p. 239)
 Total = 10.251 lb.ft.²

$$E = 1.7 \times 10.251 \times \left(\frac{700}{100}\right)^2 \times 40$$

$$E = 34,156 \text{ ft.lbs./min.}$$

2. Determine the heat dissipating capacity of this clutch-brake combination.

E/min. = avg.

$$\frac{t^1}{t^1 + t^2} \left(\frac{E/min.}{@RPM_1}\right) + \frac{t^2}{t^1 + t^2} \left(\frac{E/min.}{@RPM_2}\right)$$

Where:

t¹ = .5 second

t² = 1 second

RPM₁ = 0

RPM₂ = 700

E/min. @ RPM₁ = 20,000 ft. lbs./min.

E/min @ RPM₂ = 47,000 ft.lbs./min.

$$E/min. \text{ avg.} = \frac{.5}{1.5} \times 20,000 + \frac{1}{1.5} \times 47,000$$

E/min. = 38,000 ft.lbs.

avg.

Since the capacity (38,000 ft. lbs./min.) is greater than the heat to be dissipated (34,156 ft. lbs./min.), this clutch-brake can be operated continuously at 40 cycles/ min. under the stated load without overheating.

Examples

Size 1225 Maximum Speed 3,000 rpm

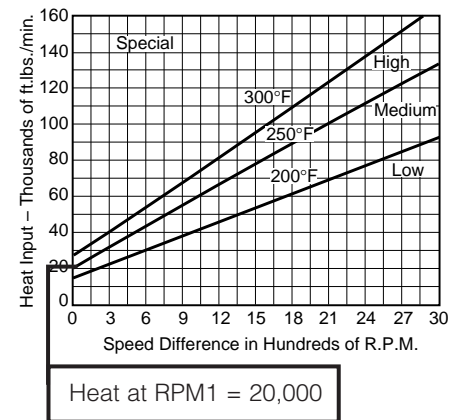

Size 1225 Maximum Speed 3,000 rpm

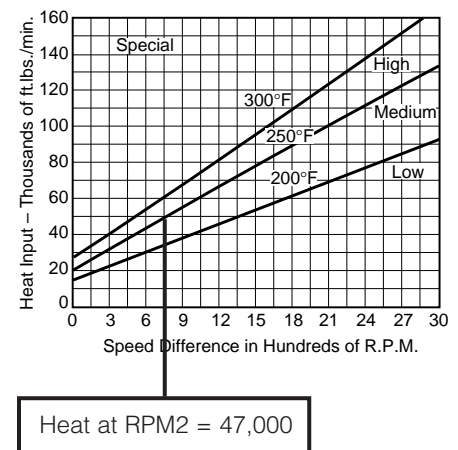

Note:

Select a clutch or brake with heat dissipation requirements below the 250° line. For heat greater than 250° but less than 300°, special coils are required.

Heat Dissipation

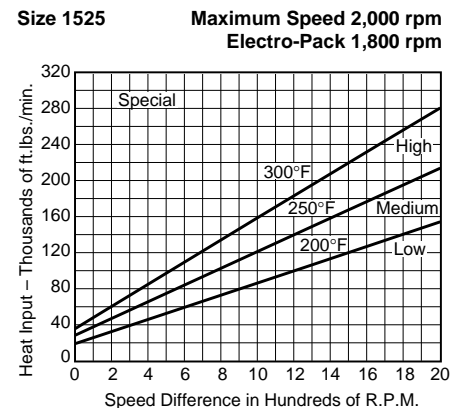
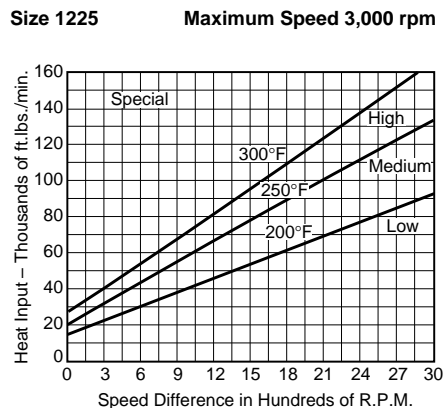
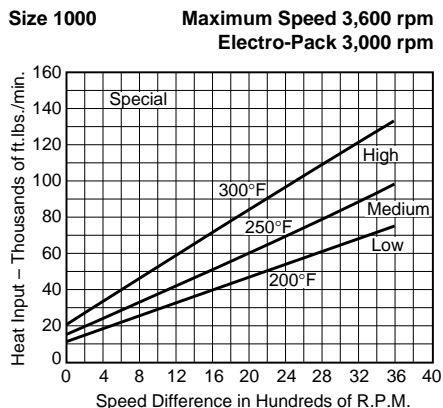
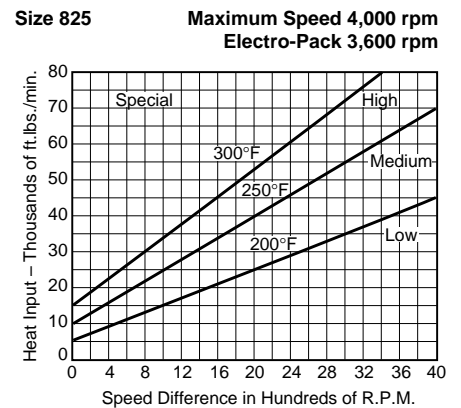
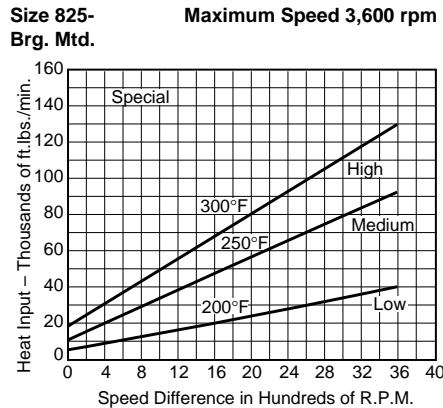
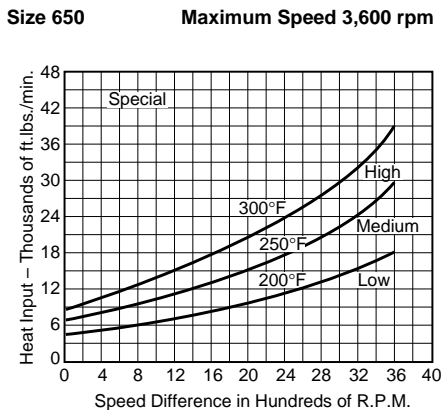
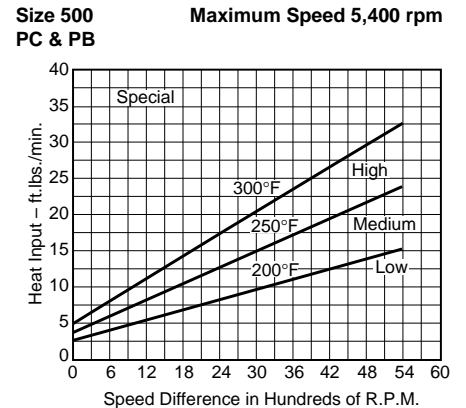
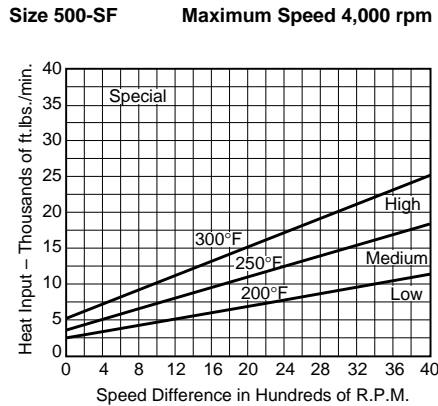
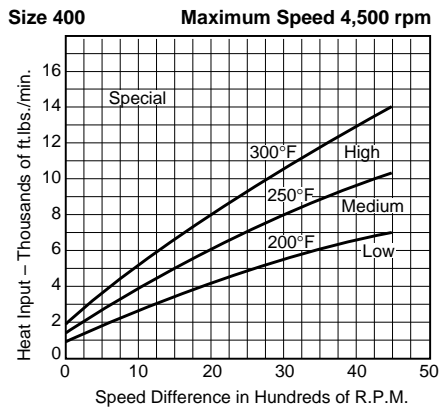
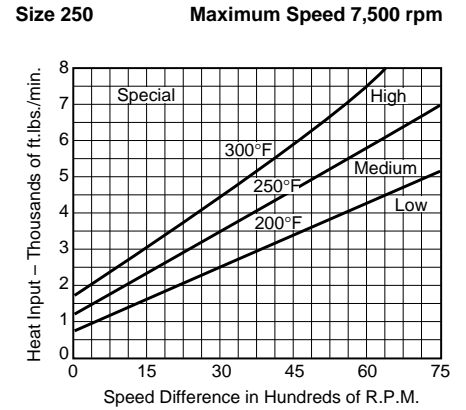
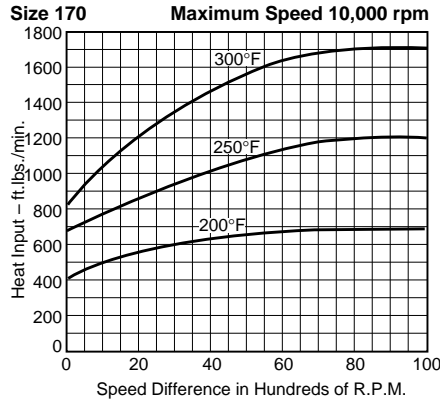
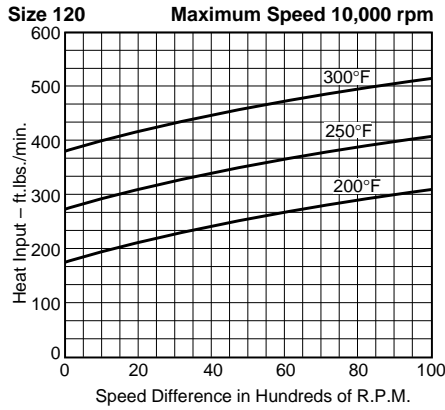

Moment of Inertia

Radii of Gyration for Rotating Bodies

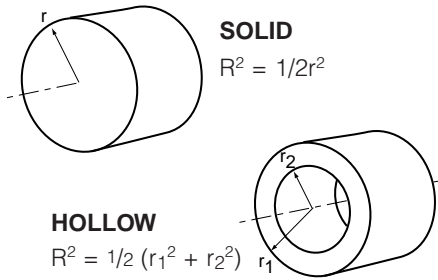

To simplify the calculation of the WR^2 of more complex parts, these drawings show shapes most commonly encountered and the formula for calculating radius of gyration squared (R^2). This multiplied by the weight of the part will give WR^2 .

When calculating radius of gyration (R^2) using the formula, be sure that all dimensions are converted to feet in order to get radius of gyration expressed in terms of pounds feet squared.

Inertia of Steel Shafting

Per Inch of Length or Thickness

To determine WR^2 of a given shaft or disc, multiply the WR^2 given above by the length of shaft, or thickness of disc, in inches.

NOTE: For hollow shafts, subtract WR^2 of the I.D. from the WR^2 of the O.D. and multiply by length.

Per Inch of Length or Thickness

Dia. (In.)	WR^2 (lb.ft. ²)	Dia. (In.)	WR^2 (lb.ft. ²)	Dia. (In.)	WR^2 (lb.ft. ²)
3/4	.00006	10-1/2	2.35	32	201.8
1	.0002	10-3/4	2.58	33	228.2
1-1/4	.0005	11	2.83	34	257.2
1-1/2	.001	11-1/4	3.09	35	288.8
1-3/4	.002	11-1/2	3.38	36	323.2
2	.003	11-3/4	3.68	37	360.7
2-1/4	.005	12	4.00	38	401.3
2-1/2	.008	12-1/4	4.35	39	445.3
2-3/4	.011	12-1/2	4.72	40	492.8
3	.016	12-3/4	5.11	41	543.9
3-1/2	0.029	13	5.58	42	598.8
3-3/4	0.038	13-1/4	5.96	43	658.1
4	0.049	13-1/2	6.42	44	721.4
4-1/4	0.063	13-3/4	6.91	45	789.3
4-1/2	0.079	14	7.42	46	861.8
5	0.120	14-1/4	7.97	47	939.3
5-1/2	0.177	14-1/2	8.54	48	1021.8
6	0.250	14-3/4	9.15	49	1109.6
6-1/4	0.296	15	9.75	50	1203.1
6-1/2	0.345	16	12.61	51	1302.2
6-3/4	0.402	17	16.07	52	1407.4
7	0.464	18	20.21	53	1518.8
7-1/4	0.535	19	25.08	54	1636.7
7-1/2	0.611	20	30.79	55	1761.4
7-3/4	0.699	21	37.43	56	1893.1
8	0.791	22	45.09	57	2031.9
8-1/4	0.895	23	53.87	58	2178.3
8-1/2	1.00	24	63.86	59	2332.5
8-3/4	1.13	25	75.19	60	2494.7
9	1.27	26	87.96	66	3652.5
9-1/4	1.41	27	102.30	72	5172
9-1/2	1.55	28	118.31	78	7125
9-3/4	1.75	29	136.14	84	9584
10	1.93	30	155.92	90	12629
10-1/4	2.13	31	177.77	96	16349
				102	20836

NOTE: The "Weight" column gives the "average" weight per item
The "Inertia" column gives the inertia of "rotating" components.

SF Series (Stationary Field Clutches)

Unit Size	SF-120, B.M.		SF-170, B.M.		SF-250, B.M.		SF-400, B.M.	
	Wt. (lbs.)	Inertia (lbs.in. ²)	Wt. (lbs.)	Inertia (lbs.in. ²)	Wt. (lbs.)	Inertia (lbs.in. ²)	Wt. (lbs.)	Inertia (lbs.in. ²)
Field & Rotor Assembly113	.00831	.356	.036	1.00	.253	3.59	2.157
Field.....	.053218651	2.13
Rotor049	.00717	.138	.036	.348	.253	1.459	2.157
Set Collar.....	.011	.00114029	.004
Armature018	.00378	.031	.014	.234	.255	.670	1.56
Armature Hub.....	.020	.00413	.071	.00518	.557	.202	.540	.213
Antibacklash Armature.....00467025293	1.751
Unit Size	SF-120, F.M.		SF-170, F.M.		SF-250, F.M.		SF-400, F.M.	
	Wt. (lbs.)	Inertia (lbs.in. ²)	Wt. (lbs.)	Inertia (lbs.in. ²)	Wt. (lbs.)	Inertia (lbs.in. ²)	Wt. (lbs.)	Inertia (lbs.in. ²)
Field060250678	2.433
Rotor.....	.049	.00717	.127	.033	.367	.267	1.386	2.152
Armature018	.00378	.031	.014	.234	.255	.670	1.56
Armature Hub.....	.020	.00413	.071	.00518	.111	.030	.540	.213
Antibacklash Armature.....00467025293	1.751
Unit Size	SF-500, B.M.		SF-650, B.M.		SF-650, F.M.		SF-650, F.M.	
	Wt. (lbs.)	Inertia (lbs.ft. ²)	Wt. (lbs.)	Inertia (lbs.ft. ²)	Wt. (lbs.)	Inertia (lbs.ft. ²)	Wt. (lbs.)	Inertia (lbs.ft. ²)
Field & Rotor Assembly			5.947	.036	9.8	.21
Field.....			3.618	4.4	4.4
Rotor			2.329	.036	2.3	.20	2.3	.20
Rotor Hub.....			1.8	.01	1.8	.01
Armature & Pins			1.20	.033	1.8	.08	1.8	.08
Unit Size	SF-825, F.M.		SF-1000, F.M.		SF-825, F.M.		SF-1000, F.M.	
	Wt. (lbs.)	Inertia (lbs.ft. ²)	Wt. (lbs.)	Inertia (lbs.ft. ²)	Wt. (lbs.)	Inertia (lbs.ft. ²)	Wt. (lbs.)	Inertia (lbs.ft. ²)
Field & Rotor Assembly					8.750	11.125
Field.....					5.148	.381	7.880	.894
Rotor311	.003	1.089	.027
Rotor Hub.....					4.783	.323	6.0	.624
Armature & Pins315	.0015	.810	.088
Bushing: Max. Bore to583	.0018	1.685	.011
Min. Bore								
Unit Size	SF-825, B.M.		SF-1000, B.M.		SF-1225, B.M.		SF-1525, B.M.	
	Wt. (lbs.)	Inertia (lbs.ft. ²)	Wt. (lbs.)	Inertia (lbs.ft. ²)	Wt. (lbs.)	Inertia (lbs.ft. ²)	Wt. (lbs.)	Inertia (lbs.ft. ²)
Field & Rotor Assembly	15.552	.756	26.905	1.004	49.455	2.75	73.316	5.989
Field.....	8.994	11.125	21.250	30.750
Field Hub & Brg.	3.400	5.800	12.200
Rotor	6.558	.756	7.880	.894	14.005	2.421	18.266	5.139
Rotor Hub	4.500	.110	8.400	.330	12.100	.850
Armature & Pins	4.738	.373	6.0	.624	10.84	1.7	15.362	3.962
Bushing: Max. Bore to301	.002	.810	.008	1.553	.022	3.234	.071
Min. Bore762	.003	1.685	.011	3.575	0.31	6.345	.099
Unit Size	SF-1225, F.M.		SF-1525, F.M.		SF-1525, F.M.		SF-1525, H.T.	
	Wt. (lbs.)	Inertia (lbs.ft. ²)	Wt. (lbs.)	Inertia (lbs.ft. ²)	Wt. (lbs.)	Inertia (lbs.ft. ²)	Wt. (lbs.)	Inertia (lbs.ft. ²)
Field			21.250	30.750	29.500
Rotor.....			14.005	2.421	18.266	5.139	20.493	5.866
Rotor Hub.....			2.181	.081	4.963	.323	4.963	.323
Bushing: Max. Bore to			1.553	.022	3.234	.071	3.234	.071
Unit Size			3.575	.031	6.345	.099	6.345	.099
Armature & Splined Adapter	22.528	4.498
Armature & Pins			10.84	1.7	15.362	3.962
Splined Hub	2.792	.069

Weights and Inertia

SFC Series (Stationary Field Clutch Couplings)

NOTE: The "Weight" column gives the "average" weight per item. The "Inertia" column gives the inertia of "rotating" components.

Unit Size	SFC-120, B.M.		SFC-170, B.M.		SFC-250, B.M.		SFC-400, B.M.			
	Wt. (lbs.)	Inertia (lbs.in. ²)	Wt. (lbs.)	Inertia (lbs.in. ²)	Wt. (lbs.)	Inertia (lbs.in. ²)	Wt. (lbs.)	Inertia (lbs.in. ²)		
Field & Rotor Assembly113	.00831	.356	.036	1.00	.253	3.59	2.157		
Field.....	.053218651	2.13		
Rotor.....	.049	.00717	.138	.036	.348	.253	1.459	2.157		
Set Collar.....	.011	.00114029	.004		
Armature018	.00378	.031	.014	.234	.255	.670	1.56		
Armature Hub.....	.019	.000407	.032	.00223	.111	.030	.249	.091		
Antibacklash Armature.....00456024293	1.751		
Unit Size	SFC-120, F.M.		SFC-170, F.M.		SFC-250, F.M.		SFC-400, F.M.			
	Wt. (lbs.)	Inertia (lbs.in. ²)	Wt. (lbs.)	Inertia (lbs.in. ²)	Wt. (lbs.)	Inertia (lbs.in. ²)	Wt. (lbs.)	Inertia (lbs.in. ²)		
Field060250678	2.433		
Rotor.....	.049	.00717	.127	.033	.367	.267	1.386	2.152		
Armature018	.00378	.031	.014	.234	.255	.670	1.56		
Armature Hub.....	.019	.000407	.032	.00223	.111	.030	.249	.091		
Antibacklash Armature.....00456024293	1.751		
Unit Size					SFC-500, N.D.		SFC-500, H.D.			
					Wt. (lbs.)	Inertia (lbs.ft. ²)	Wt. (lbs.)	Inertia (lbs.ft. ²)		
Field & Rotor Assembly					5.947	.036	5.947	.036		
Field.....					3.618	3.618		
Rotor					2.329	.036	2.329	.036		
Armature & Pins					1.20	.033		
Armature	1.192	.029		
Armature Hub.....					.941	.018	.161	.0007		
Bushing: Max. Bore to436	.002		
Min. Bore842	.003		
Unit Size					SFC-650, B.M.		SFC-650, F.M.			
					Wt. (lbs.)	Inertia (lbs.ft. ²)	Wt. (lbs.)	Inertia (lbs.ft. ²)		
Field & Rotor Assembly					9.8	.21		
Field.....					4.4	4.4		
Rotor					2.3	.20	2.3	.20		
Rotor Hub.....					1.8	.01	1.8	.01		
Armature & Pins					1.8	.08	1.8	.08		
Armature Hub.....					1.3	.02	1.3	.02		
Unit Size	SFC-825, B.M.		SFC-1000, B.M.		SFC-1225, B.M.		SFC-1525, B.M.			
	Wt. (lbs.)	Inertia (lbs.ft. ²)	Wt. (lbs.)	Inertia (lbs.ft. ²)	Wt. (lbs.)	Inertia (lbs.ft. ²)	Wt. (lbs.)	Inertia (lbs.ft. ²)		
Field & Rotor Assembly	15.552	.756	26.905	1.004	49.455	2.75	73.316	5.989		
Field.....	8.994	11.125	21.250	30.750		
Field Hub & Brg.	3.400	5.800	12.200		
Rotor	6.558	.756	7.880	.894	14.005	2.421	18.266	5.139		
Rotor Hub	4.500	.110	8.400	.330	12.100	.850		
Bushing - Rotor Hub: Max. Bore to600	.004	.810	.008	1.533	.022	3.234	.071		
Min. Bore.....	1.276	.005	1.685	.010	3.575	0.31	6.345	.099		
Armature & Splined Adapter	5.263	.326	6.84	.667	13.408	1.817	22.528	4.498		
Splined Hub834	.006	3.547	.077	3.582	.077	3.582	.077		
Bushing - Splined Hub: Max. Bore to301	.0026	2.064	.033	2.064	.033	2.064	.033		
Min. Bore762	.0039	4.171	.048	4.171	.048	4.171	.048		
Unit Size	SFC-825, F.M.		SFC-1000, F.M.		SFC-1225, F.M.		SFC-1525, F.M.		SFC-1525, H.T.	
	Wt. (lbs.)	Inertia (lbs.ft. ²)	Wt. (lbs.)	Inertia (lbs.ft. ²)	Wt. (lbs.)	Inertia (lbs.ft. ²)	Wt. (lbs.)	Inertia (lbs.ft. ²)	Wt. (lbs.)	Inertia (lbs.ft. ²)
Field.....	8.750	11.125	21.250	30.750	29.500
Rotor	5.148	.381	7.880	.894	14.005	2.421	18.266	5.139	20.493	5.866
Rotor Hub311	.003	1.089	.027	2.181	.081	4.963	.323	4.963	.323
Bushing-Rotor Hub: Max. Bore to315	.0015	.810	.008	1.553	.022	3.234	.071	3.234	.071
Min. Bore583	.0018	1.685	.011	3.575	.031	6.345	.099	6.345	.099
Armature & Splined Adapter.....	5.263	.326	6.84	.667	13.408	1.817	22.528	4.498	22.528	4.498
Splined Hub834	.006	3.547	.077	3.582	.077	3.582	.077	3.582	.077
Bushing-Splined Hub: Max. Bore to ..	.301	.0026	2.064	.033	2.064	.033	2.064	.033	2.064	.033
Min. Bore762	.0039	4.171	.048	4.171	.048	4.171	.048	4.171	.048

Weights and Inertia

NOTE: The "Weight" column gives the "average" weight per item.
The "Inertia" column gives the inertia of "rotating" components.

PC Series (Primary Clutches)

Unit Size	PC-500							
	Wt. (lbs.)		Inertia (lbs.ft. ²)		Wt. (lbs.)		Inertia (lbs.ft. ²)	
Magnet	2.800		.074		2.800		.074	
Magnet Hub Assembly	1.224		.031		1.224		.031	
Armature & Pins	1.20		.033		1.20		.033	
Armature	
Armature Hub.....	
Bushing: Max. Bore to	
Min. Bore.....	
Unit Size	PC-825		PC-1000		PC-1225		PC-1525	
	Wt. (lbs.)	Inertia (lbs.ft. ²)	Wt. (lbs.)	Inertia (lbs.ft. ²)	Wt. (lbs.)	Inertia (lbs.ft. ²)	Wt. (lbs.)	Inertia (lbs.ft. ²)
Magnet	7.178	.571	10.549	1.297	18.557	3.245	27.817	7.416
Magnet Hub Assembly	4.362	.257	5.702	.332	7.252	.461	9.350	.680
Armature & Pins	4.783	.323	6.0	.629	10.84	1.7	15.362	3.925
Bushing: Max. Bore to600	.004	1.553	.022	4.055	.085	4.055	.085
Min. Bore.....	1.276	.005	3.575	.031	9.141	.133	9.141	.133

PCC Series (Primary Clutch Couplings)

Unit Size	PCC-500, N.D.								PCC-500, H.D.			
	Wt. (lbs.)		Inertia (lbs.ft. ²)		Wt. (lbs.)		Inertia (lbs.ft. ²)		Wt. (lbs.)		Inertia (lbs.ft. ²)	
Magnet	2.800		.074		2.800		.074		2.800		.074	
Magnet Hub Assembly	1.224		.031		1.224		.031		1.224		.031	
Armature & Pins	1.20		.033		
Armature		1.192		.029		
Armature Hub.....	.941		.018		.161		.0007		
Bushing: Max. Bore to436		.002		
Min. Bore.....	.842		.003		
Unit Size	PCC-825		PCC-1000		PCC-1225		PCC-1525		PCC-825		PCC-1000	
	Wt. (lbs.)	Inertia (lbs.ft. ²)	Wt. (lbs.)	Inertia (lbs.ft. ²)	Wt. (lbs.)	Inertia (lbs.ft. ²)	Wt. (lbs.)	Inertia (lbs.ft. ²)	Wt. (lbs.)	Inertia (lbs.ft. ²)	Wt. (lbs.)	Inertia (lbs.ft. ²)
Magnet	7.780	.571	10.549	1.297	18.557	3.245	27.817	7.416	7.780	.571	10.549	1.297
Magnet Hub Assembly	4.362	.257	5.702	.332	7.252	.461	9.350	.680	4.362	.257	5.702	.332
Armature & Splined Adapter	5.263	.326	6.84	.667	13.408	1.817	22.528	4.498	5.263	.326	6.84	.667
Splined Hub834	.006	3.547	.077	3.582	.077	3.582	.077	.834	.006	3.547	.077
Bushing - Magnet Hub												
Max. Bore to600	.004	1.533	.022	4.055	.085	4.055	.085	.600	.004	1.533	.022
Min. Bore	1.276	.005	3.575	.031	9.141	.133	9.141	.133	1.276	.005	3.575	.031
Bushing - Splined Hub												
Max. Bore to301	.002	2.064	.033	2.064	.033	2.064	.033	.301	.002	2.064	.033
Min. Bore762	.003	4.171	.048	4.171	.048	4.171	.048	.762	.003	4.171	.048

Weights and Inertia

PB Series (Primary Brakes)

NOTE: The "Weight" column gives the "average" weight per item. The "Inertia" column gives the inertia of "rotating" components.

Unit Size	PB-120		PB-170		PB-250		PB-400	
	Wt. (lbs.)	Inertia (lbs.in. ²)	Wt. (lbs.)	Inertia (lbs.in. ²)	Wt. (lbs.)	Inertia (lbs.in. ²)	Wt. (lbs.)	Inertia (lbs.in. ²)
Magnet.....	.090263846	3.034
Armature018	.00378	.031	.014	.234	.255	.670	1.56
Armature Hub.....	.019	.000407	.032	.00223	.111	.030	.249	.091
Antibacklash Armature.....00456024293	1.751
Unit Size			PB-500, N.D.		PB-500, H.D.		PB-650	
	Wt. (lbs.)	Inertia (lbs.ft. ²)	Wt. (lbs.)	Inertia (lbs.ft. ²)	Wt. (lbs.)	Inertia (lbs.ft. ²)	Wt. (lbs.)	Inertia (lbs.ft. ²)
Magnet.....			2.800	2.800	4.5
Armature & Pins.....			1.20	.033				
Armature					1.192	.029	1.8	.08
Armature Hub.....			.941	.018	.161	.0007	1.3	.02
Bushing: Max. Bore to436	.002
Min. Bore.....			.842	.003
Unit Size	PB-825, N.D.		PB-1000, N.D.		PB-1225, N.D.		PB-1525, N.D.	
	Wt. (lbs.)	Inertia (lbs.ft. ²)	Wt. (lbs.)	Inertia (lbs.ft. ²)	Wt. (lbs.)	Inertia (lbs.ft. ²)	Wt. (lbs.)	Inertia (lbs.ft. ²)
Magnet.....	7.780	10.549	18.557	27.817
Armature	4.783	.323	6.0	.629	10.227	1.667	15.362	3.925
Armature Hub.....	1.857	.043	3.860	.164	6.716	.380	8.127	.602
Bushing: Max. Bore to600	.004	1.553	.022	4.055	.085	4.055	.085
Min. Bore.....	1.276	.005	3.575	.031	9.141	.133	9.141	.133
Unit Size	PB-825, H.D.		PB-1000, H.D.		PB-1225, H.D.		PB-1525, H.D.	
	Wt. (lbs.)	Inertia (lbs.ft. ²)	Wt. (lbs.)	Inertia (lbs.ft. ²)	Wt. (lbs.)	Inertia (lbs.ft. ²)	Wt. (lbs.)	Inertia (lbs.ft. ²)
Magnet.....	7.780	10.549	18.557	27.817
Armature & Splined Adapter	5.263	.326	6.84	.667	13.317	1.737	22.528	4.498
Splined Hub834	.006	3.547	.077	3.582	.077	3.582	.077
Bushing - Spline Hub								
Max. Bore to301	.002	2.064	.033	2.064	.033	2.064	.033
Min. Bore762	.003	4.171	.048	4.171	.048	4.171	.048

MB Series (Motor Brakes)

Unit Size	MB-825		MB-1000		MB-1225	
	Wt. (lbs.)	Inertia (lbs.ft. ²)	Wt. (lbs.)	Inertia (lbs.ft. ²)	Wt. (lbs.)	Inertia (lbs.ft. ²)
Magnet.....	7.780	10.549	18.557
Armature & Pins.....	4.783	.323	6.0	.629	10.84	1.7
Armature Hub.....	1.857	.043	3.860	.164	6.716	.380
Bushing: Max. Bore to600	.004	1.533	.022	1.553	.022
Min. Bore.....	1.276	.005	3.575	.031	3.575	.031
Cover	3.687	4.875	6.0
Adapter	3.5	5.5	7.0

PCB Series (Primary Clutch/Brake Comination)

Unit Size	PCB-825		PCB-1000		PCB-1225	
	Wt. (lbs.)	Inertia (lbs.ft. ²)	Wt. (lbs.)	Inertia (lbs.ft. ²)	Wt. (lbs.)	Inertia (lbs.ft. ²)
Magnet - Brake	7.780	10.549	18.557
Magnet - Clutch	7.780	.571	10.549	1.297	18.557	3.245
Magnet Hub Assembly	4.362	.257	5.702	.332	7.252	.461
Bushing: Max. Bore to600	.004	1.553	.022	4.055	.085
Min. Bore.....	1.276	.005	3.575	.031	9.141	.133
Armature & Pins.....	4.783	.323	6.0	.629	10.84	1.7
Unit Size			PCB-1225/1000		PCB-1525/1225	
	Wt. (lbs.)	Inertia (lbs.ft. ²)	Wt. (lbs.)	Inertia (lbs.ft. ²)	Wt. (lbs.)	Inertia (lbs.ft. ²)
Magnet - Brake			10.549	18.557
Magnet - Clutch			18.557	3.245	27.817	7.416
Magnet Hub Assembly			5.702	.332	9.350	.680
Bushing - Magnet Hub: Max. Bore to			1.553	.022	4.055	.085
Min. Bore.....			3.575	.031	9.141	.133
Armature & Pins - Brake			6.0	.629	10.227	1.667
Armature & Pins - Clutch			10.227	1.667	15.362	3.925

Weights and Inertia

NOTE: The "Weight" column gives the "average" weight per item
The "Inertia" column gives the inertia of "rotating" components.

SFPBC Series (Stationary Field Clutch/Brake Couplings)

Unit Size	SFPBC-500, N.D.		SFPBC-650, N.D.	
	Wt. (lbs.)	Inertia (lbs.ft. ²)	Wt. (lbs.)	Inertia (lbs.ft. ²)
Field & Rotor Assembly	5.947	.036	9.8	.21
Field.....	3.618	4.4
Rotor	2.329	.036	2.3	.20
Rotor Hub.....	1.8	.01
Magnet.....	2.800	4.5
Magnet Hub Assembly
Armature
Armature & Pins.....	1.20	.033	1.8	.08
Armature Hub.....	.941	.018	1.3	.02
Bushing: Max. Bore to436	.002
Min. Bore.....	.842	.003

PCBC Series (Primary Clutch/Brake Couplings)

Unit Size	PCBC-500, N.D.		PCBC-500, H.D.			
	Wt. (lbs.)	Inertia (lbs.ft. ²)	Wt. (lbs.)	Inertia (lbs.ft. ²)		
Field & Rotor Assembly		
Field.....		
Rotor		
Rotor Hub.....		
Magnet.....	2.800	.074	2.800	.074		
Magnet Hub Assembly	1.224	.031	1.224	.031		
Armature	1.192	.029		
Armature & Pins.....	1.20	.033		
Armature Hub.....	.941	.018		
Bushing: Max. Bore to941	.002	.436	.002		
Min. Bore.....	.842	.003	.842	.003		
Splined Hub: 5300-541-006.....	1.914	.0073		
5300-541-007.....	1.800	.0071		
5300-541-008.....	1.735	.0071		
5300-541-009.....	1.667	.0069		
5300-541-010.....	1.518	.0067		
5300-541-011.....	1.351	.0063		
Unit Size	PCBC-825		PCBC-1000		PCBC-1225	
	Wt. (lbs.)	Inertia (lbs.ft. ²)	Wt. (lbs.)	Inertia (lbs.ft. ²)	Wt. (lbs.)	Inertia (lbs.ft. ²)
Magnet - Brake	7.780	10.549	18.557
Magnet - Clutch	7.780	.571	10.549	1.297	18.557	3.495
Magnet Hub Assembly	4.362	.257	5.702	.332	7.252	.461
Bushing - Magnet Hub: Max. Bore to600	.004	1.553	.022	4.055	.085
Min. Bore	1.276	.005	3.575	.031	9.141	.133
Armature & Splined Adapter - Clutch	4.49	.281	6.942	.625	13.317	1.671
Armature & Pins - Brake	5.263	.326	6.84	.667	13.408	1.817
Splined Hub	4.783	.323	6.0	.629	10.84	1.7
Bushing - Splined Hub: Max. Bore to301	.002	2.064	.033	2.064	.033
Min. Bore762	.003	4.171	.048	4.171	.048
Unit Size	PCBC-1225/1000		PCBC-1525/1225			
	Wt. (lbs.)	Inertia (lbs.ft. ²)	Wt. (lbs.)	Inertia (lbs.ft. ²)		
Magnet - Brake	10.549	18.557		
Magnet - Clutch	18.557	3.495	27.817	7.416		
Magnet Hub Assembly	5.702	.332	9.350	.680		
Bushing - Magnet Hub: Max. Bore to	1.553	.022	4.055	.085		
Min. Bore	3.575	.031	9.141	.133		
Armature & Splined Adapter - Clutch	13.523	1.737	22.528	4.498		
Armature - Brake	6.0	.629	15.362	3.925		
Splined Hub	3.582	.077	3.582	.077		
Bushing - Splined Hub: Max. Bore to	2.064	.033	2.064	.033		
Min. Bore	4.171	.048	4.171	.048		

Rotational Speed

Rotational Speed

Rotational speed of a clutch or brake is an important consideration when selecting a unit for a particular application. Numerous factors must be considered, such as the maximum rated speed of the clutch/brake unit, the dynamic torque required, the heat dissipation needed, the effect of speed on wear rate, and torque stability at very low speeds. Each of these issues are separate, and sometimes interrelated, but always important in selecting the right product for an application.

Maximum RPM Rating

The most important rotational speed consideration is the maximum rated RPM capability of a unit. DO NOT exceed this rating. Exceeding the maximum RPM of a unit may cause personal injury and/or machine damage. Maximum rated speeds are based on the structural integrity of the rotating components and associated shaft and bearing capabilities. If the RPM rating is exceeded, structural failure may occur, or the unit may experience premature bearing failure and/or premature friction material wear out.

Dynamic Torque

When determining the correct size clutch/brake for an application, dynamic torque at the highest slip speed is often the determining factor. As you can see by reviewing the dynamic torque curves for different units as shown starting on page 234, dynamic clutch/brake torque usually decreases with higher speeds. As slip RPM increases, the coefficient of friction of a unit decreases, causing a decrease in dynamic torque availability. Be careful to consider this when selecting the appropriate unit size needed.

Warner Electric has devised a simple to use selection chart based on motor HP and unit RPM. See pages 8 and 9.

Heat Dissipation

Heat dissipation is inversely related to dynamic torque. As RPM increases, the heat dissipation ability of a unit increases. When an armature is rotating, the heat dissipation rate is proportional to the aerodynamic fan effect of the rotating armature. The faster the armature rotates, the greater the heat dissipation. This is illustrated with a typical catalog curve as shown in Figure 1. It's interesting to note that, at zero RPM, the unit still has some heat dissipation capability. This is due to convection and radiation, but is usually not an important consideration.

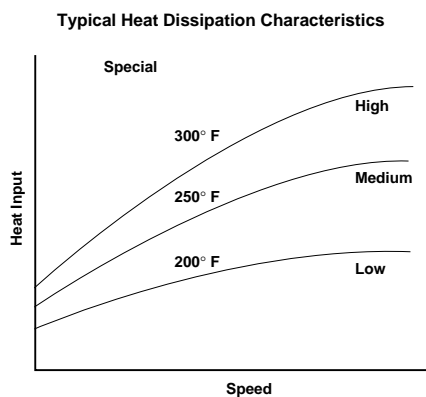

Figure 1

Wear Rate

The wear rate of friction surfaces is dependent on the clamping pressure of the mating surfaces as well as the surface velocity between the wearing surfaces. Many variables are involved in predicting wear life, of which RPM is probably the most influential. Typically, the wear rate will increase directly with the rubbing velocity distance. Another way of stating this is the higher the relative engagement speeds of two rotating parts, the longer they are allowed to slip against each other and the faster the wear rate.

Low Speed Operation

The effect of low speed usage should also be considered in applications. Performance of clutch/brake units at less than 100 RPM may be very different than at higher RPM. This is due to "burnish" characteristics of friction surfaces.

Wear In

"Burnish" is the wear in, or mating of two surfaces. When new, these surfaces have manufacturing features which include roughness and waviness. When these surfaces come into initial contact, only the high spots actually meet. See Figure 2. This results in only a small surface area in contact, while the non-contact surface area is "air." The result is low torque. As the mating surfaces continue to engage and slip against each other, the high spots are worn down and more surface area is in contact, thus increasing torque capability. This wear in period, or burnish, typically occurs in the first few hundred cycles of a clutch/brake's life. Faster slip speeds and higher loads mean fewer cycles needed to complete the burnish process. For applications where the speed is less than 100 RPM, the required application torque should be doubled to compensate for the low speed "burnish" that the unit

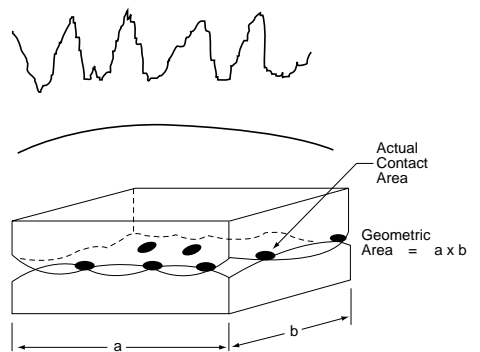

Figure 2 Unburnished Contact Areas

experiences. A low speed burnish will require many cycles before full torque and stability are achieved. For example, if an application is determined to need 20 ft.lbs. of static torque, an SF-400 clutch could be selected. But, if the application is only 100 RPM or less, then an SF-500 unit should be the choice to compensate for the low RPM usage, as indicated on the selection chart found on page 234.

Careful consideration of rotating speeds will help the selection process of an application. Follow these guidelines and the proper clutch/brake selected will provide troublefree operation.

Many Warner Electric clutch assemblies have a bearing mounted stationary field. By design the bearing maintains its proper position between the field and rotor making it easy for the customer to mount the field-rotor assembly. However, the bearing has a slight drag which tends to make the field rotate if not restrained. And, since the field has lead wires attached, it must be restrained to prevent rotation and pulling of these wires. To counteract this rotational force, the field has a "torque tab" to which the customer must attach an appropriate anti-rotational restraint.

A few hints regarding proper torque tab restraints are in order. First and foremost, it is important to recognize that the force to be overcome is very small and the tab should not be restrained in any manner which will preload the bearing. For example, if the clutch is mounted with the back of the field adjacent to a rigid machine member the customer should not attach a capscrew tightly between the tab and the machine member. This may pull the tab back against the rigid member as shown in Figure 1 and preload the bearing. The recommended methods are illustrated in Figures 2, 3, and 4. The method selected is primarily a matter of customer preference or convenience.

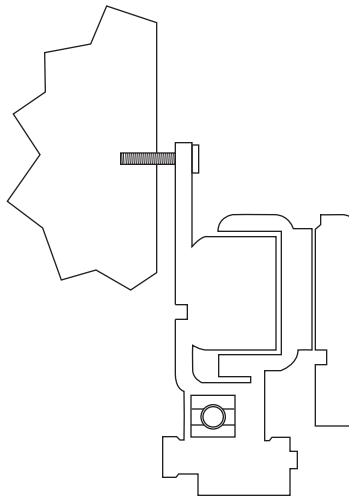

Figure 1
Rigid member

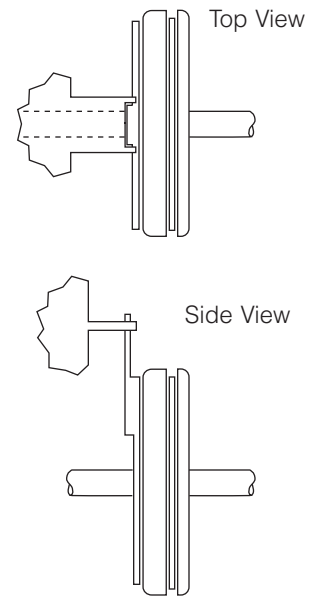

Figure 2
Rigid Member with Slot
Straddling Tab
(Preferred)

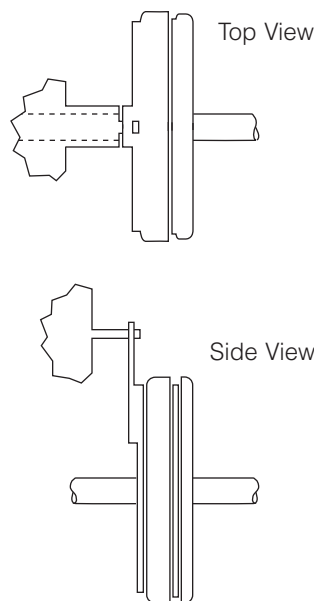

Figure 3
Pin in Hole
Loosely
(Preferred)

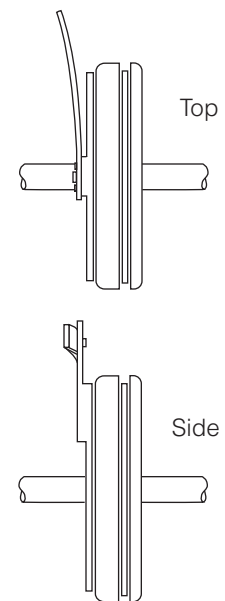

Figure 4
Flexible Strap
(Preferred)